



# BLUEPIRAT

BY MAGNA



## BLUEPIRAT Mini

### User Manual / 01.02.2022

Version 5.1.1

## Table of contents

<b>1</b>	<b>LICENSE AGREEMENT</b>	<b>5</b>
<b>2</b>	<b>PRODUCT LIABILITY</b>	<b>6</b>
2.1	Terms and Conditions of Sale and Delivery	6
2.2	Important operating instructions	6
<b>3</b>	<b>Overview</b>	<b>7</b>
<b>4</b>	<b>System requirements</b>	<b>8</b>
4.1	Further manuals	9
4.2	Additional features by optional licenses	10
4.3	Firmware Care	11
<b>5</b>	<b>The BLUEPIRAT Mini system</b>	<b>12</b>
5.1	Accessories	13
<b>6</b>	<b>The BLUEPIRAT mini data logger</b>	<b>14</b>
6.1	Model versions of BLUEPIRAT Mini	14
6.2	Front side	15
6.3	Rear side	15
<b>7</b>	<b>Controls and ports</b>	<b>16</b>
7.1	ON / Trigger button	16
7.2	LEDs	16
7.2.1	ACTIVE-LED (green)	16
7.2.2	STATE-LED (red)	17
7.3	ETH #1 / TSL and ETH #2 / TSL	17
7.4	Micro-USB port	17
7.4.1	USB storage:	18
7.5	SD card slot	19
7.5.1	Recommended SD cards	19
7.6	ETH #3 and ETH #4	20
7.7	Multifunction connector 44-pol SUB-D HD	20
7.8	Multifunction connector 15-pol SUB-D	21
7.9	MOST150 interface	21
7.10	MOST150 cPhy interface (Simplex or Duplex)	21
<b>8</b>	<b>Starting the BLUEPIRAT Mini</b>	<b>22</b>
8.1	Download and installation of the System Client	23
8.2	System Client portable	24
8.3	Default network settings	25
8.3.1	Resetting the network settings	25
8.4	Terminal IP address	26
8.5	Resetting the logger to factory settings	27
<b>9</b>	<b>Logging data</b>	<b>28</b>
9.1	Setting markers	28
9.1.1	Setting marker with an extern push button	28
9.2	Time stamp	29
9.3	Standby mode	30
<b>10</b>	<b>Interfaces</b>	<b>31</b>

10.1	CAN .....	31
10.1.1	CAN data with 29 Bit identifiers .....	31
10.1.2	Operating modes High Speed / Low Speed / CAN FD.....	31
10.1.3	Recording content .....	32
10.1.4	Sending CAN messages .....	32
10.1.5	LS-CAN and using a RC / RCV .....	32
10.2	LIN 33	
10.2.1	LIN data blocks and time stamps.....	33
10.2.2	LIN transceiver .....	33
10.2.3	Special frames and states .....	33
10.3	Serial (RS232) .....	34
10.3.1	Segmentation of the serial data .....	34
10.3.2	RS232 transceiver.....	34
10.4	FlexRay.....	34
10.5	Analog / Digital Input.....	35
10.6	Digital Output .....	35
10.7	Ethernet / Broad-R-Reach®.....	35
10.7.1	Supported Ethernet / Broad-R-Reach® protocols.....	35
10.7.1.1	GNLogger .....	35
10.7.1.2	UTF8.....	35
10.7.1.3	Raw.....	36
10.7.1.4	UDPServer .....	36
10.7.1.5	TCPServer .....	36
10.7.1.6	SpyMode.....	36
10.7.1.7	EsoTrace.....	36
10.7.1.8	Camera (license required) .....	37
10.7.1.9	DLT .....	37
10.8	MOST150 .....	37
10.9	ECL.....	38
<b>11</b>	<b>Conversion of recorded traces .....</b>	<b>39</b>
11.1	Conversion format overview .....	39
<b>12</b>	<b>Service and safety instructions .....</b>	<b>40</b>
<b>13</b>	<b>Data sheet .....</b>	<b>42</b>
13.1	Data sheet – BLUEPIRAT 8 CAN / 4 CAN-FD / 8 LIN / 20 LIN.....	42
13.2	Data sheet – BLUEPIRAT MOST150 / MOST150 cPhy / FlexRay .....	45
<b>14</b>	<b>Adapter cables &amp; pinning.....</b>	<b>48</b>
14.1	BLUEPIRAT Mini 8 CAN   44-pol SUB-D cable set .....	48
14.1.1	BLUEPIRAT Mini 8 CAN   44-pol SUB-D - Plug.....	48
14.1.2	BLUEPIRAT Mini 8 CAN   44-pol SUB-D - Pin assignment .....	49
14.1.3	BLUEPIRAT Mini 8 CAN   BroadR-Reach - Plug.....	50
14.2	BLUEPIRAT Mini 4 CAN-FD   44-pol SUB-D cable set.....	51
14.2.1	BLUEPIRAT Mini 4 CAN-FD   44-pol SUB-D - Pin assignment.....	52
14.3	BLUEPIRAT Mini 8 LIN   44-pol SUB-D cable set .....	53
14.3.1.1	BLUEPIRAT Mini 8 LIN   44-pol SUB-D - Pin assignment .....	54
14.4	BLUEPIRAT Mini 20 LIN   44-pol SUB-D cable set .....	55
14.4.1	BLUEPIRAT Mini 20 LIN   44-pol SUB-D - Pin assignment .....	56
14.6	BLUEPIRAT Mini FlexRay   44-pol SUB-D cable set.....	57

14.6.1	BLUEPIRAT Mini FlexRay   44-pol SUB-D - Pin assignment.....	58
14.8	BLUEPIRAT Mini MOST / cPhy   15-pol SUB-D – cable set.....	59
14.8.1	BLUEPIRAT Mini MOST / cPhy   15-pol SUB-D – Plug .....	59
14.8.2	BLUEPIRAT Mini MOST / cPhy   15-pol SUB-D - Pin assignment.....	60
14.8.3	MOST25 / 150 Connector (optical).....	60
14.8.4	MOST150 cPhy Connector (electrical) .....	60
14.9	Note for serial measurements.....	62
14.10	RJ45 Ethernet connector.....	62
14.11	Adapter cable for Remote Control Voice (RCV) .....	63
<b>15</b>	<b>Support.....</b>	<b>64</b>
15.1	Service Center .....	64
15.2	OTRS Ticket system.....	64
15.2.1	What is OTRS? .....	65
15.2.2	Needed information in a ticket .....	65
15.2.2.1	Ticket   Checklist.....	65
15.2.2.2	The points in detail .....	66
15.2.3	Sending Inquiries .....	67
15.2.4	Login and Initial Steps.....	67
15.2.5	Adding Files .....	67
15.2.6	Search Function.....	68
15.2.7	Closing a ticket.....	68
15.2.8	Contact.....	68
15.3	Sending in defective devices .....	69
15.3.1	Service report.....	69
15.3.2	Shipping address .....	69
15.3.3	Batteries:.....	69
<b>16</b>	<b>Abbreviations.....</b>	<b>70</b>
<b>17</b>	<b>List of figures.....</b>	<b>72</b>
<b>18</b>	<b>List of tables .....</b>	<b>73</b>
<b>19</b>	<b>Contact .....</b>	<b>74</b>

# 1 LICENSE AGREEMENT

Please read the license agreement of this license contract carefully, before you install the software. By the installation of the software you agree to the conditions of this license contract.

This software-license agreement, in the following called "license", contains all rights and restrictions for final users that regulate the use of the accompanying software, operating instructions and other documents, in the following called as "software".

1. This license contract is an agreement between licensor and licensee, who is being licensed to use the named software.
2. Licensee acknowledges that this is only a limited nonexclusive license. This means, that the licensee has no right to allocate sublicenses. Licensor is and remains the owner of all titles, rights and interests in the software.
3. The software is a copyright property of the MAGNA Telemotive GmbH. The program or parts of it may not be further licensed to third parts, rented, sold or be further marketed in any form without explicit written approval by MAGNA Telemotive GmbH. The user may neither change the software and their components, nor modify, nor redevelop or decompile otherwise in any form.
4. This software is subject to no warranty. This software is sold as is, without any warranty. If at any time, a user changes his system, we hold no responsibility to change our software to make it work again.
5. This license permits licensee to install the software on more than one computer system, as long as the software will not be used on more than one computer system simultaneously. Licensee will not make copies of the software or allow copies of the software to be made by others, unless authorized by this license agreement. Licensee may make copies of the software for backup purposes only. Licensee is not entitled to transmit or to transfer the software or its rights from this license agreement.
6. Licensor is not liable to licensee for any damages, including compensatory, special, incidental, exemplary, punitive or consequential damages, connected with or resulting from this license agreement or licensee's use of this software.
7. Licensee agrees to defend and indemnify licensor and hold licensor harmless from all claims, losses, damages, complaints or expenses connected with or resulting from licensee's business operations.
8. Licensor has the right to terminate this license agreement and licensee's right to use this software upon any material breach by licensee. The duration of the license contract is indefinitely determined.
9. Licensee agrees to return all copies of the software to licensor or to destroy them upon termination of the license contract.
10. This license agreement replaces and supersedes all prior negotiations, dealings and agreements between licensor and licensee regarding this software.
11. This license contract is subject to German law.
12. If a regulation of this license contract is void by law, the validity of the remaining regulations is not affected. If there is such a regulation it will be replaced by a valid, according to the legal regulations and enforceable regulation with similar intention and similar economic consequence.
13. The license contract is effective by delivery of the software of the licensor to the licensee and/or by usage of the software by the licensee. This license contract is also valid without licensor's signature.
14. The license automatically goes out if the licensee does not agree to the license regulations described here or offend against the license regulations of this license contract. With ending the license contract the licensee is obliged to extinguish or to destroy the software and all copies of it no matter if installed or stored on disk or to hand all of it back to MAGNA Telemotive GmbH.
15. The licensee is liable for all damages caused to the licensor by the violation of these license regulations.

## 2 PRODUCT LIABILITY

### 2.1 Terms and Conditions of Sale and Delivery

The General Terms and Conditions of Sale and Delivery of MAGNA Telemotive GmbH can be found on our website (<https://telemotive.magna.com>) under imprint.

### 2.2 Important operating instructions

**Please note these important instructions about the handling of devices of MAGNA Telemotive GmbH!**

There's a linux system running on the devices and sometimes when the device has a dirty shutdown due to a power break down or unplugging the power supply, the system is corrupt from this time. You know this situation from a PC, when you switch it off some times it maybe will not work any more or show you some mistakes.

In most cases this issue is catched up and repaired by the linux system we use, but sometimes it can happen that the system on the logger is damaged and there's no access to the device any more.

We are optimizing the handling of corrupted systems permanently and are integrating some new enhancements regarding this kind of issues with every new release to save the system. But we can't make the system for 100% save against these influences.

**So please use always the provided mechanism for shutting down the device or the implemented standby function in which the device shutting down when no traffic is detected any more in an adjustable time.**

### 3 Overview

This user guide describes the administration of the smallest generation of BLUEPIRAT data logger of MAGNA Telemotive GmbH, called **BLUEPIRAT Mini**.

This user guide describes hardware and interfaces as well as the general functions of the **BLUEPIRAT Mini**. The configuration and converting of the logged trace data is described in the user guide of the **System Client**.

This document refers to **firmware version 05.01.01** and the **System Client** from **version 5.1.1**. Some features depending on model and feature license or may not be available in older versions.

Software updates and user guides for other, optional, licensed enhancements are available in the Telemotive Service Center. (Please find the address under Contact at the last page.)

To ensure the most reliable operation of your system as possible, please make sure to use always current firmware and software versions.

[Index](#)

## 4 System requirements

The communication between bus systems and control units is monitored, and relevant data can be recorded very precisely with the data logger. The collected data are stored to the logger and can be downloaded via Ethernet to a PC.

### Control Unit

You need a Windows based Laptop or PC to configure the devices by the **System Client**. It also allows to save the recorded data and to use them offline later.

### System Client

Update, configure and read out your data loggers with System Client. Save time with central administration of your software products. System Client is your key to success for using all our products!

### BLUEPIRAT Rapid

High-performance multi-bus data logger for modern vehicle architectures based on Automotive Ethernet. With up to 3 TB internal memory and supreme recording performance. Robust and compact for in-vehicle use.

Due to the increasing complexity of driver assistance systems and the growing number of infotainment applications, the data traffic between ECUs in the most recent vehicle models has grown significantly. Consequently, besides the various classic bus systems, modern vehicle architectures are based on Automotive Ethernet according to BroadR-Reach / IEEE 802.3 100(0)Base-T1, which can keep up with the growing bandwidth demand.

### BLUEPIRAT Mini

The **BLUEPIRAT Mini** is smallest data logger in the world with an outstanding functional scope. It offers a wide range of interfaces, stable temperature behavior, very low energy consumption, four GBit Ethernet ports, and much more. Different blue PiraT Mini can be expanded flexibly to one cluster, and therefore handled very easily by using [System Link](#).

### BLUEPIRAT2

The **BLUEPIRAT2** is our top-class all-in-one data logger. Seven models cover a wide range of interfaces. (Device is EOL)

### BLUEPIRAT2 5E

Additionally, the **BLUEPIRAT2 5E** offers improved power management and power backup, five integrated Ethernet ports and super-fast start-up behavior. The BLUEPIRAT2 can be expanded flexibly via [System Link](#). (Device is EOL)

### Remote Control Touch (optional)

Operate your BLUEPIRAT data loggers safely and comfortably from the driver's or passenger seat. Via System Link our new remote control becomes part of your logger network. One remote control can handle all connected loggers.

### License

For some additional features an installed license is required. Settings for licensed features can be performed with a valid license only.

If you need a license for your logger, please contact our sales department (please find the address under contact at the last page).



## 4.1 Further manuals

Beside this user Manual, we offer the main manuals for our System Client as well as for the different data logger generations in our Service Center at

<https://sc.telemotive.de/bluepirat>.

Our licensed enhancements have own manuals which are stored in the Service Center too. You will find a list of these enhancements in the user manuals in the chapter **Additional features by optional licenses**.

Under the following links, you always will find the latest versions:

### User manual for the System Client

[https://sc.telemotive.de/4/uploads/media/SystemClient\\_UserManual.pdf](https://sc.telemotive.de/4/uploads/media/SystemClient_UserManual.pdf)

### User manual for BLUEPIRAT Rapid

[https://sc.telemotive.de/4/uploads/media/BLUEPIRAT\\_Rapid\\_UserManual.pdf](https://sc.telemotive.de/4/uploads/media/BLUEPIRAT_Rapid_UserManual.pdf)

### User manual for BLUEPIRAT Mini

[https://sc.telemotive.de/4/uploads/media/BLUEPIRAT\\_Mini\\_UserManual.pdf](https://sc.telemotive.de/4/uploads/media/BLUEPIRAT_Mini_UserManual.pdf)

### User manual for Remote Control Touch

[https://sc.telemotive.de/4/uploads/media/RCTouch\\_UserGuide.pdf](https://sc.telemotive.de/4/uploads/media/RCTouch_UserGuide.pdf)

### User manual for BLUEPIRAT Power Backup

[https://sc.telemotive.de/4/uploads/media/BLUEPIRAT\\_Power\\_Backup\\_UserManual.pdf](https://sc.telemotive.de/4/uploads/media/BLUEPIRAT_Power_Backup_UserManual.pdf)

### User manual for BLUEPIRAT2 / BLUEPIRAT2 5E

[https://sc.telemotive.de/4/uploads/media/BLUEPIRAT2\\_UserManual.pdf](https://sc.telemotive.de/4/uploads/media/BLUEPIRAT2_UserManual.pdf)

### User manual for BLUEPIRAT Remote

[https://sc.telemotive.de/4/uploads/media/BLUEPIRAT\\_Remote\\_UserGuide.pdf](https://sc.telemotive.de/4/uploads/media/BLUEPIRAT_Remote_UserGuide.pdf)

For having an easy access if necessary, the most important manuals are linked in the client under the menu item [Help] and are reachable easily from there.

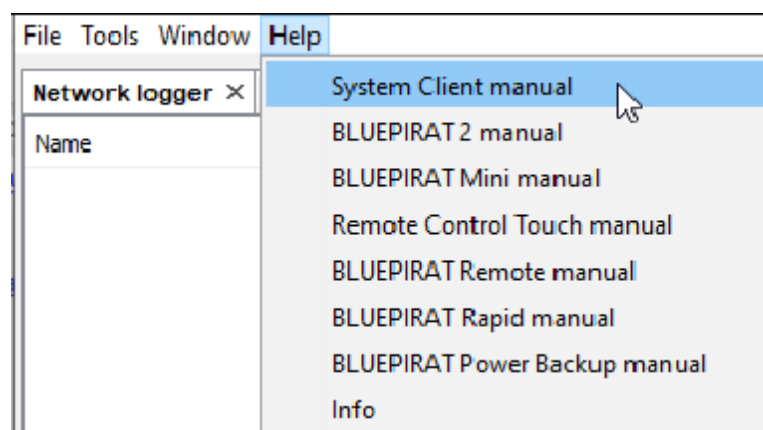

Figure 4.1: links to the manuals in the System Client

## 4.2 Additional features by optional licenses

Additional features can be activated by purchasing and installing licenses. Licenses can be ordered at our sales team. You find the user guides for these additional features in our Service Center. Currently the following licensed features are available.

Feature	Description
<b>Camera Link</b>	video recording via video server or network cameras Till now, only some cameras from AXIS were supported
<b>WLAN</b>	supporting wireless LAN / WiFi (802.11, 802.11a, 802.11n), (802.11ac from FW 02.04.01)
<b>GPS logging</b>	tracking of GPS data
<b>Measurements with CCP</b>	CAN Calibration Protocol
<b>Measurements with XCP</b>	Universal Measurement and Calibration Protocol Currently the functionality for Ethernet (XCP on Ethernet) and the CAN-bus (XCP on CAN) are available.
<b>MOST150 Streaming</b>	logging MOST150 synchronous/isochronous data
<b>MLBevo / QXDM</b>	The license Connected-Gateway MLBevo enables the recording of data of the ATOP control unit MLBevo via USB to the Magna Telemotive data logger and convert these data with the System Client. (from FW 02.03.01) Additional this license allows to log Qualcomm QXDM logs via USB (from FW 03.06.XX)
<b>Download Terminal</b>	The in the System Client integrated Download Terminal allows an automatization of configured tasks for a defined group of devices. (from FW 02.03.01)
<b>Test automation</b>	Interface for connecting to test automation tools. At the moment, the sending of CAN messages is supported. (from FW 02.04.01)
<b>Cellular network</b>	Allows the logger to send status messages over cellular network. (from FW 03.01.01)
<b>Firmware Care</b>	As part of the " Service Product Firmware Care ", new software and firmware versions are made available for download for a limited period of time. This service is available for 12 months from the date of purchasing the <b>BLUEPIRAT</b> .  This period can be extended by licenses.

Table 4.1: Additional features by optional licenses

## 4.3 Firmware Care

MAGNA Telemotive GmbH invests a great amount in the further development of its products.

For this we regularly provide new functions and enhancements via firmware and client releases.

### Basic conditions

As part of the " Service Product Firmware Care ", new software and firmware versions are made available for download for a limited period of time. This service is available for 12 months from the date of purchasing the **BLUEPIRAT**. This period can be extended.

For details, please contact your sales partner (see contact at the end of the manual for addresses).

### Affected products

- **BLUEPIRAT Rapid**
- **BLUEPIRAT Mini**
- **Remote Control Touch**
- **BLUEPIRAT2 5E**
- **BLUEPIRAT2**
- **BLUEPIRAT Remote**

### Note:

Enhancements are only possible in current firmware releases.

### Attention:

**Please note that updates to main firmware versions (05.00.01 / 06.00.01) need a special update license and can't be flashed to a device without this license.**

To buy these licenses please contact our sales department under [TMO.Sales@magna.com](mailto:TMO.Sales@magna.com) (please find the complete address under *Contact on the last page*).

## 5 The BLUEPIRAT Mini system

The **BLUEPIRAT Mini** is a data logger, which offers the following interfaces, depending on the model:

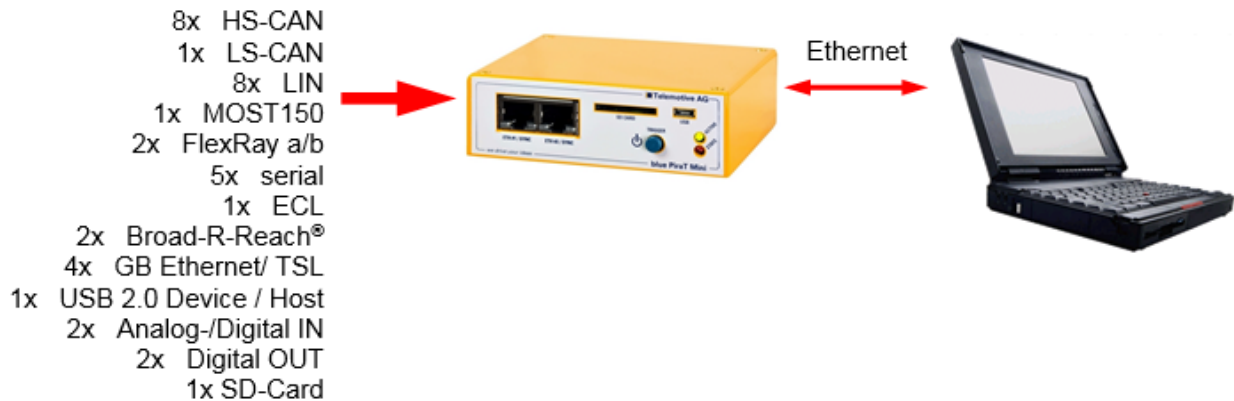

**Figure 5.1: Interface (overview)**

The data logger can be mounted in a vehicle and due to his large storage capacity of the hard drive of currently approx. 50 GB usable space, the **BLUEPIRAT Mini** is able to support extensive test runs. After the data has been gathered it has to be downloaded via Ethernet. For the download and the conversion of the logging data the System Client is available.

For the available conversion options to various trace file formats please have a look at chapter **Conversion format overview**. The BLUEPIRAT Mini is available with different features (see chapter Additional features by optional licenses)

The BLUEPIRAT Mini is designed to create minimum interference with the vehicle's bus systems and interfaces. The data logger listens to the data traffic without operating as a bus node.

Additionally to the data recording functionality, the BLUEPIRAT Mini provides online data processing functions:

- simple CAN and MOST filters
- custom-defined messages can trigger the setting of markers

## 5.1 Accessories

There are various accessories available for the **BLUEPIRAT Mini** data logger:

- various adapter cables
- the Remote Control Touch and BLUEPIRAT Remote as remote control with touch-pad and recording option for voice notes
- licenses which enhance the functionality of the BLUEPIRAT Mini
- mounting bracket

Please contact our sales department for more information about these accessories.

Manuals are available from our Service Center.

## 6 The BLUEPIRAT mini data logger

### 6.1 Model versions of BLUEPIRAT Mini

The BLUEPIRAT Mini is manufactured in various model versions to offer a wide range of connectivity in relation to the available interfaces. So an optimal utilization is ensured, depending on the existing bus systems.

The table below shows, which busses will be supported from the different models of BLUEPIRAT Mini. Please consider that the using of Broad-R-Reach or TSL reduces the quantity of available Gbit Ethernet interfaces.

blue PiraT Mini Model							
Interface	8 CAN (out of production)	4 CAN-FD (via CAN-FD)	8 LIN (out of production)	20 LIN	MOST150	MOST150 cPhy	FlexRay
CAN-HS	8	4	2	-	2	2	4
CAN-FD	-	4	-	-	-	-	-
CAN-HS / CAN-LS switchable	-	-	-	-	1 <sup>*1</sup>	1 <sup>*1</sup>	-
CAN-LS	1 <sup>*2</sup>	1 <sup>*2</sup>	1 <sup>*2</sup>	-	1 <sup>*1</sup>	1 <sup>*1</sup>	1 <sup>*2</sup>
LIN	2	-	8	20	-	-	2
Gbit Ethernet	4	4	4	-	4	4	4
Broad-R-Reach	2	2	-	-	-	-	-
MOST 150	-	-	-	-	1	-	-
MOST 150 cPhy Simplex or Duplex	-	-	-	-	-	1	-
FlexRay	-	-	-	-	-	-	2
USB 2.0 Host	1	1	1	-	1	1	1
Analog IN / Digital IN	2+1 <sup>*4</sup>	2+1 <sup>*4</sup>	2+1 <sup>*4</sup>	-	2+1 <sup>*4</sup>	2+1 <sup>*4</sup>	2+1 <sup>*4</sup>
Digital OUT	2	2	2	-	-	-	2
Seriell RS232	5	5	5	-	3(4) <sup>*3</sup>	3(4) <sup>*3</sup>	5
Ethernet / TSL	2	2	2	2	2	2	2
ECL (Electronic control line)	-	-	-	-	1	1	-
*1 One CAN-HS can be switched to CAN-LS and then used as port for the RCV							
*2 One CAN-HS can be configured as CAN-LS							
*3 One RS232 will be used for ECL (Electronic Control Line) if required							
*4 Three channels, whereas the first only measures the input voltage of the logger							

**Table 6.1: Versions of the BLUEPIRAT Mini data logger**

## 6.2 Front side

The **BLUEPIRAT Mini** has two 1-Gbit-Ethernet-ports at the front side (**ETH #1 / TSL** und **ETH #2 / TSL**).

On the front side there are also the **[ON / Trigger]** button as well as LEDs for **ACTIVE** and **STATE**, a **Micro-USB**-connector and the receptacle for **SD cards**.



Figure 6.1: Front panel of the BLUEPIRAT Mini

## 6.3 Rear side

On the rear side are two more 1-Gbit-Ethernet ports (**ETH #3** and **ETH #4**) and the **44-pol SUB-D HD** multifunctional main connector for power supply and some of the **[Interfaces]**.



Figure 6.2: Rear side of the BLUEPIRAT Mini 8 CAN / 4 CAN-FD / 8 LIN / FlexRay / 20 LIN

On the rear side of **BLUEPIRAT Mini MOST** the multifunctional main connector for power supply and some of the interfaces are realized with a **15-pol SUB-D** connector. Additionally you'll find at the MOST logger a **MOST150** or **MOST150 cPhy** connector.



Figure 6.3: Rear side of the BLUEPIRAT Mini MOST150 / MOST150 cPhy (Simplex / Duplex)

## 7 Controls and ports

This chapter describes the usage of the controls and ports on the front and rear side of the BLUEPIRAT Mini.

### 7.1 ON / Trigger button

The **[ON / Trigger]** button on the front panel is used for these actions:

Function	Device status	Handling
<b>Start device</b>	out of action	Push the <b>[ON / Trigger]</b> button.
<b>Wake up device</b>	in standby mode	Push the <b>[ON / Trigger]</b> button.
<b>Set Marker</b>	in operational state	Push the <b>[ON / Trigger]</b> button.
<b>Shut down device (to standby mode)</b>	in operational state	Push and hold the <b>[ON / Trigger]</b> button. (about 3 to 5 seconds)
<b>Reset network settings back to default settings</b>	in standby mode	Start the device. Push and hold the <b>[ON / Trigger]</b> button, until the STATE-LED flashes red twice. (~ 15 seconds) Shut down device and start it again, to set the settings.

Table 7.1: Overview of the functions of the **[ON / Trigger]** button

**Note:** The **[ON / Trigger]** button has set a debouncing time of 335 ms.

### 7.2 LEDs

The **BLUEPIRAT Mini** has two LEDs **ACTIVE** and **STATE** on his front side. They can have the following states.

#### 7.2.1 ACTIVE-LED (green)

State	Meaning
<b>Off</b>	Device is off or in standby mode.
<b>On</b>	Device has started up and can be reached by the client.
<b>Blinking</b>	Device is starting up.
<b>Pulsing</b>	Device goes to standby mode.

Table 7.2: **ACTIVE-LED**

Maybe these states are overlain by a fast blinking when there is traffic on one of the active interfaces (accept protocol based Ethernet logging).

If an internal or external marker is set, the **ACTIVE-LED** flashes with full energy for a short time.



## 7.2.2 STATE-LED (red)

State	Meaning
Off	No error, normal operational status
On	Device is in error state. If the device is still reachable by the client, the error and some hints to solve this issue can be found in the bug reporter.
blinking	Overload of the data logger; maybe loss of data Information about lost data can be found in the bug reporter.
blinking	When using external storage: The external storage is identified.
pulsing	Disk space to 95% full and ring buffer deactivated

Table 7.3: STATE-LED

## 7.3 ETH #1 / TSL and ETH #2 / TSL

The network ports at the front side, ETH #1 / TSL and ETH #2 / TSL, are for the communication between logger and client as well as for logging data.

Further they can be used to combine BLUEPIRAT Mini and BLUEPIRAT2 data logger to a combined TSL (System Link) and synchronize these loggers.

**Warning: Don't connect ETH #1 and ETH #2 directly to each other.**

[Index](#)

## 7.4 Micro-USB port

The front Micro-USB port can be used in host-mode.

It can be used for logging data to an external storage or for connecting a GPS, mobile phone or Wi-Fi module to the logger. Wi-Fi can be used to get access to the logger over the client or to use the feature **Live View**.

From firmware version 03.04.01, Telemotive data loggers also support logging data from units which communicate over **Android LogCat interface** via USB.

### 7.4.1 USB storage:

#### Requirements:

Size	At least 4 GB (or a partition at least with this size)
Free memory	At least 3 GB for the circular buffer (only for parallel recording)
File system	FAT32, NTFS or ext4
USB	Version 2.0 (partly USB 3.0 memory is also supported)

You could connect USB flash drives and external hard drive up to a maximal supply current of 500 mA. External power supplies must not be connected to the hard disk.

If the USB memory is pulled in the operational state, the following problems exists:

- The logger is in an undefined state and will not record any data. Only after rebooting the device behaves as expected.
- The data on the USB memory can then be unreadable when it is removed during a write operation.

If you turn off the BLUEPIRAT Mini with the **[ON / Trigger]** button, you have 5 seconds to remove the medium before the logger can be reawakened.

#### Note:

**MAGNA Telemotive GmbH recommends the testing of every external storage before using it in a measurement. We suggest that especially USB devices with USB 3.0 are sometimes not recognized by the system.**

## 7.5 SD card slot

The **BLUEPIRAT Mini** offers the possibility to store data parallel to a removable media as SD card or USB device. The configuration of this feature is described in the System Client user guide.

### Requirements:

Size	At least 4 GB (or a partition at least with this size)
Free memory	At least 3 GB for the circular buffer (only for parallel recording)
File system	FAT32, NTFS or ext4
Write protection	unlocked

### 7.5.1 Recommended SD cards

The following SD cards have been tested with the BLUEPIRAT Mini and released for use:

Manufacturer	Description	Size	Type
SanDisk	Extreme PRO SDXC UHS-I Card	512 GB	SDXC
SanDisk	Extreme PRO	64 GB	SDXC
Transcend	Ultimate Speed	64 GB	SDHC
Transcend	Ultimate Speed	32 GB	SDHC
Transcend	Ultimate Speed	16 GB	SDXC
Kingston	SD10VG2	32 GB	SDHC
Kingston	SDA3	16 GB	SDHC
Intenso	3431490 Professional	64 GB	SDXC
Intenso	3431470	32 GB	SDHC
Hama	Class 10 45 Mbps	64 GB	SDXC
Hama	Class 10 45 Mbps	16 GB	SDHC
Extrememory	HyPerformance Class 10	32 GB	SDHC
Extrememory	Performance Class 6	16 GB	SDHC
SanDisk	Extreme	32 GB	SDHC

Table 7.4: Compatible SD cards

#### Attention:

The format of cards over 32 GB with FAT32 must be done via a Linux system, since Windows only supports the formatting of FAT32 up to 32 GByte.

Removing the SD card without prior shutdown may result in the loss of all recorded data.

If the removable media is detected by the logger, the red State LED starts flashing.

A write-protected SD memory card will be indicated by the permanent illumination of the red STATE LED.

In addition, the write protection will be highlighted in the network logger window of the System Client with a red labelled exclamation mark and an entry in the bug report "FC\_MS\_READ\_ONLY" with a corresponding note.

Then shut down the bP Mini, unlock the SD card, reinsert it and reboot the device.

If the SD card is pulled in the operational state, the following problems exist:

- The logger is in an undefined state and will not record any data. Only after rebooting the device behaves as expected.
- The data on the SD card can then be unreadable when the SD card is removed during a write operation.

If you turn off the BLUEPIRAT Mini with the **[ON / Trigger]** button, you have 5 seconds to remove the disk before the logger can be reawakened.

## 7.6 ETH #3 and ETH #4

The network ports at the rear side, **ETH #3** and **ETH #4**, are for logging data.

**Warning:** Don't connect **ETH #3** and **ETH #4** directly to each other.

## 7.7 Multifunction connector 44-pol SUB-D HD

At **BLUEPIRAT Mini 8 CAN / 4 CAN-FD / 8 LIN / 20 LIN / FlexRay** this connector has these functions, depending on the logger model:

- |                                  |                  |
|----------------------------------|------------------|
| • Power supply                   | KL 30 and KL 31  |
| • Clamp 15                       | KL 15            |
| • High Speed CAN                 | HS-CAN           |
| • Low Speed CAN / Remote Control | LS-CAN           |
| • CAN-FD                         | CAN-FD           |
| • LIN                            | LIN              |
| • FlexRay                        | FR x Ch A / Ch B |
| • Serial                         | RS232            |
| • Analog-Digital IN              | ANA IN / ANA COM |
| • Digital OUT                    | DIG OUT          |
| • Broad-R-Reach®                 | BRR              |

### Notice:

**The logger is protected against reverse polarity of the power supply. But devices which are connected to the logger can be damaged when the logger is connected in the wrong way.**

## 7.8 Multifunction connector 15-pol SUB-D

At BLUEPIRAT Mini MOST this connector has these functions:

- |                                  |                  |
|----------------------------------|------------------|
| • Power supply                   | KL 30 and KL 31  |
| • High Speed CAN                 | HS-CAN           |
| • Low Speed CAN / Remote Control | LS-CAN           |
| • Serial                         | RS232            |
| • Analog-Digital IN              | ANA IN / ANA COM |
| • Digital OUT                    | DIG OUT          |

## 7.9 MOST150 interface

The MOST150 interface is a standard 2 + 0 connector for MOST fiber optic.

**Important:**

**Maybe the MOST150 connector can't be plugged when the 15-pol SUB-D connector is not locked.**

**If the MOST connector is not used, the jack must be covered with a terminating plug. This prevents the sensitive fiber optic contacts from getting dirty. It also makes sure that the data logger does not start up unintentionally when, e.g., strong sunlight falls onto the optical contacts.**

## 7.10 MOST150 cPhy interface (Simplex or Duplex)

The MOST150 cPhy connector is the newer version of MOST150 with electrical instead of optical data transfer.

## 8 Starting the BLUEPIRAT Mini

Connect the **BLUEPIRAT Mini** to the vehicle battery or a power supply via the power harness (**red/Vbat+/clamp 30** and **black/GND-/clamp 31**).

Connect the Gigabit-Ethernet-port **ETH #1 / TSL** with the Ethernet port of your computer by using a Ethernet cable. (**Note: By default the BLUEPIRAT Mini is configured as \*Automatic DHCP-configuration for TSL with IP 192.168.0.233\*.**)

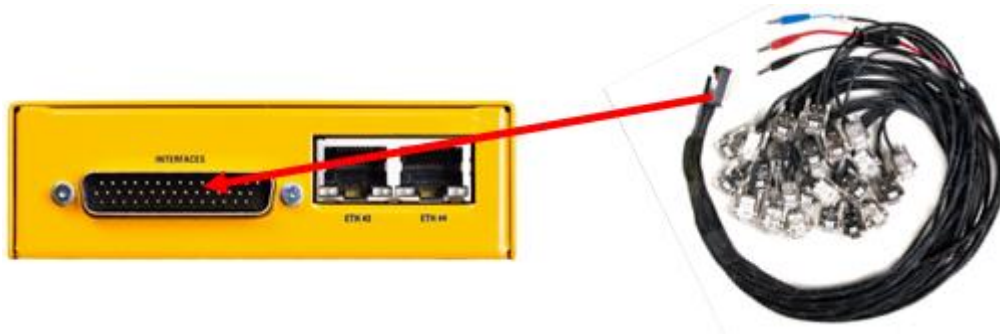

**Figure 8.1: Power connection**

When the power supply is switched on, the logger will start automatically when you plug in the power supply.

Is the BLUEPIRAT Mini in standby mode please press the **[ON / Trigger]** button to start the device.

To switch off the BLUEPIRAT Mini please press the **[ON / Trigger]** button for about 5 seconds till the green ACTIVE-LED starts pulsing.

The boot sequence takes about 15 seconds, until the logger is reachable by the System Client. Data logging is starting much earlier.

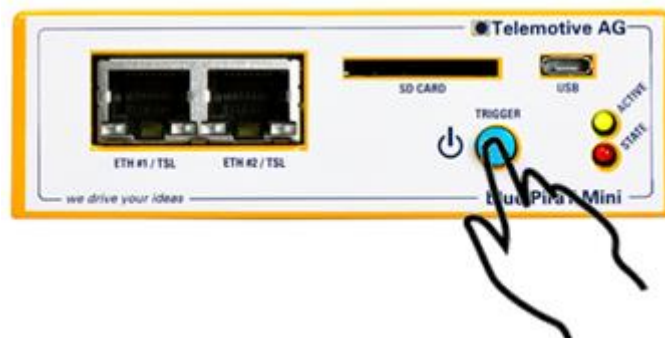

**Figure 8.2: Switching on the BLUEPIRAT Mini**

## 8.1 Download and installation of the System Client

Open your internet browser and enter the IP address of the logger

(Default settings: **Automatic DHCP configuration for TSL with IP 192.168.0.233**) and press **[Enter]**.

<http://192.168.0.233/client.html>

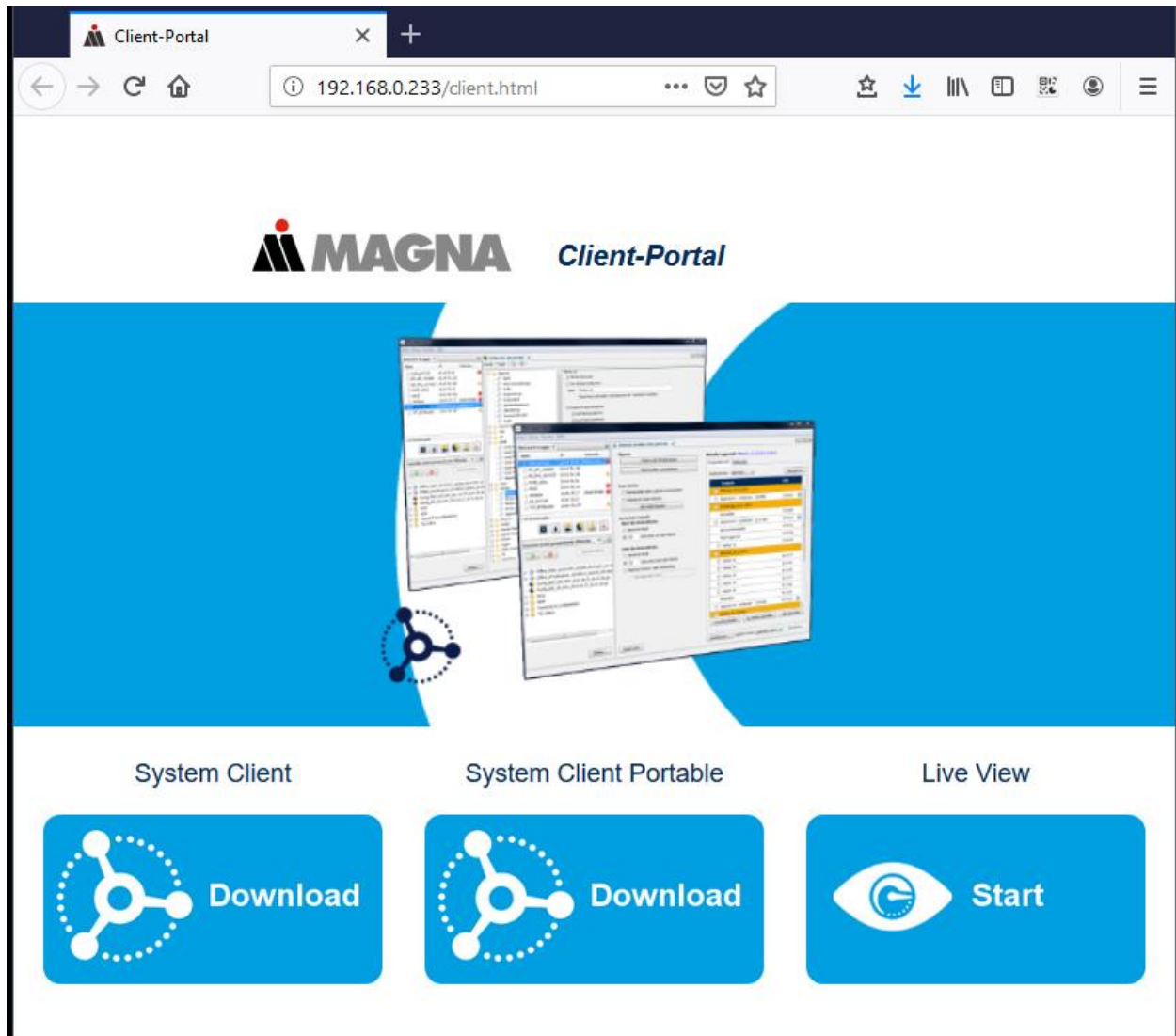

**Figure 8.3: Client Portal**

The connection between the logger and your computer system will be established. Please take care that the network settings of your network adapter are set to **Obtain IP address automatically**.

Click **[Download]**, to download the System Client (64 Bit) as portable or install version directly from the logger. The 32 Bit version is available in our service center.

The links are the same as these ones:

**System Client:** [https://sc.telemotive.de/4/uploads/media/System\\_Client\\_Setup.zip](https://sc.telemotive.de/4/uploads/media/System_Client_Setup.zip)

**System Client portable:** [https://sc.telemotive.de/4/uploads/media/System\\_Client\\_Portable.zip](https://sc.telemotive.de/4/uploads/media/System_Client_Portable.zip)

Follow these steps, depending on your browser:

Browser	Proceeding
Internet Explorer	Click <b>[Save]</b> , to locally save the file on your system. Click <b>[Accomplish]</b> .
Mozilla Firefox	Click <b>[Save file]</b> , to locally save the file on your system. Click the arrow on the right top of the browser menu and select the downloaded application in the appearing context menu.

In the dialog that opens select the desired software language from the dropdown menu.  
Click **[OK]**.

Follow the instructions in the next dialog and select an installation directory.  
Click **[Install]**.

After successful installation you will find the **System Client** icon on your desktop. Double-click the icon to start the application.

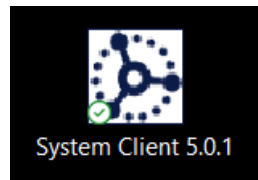

Figure 8.4: Desktop icon

## 8.2 System Client portable

The System Client is also available as a portable version which needs no installation but unpacking. This version is ready for downloading in our Service Center.

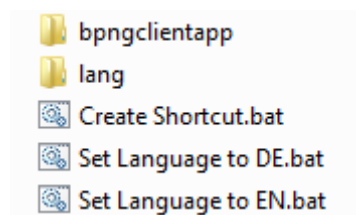

Figure 8.5: Content of the portable client

The portable version includes some batch files for these functions:

<b>Create Shortcut.bat</b>	creates a shortcut for the start file of the portable client
<b>Set Language to DE.bat</b>	changes the language into german
<b>Set Language to EN.bat</b>	changes the language into english (standard)



## 8.3 Default network settings

### Important:

The loggers default setting is \*Automatic DHCP-configuration for TSL with IP 192.168.0.233\*) and has to be connected by an Ethernet cable from „ETH #1 / TSL“ or „ETH #2 / TSL” to your computer system. You can download the System Client by typing this IP address into your web browser:

⇒ <http://192.168.0.233>

### 8.3.1 Resetting the network settings

If you have no access to the logger any more please follow the instructions of chapter 7.1 ON / Trigger button **to reset the network settings**.

<b>Reset network settings back to default settings</b>	in standby mode	Start the device. Push and hold the <b>[ON / Trigger]</b> button, until the STATE-LED flashes red twice. (~ 15 seconds) Shut down device and start it again, to set the settings.
--	-----------------	--

## 8.4 Terminal IP address

Each **BLUEPIRAT** has an additional, permanently set network address internally, which can be used to reach the device if the set IP address cannot be reached. This address can also be used if several devices have the same IP setting. For this feature every data logger has a second, fixed IP address in the subnet 10.1.X.Y which can be contacted by the System Client.

Each terminal IP address is unique!

These additional IP addresses are all located in subnet 10.1.X.Y. The system client can access the devices via this IP address

### Attention:

**To use this option your computers network port has to be set to the fixed IP address 10.1.255.254 and subnet mask 255.255.0.0.**

To set this IP address, please go to the specific network connection at **[Properties]** change the IP settings and close the window with **[OK]**.

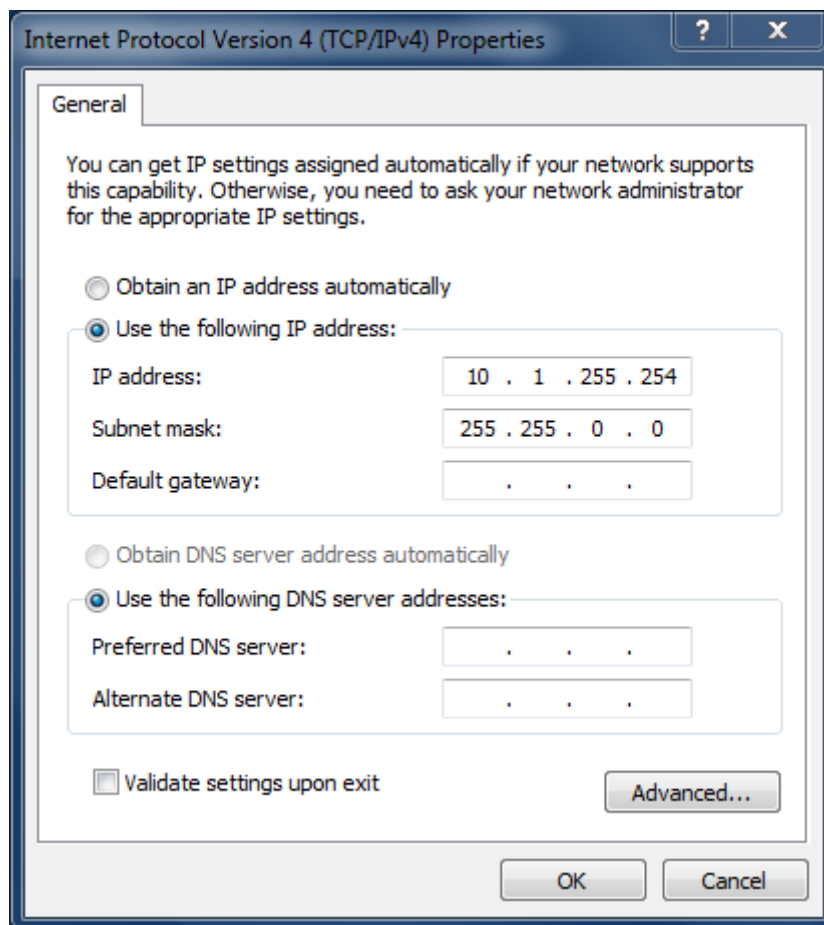

**Figure 8.6: Change IP settings**

If this is given, the system client finds the devices on the alternative IP address and displays them in the network logger list with the terminal IP address. From then on the devices can be used as usual. This allows the loggers to be read out simultaneously without having to operate them as a DHCP client or change the IP settings on each logger.

## 8.5 Resetting the logger to factory settings

Beside the possibility to reset the network settings, the BLUEPIRAT Mini offers the possibility to reset the device to factory respectively delivery status, if the logger is in error state and there's no chance to connect to the logger any more (even after a network reset).

### **Warning:**

**Due to the reset to factory settings all data and licenses on the logger will be deleted.**

**Needed licenses have to be installed on the logger again after this operation.**

**An actual firmware version has to be flashed after this procedure. This is signaled by the STATE-LED and a failure message "FC\_FW\_UPDATE" at the client.**

To reset the logger to factory settings the logger has to be unplugged from power supply.

While you connect the logger with the power supply again, press the **[ON / Trigger]** button, until both LEDs are pulsing.

### **Note:**

**If you do nothing, the logger tries to startup normally, in case of the button was pressed by mistake during plug in.**

During the short phase, in which the LEDs are pulsing (for about 10 seconds), quickly press many times the **[ON / Trigger]** button, until both LEDs are blinking alternately.

The device starts to reset itself to factory settings. This operation will take some minutes. The BLUEPIRAT Mini will switch off after this procedure automatically.

## 9 Logging data

### 9.1 Setting markers

Interesting occurrences can be marked by the **[ON / Trigger]** button at the front panel or at the Remote Control / Remote Control Voice by setting a timestamp. When you are pressing this button, the data logger saves the current time to the internal storage as a marker.

It is possible to configure the data logger to send a CAN message as an acknowledgement of setting a marker

Additionally **complex triggers** are making it possible to define a message that triggers a marker. In all cases, marker triggers are debounced.

When downloading the data, the client displays all markers in a data overview. In this data overview, the client can be configured to transfer the data close to selected markers.

#### 9.1.1 Setting marker with an extern push button

It is also possible to use the digital inputs and **complex triggers** function to realize an external marker button. Important is to set the used interface active and in the <General settings> of this interface the **[Timing Mode]** is enabled and the <Sampling interval> is set to 100 ms or more.

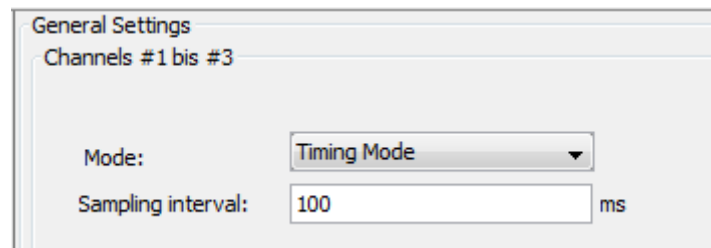

Figure 9.1: General settings

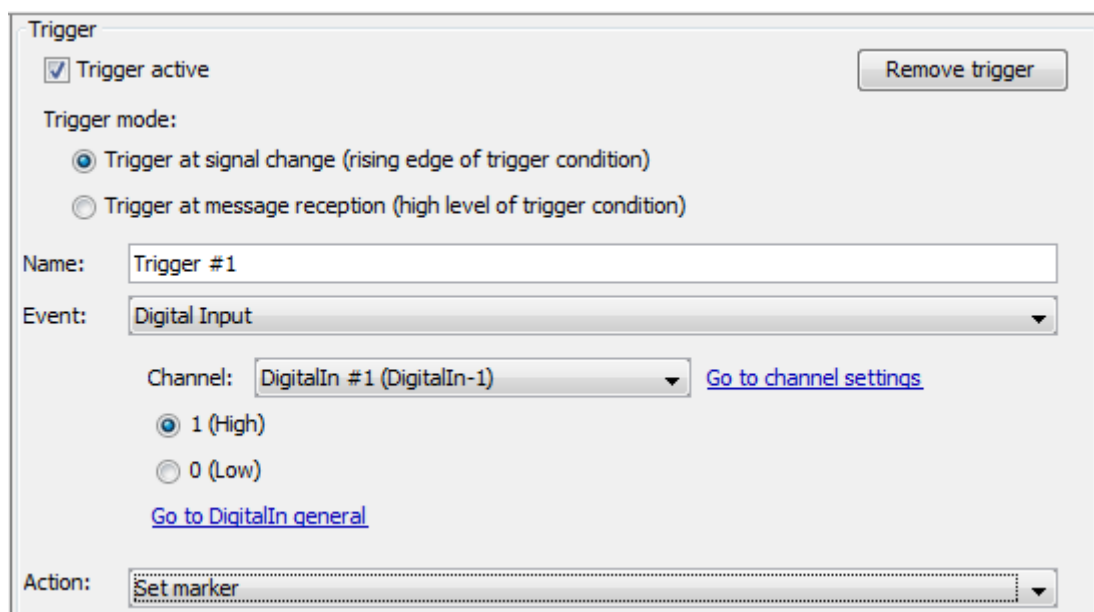

Figure 9.2: Setting Trigger with Digital Input

The setting for the <Sampling interval> is needed to debounce the external push button and to be sure that only one trigger is set. The external push button can be connected to the power supply of the car and the Digital In mentioned above.

**Note:**

**Digital IN and Analog IN are combined to one wire at BLUEPIRAT Mini. Please connect the ground for Analog IN when you use an external push button.**

## 9.2 Time stamp

Usually the recorded messages will get a time stamp at the end of each received message. The time stamp is included on most interfaces at the end of the message. Only for the serial interface (RS232) the start of the transfer will be used as timestamp.

Trace Data	Accuracy	Start	End
MOST25	1 $\mu$ s		x
MOST150	1 $\mu$ s		x
ECL	1 $\mu$ s		x
CAN	1 $\mu$ s		x
LIN	1 $\mu$ s		x
FlexRay	1 $\mu$ s		x
Ethernet	100 ms		x
RS232	1 ms	x	

**Table 9.1: Accuracy of marker**

### 9.3 Standby mode

The table below shows, which busses or signals are monitored for keeping the logger alive and which busses or signals are able to wake up the logger.

Schnittstelle / Interface	Wachhalten / Keep alive	Aufwecken / Wake up	Konfigurierbar / configurable W = wake up A = keep alive	Kommentar / comment
MOST150	✓	✓	W / A: Ein / Aus W / A: On / OFF	Licht an / light on
ECL	✓	✓	W / A: Ein / Aus W / A: On / OFF	
High Speed CAN	✓	✓	W / A: Ein / Aus W / A: On / OFF	
Low Speed CAN	✓	✓	W / A: Ein / Aus W / A: On / OFF	
LIN	✓	✓	W / A: Ein / Aus W / A: On / OFF	
FlexRay	✓	✓	W: FlexRay 1a-2b	
Seriell RS232	✓	✓	W / A: Ein / Aus W / A: On / OFF	
Ethernet 1 Gbit	✓	-	A: Ein / Aus A: On / OFF Alive time	Zeit / time: General / Standby
Analog In	-	-	-	
Digital In 1 - 3	-	-	-	
USB	-	-	-	
Remote Control	-	✓	-	via [ON / Trigger] -Taste/ via [ON / Trigger] -button
[ON / Trigger] -Taste [ON / Trigger] -button	-	✓	-	
WLAN	-	-	-	
KL 15	✓	✓	W / A: Ein / Aus W / A: On / OFF	

**Table 9.2: Standby mode**

## 10 Interfaces

The different interfaces of the BLUEPIRAT Mini supported bus systems are described in this chapter in more detail.

### 10.1 CAN

The BLUEPIRAT Mini is able to record data in compliance with the CAN specification 2.0a (11 Bit identifier) and 2.0b (29 Bit identifier).

#### 10.1.1 CAN data with 29 Bit identifiers

The BLUEPIRAT Mini can also log CAN data with 29 Bit identifiers. You don't have to configure anything. All the CAN data will be logged as they are available on the CAN bus. It is also possible to log CAN messages mixed with **CAN specification 2.0a (11 Bit)** and **CAN specification 2.0b (29 Bit)** identifiers.

#### 10.1.2 Operating modes High Speed / Low Speed / CAN FD

Depending on the model, the BLUEPIRAT Mini has different numbers of High Speed (HS), Low Speed (LS) CAN or CAN FD interfaces. It is not possible to change a CAN interface. Each type is using different transceivers.

The electrical behavior of the Low Speed and the High Speed CAN is different, hence, the Low Speed CAN port of the BLUEPIRAT Mini must not be connected to a High Speed CAN bus and vice versa.

Both operating modes use differential signals (CANH, CANL). For the correct data recording, all nodes of the bus must have a common reference potential. The BLUEPIRAT Mini uses the connection "**clamp 31**" as a reference potential. The lines of the High Speed CANs are terminated with a high resistance.

	Low Speed CAN	High Speed CAN	CAN FD
<b>Transceiver chip</b>	Philips NXP 1055	Philips NXP TJA1041	NXP TJA1044GT
<b>Terminating resistor</b>	4k64	10k	4k64
<b>Baud rate – data channel</b>	50 kbit/s - 125 kbit/s	50 kbit/s - 1 Mbit/s	50kbit/s – 5Mbit/s
<b>Baud rate – control channel</b>	-	-	50kbit/s – 1Mbit/s
<b>Supported identifiers (SW)</b>	11 and 29 Bit	11 and 29 Bit	11 and 29 Bit
<b>Disabling acknowledge</b>	possible	possible	possible
<b>Time stamps</b>	at the end of the telegram	at the end of the telegram	at the end of the telegram

**Table 10.1: CAN**

### 10.1.3 Recording content

The BLUEPIRAT Mini is able to record the following error states of the CAN bus:

- Stuff error
- Format error
- Acknowledge error
- Bit 0/1 error
- CRC error
- Overrun

These error states are only included in the Telemotive file formats. After reaching a certain number of errors (50 errors), the recording of error states is interrupted until reception of the next successful CAN message to avoid an overload of the recorded data.

### 10.1.4 Sending CAN messages

If the BLUEPIRAT Mini sends a CAN message, it is shown twice in the trace: The first message indicates the transmit request of the data logger and the second message indicates the actual transmission of the message.

In the CANoe file format these messages are indicated as “TxRq” and “Tx”, respectively. The transmit request messages are not included in file format that don't support them.

### 10.1.5 LS-CAN and using a RC / RCV

The Low Speed CAN (LS-CAN) as well can be used for connecting a Remote Control / Remote Control Voice.

If you use a RC / RCV the logger will trace no data on LS-CAN. This will be shown in the System Client as a warning.

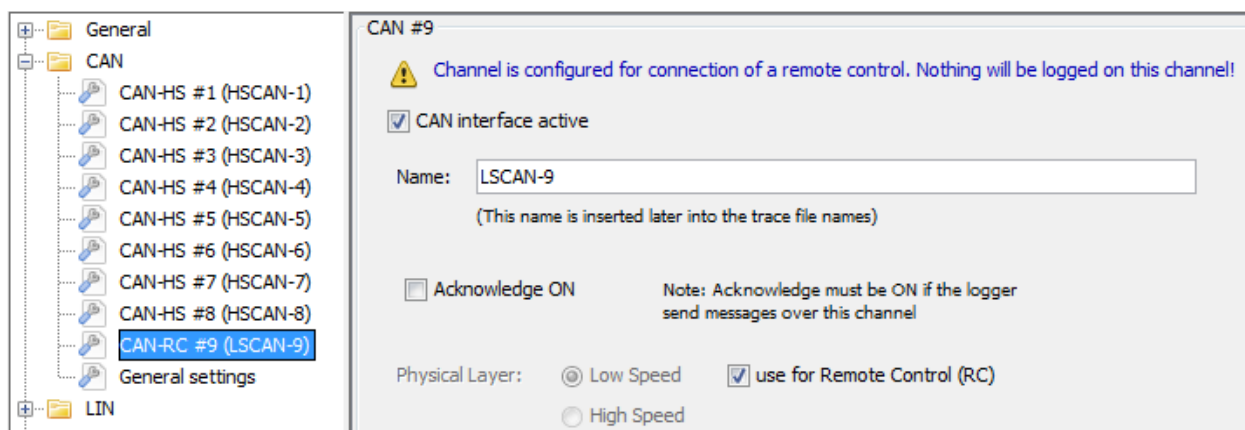

Figure 10.1: Notification message due to use of LS-CAN channel for Remote Control



## 10.2 LIN

The BLUEPIRAT Mini is able to record data compliant to the LIN specification V1.3, V2.0 and V2.1. The data logger does not actively appear as a bus member. Sending LIN messages isn't supported currently.

<b>Channels</b>	up to 20
<b>Transmission Rate</b>	1200, 2400, 4800, 9600, 19200, 20000 Baud
<b>Transmitter</b>	TJA1021
<b>Status</b>	Parity BITS, format Check for Header, Checksum for Header and Payload
<b>Terminating resistor</b>	30 kOhm

Table 10.2: LIN

### 10.2.1 LIN data blocks and time stamps

Each LIN message receives a time stamp, which marks the end of the message. If the data logger receives LIN data without a valid header, it creates blocks containing the erroneous data. The maximum block size is 10 bytes. A block is also concluded after a timeout, which is three times the transmission time of a LIN character.

### 10.2.2 LIN transceiver

The BLUEPIRAT Mini uses the LIN transceiver TJA1021 by NXP (former Philips Semiconductor). Supported baud rates are in the range from 1200 to 20000 Baud. Automatic baud rate detection is currently not supported. The LIN interface is configured as a slave device with a terminating resistor of 30 kΩ.

### 10.2.3 Special frames and states

Additionally to the normal frame data, the following information is recorded:

- Wake-Up Frames
- Checksum Errors

## 10.3 Serial (RS232)

<b>Channels</b>	up to 5
<b>Data bits</b>	5, 6, 7, 8
<b>Stop bits</b>	1, 2, 1.5
<b>Parity</b>	None, odd, even

**Table 10.3: Serial interface**

The BLUEPIRAT Mini supports only the RS232 specification.

### 10.3.1 Segmentation of the serial data

The received serial data are clustered into data blocks separately for each channel. Each block is finalized after a certain time or when it reaches a certain maximum size. The time is 30 to 60 ms depending on the channel. The maximum size is 49 to 80 bytes. A time stamp is assigned to each block when it is finalized.

### 10.3.2 RS232 transceiver

The threshold voltages for data reception are the usual RS232-defined values. A logical "1" is recognized for input voltages smaller 0 Volts, a logical "0" for input voltages higher than 3 Volts.

## 10.4 FlexRay

The BLUEPIRAT Mini is able to record FlexRay bus data according to the FlexRay specification 2.1A. The data logger records all valid and invalid, static and dynamic frames of the two FlexRay channels, including "a" and "b", independently if the FlexRay bus is in a synchronous or asynchronous state.

<b>Channels</b>	2x (a + b)
<b>Max. bit rate</b>	10 Mbit/s
<b>Frames</b>	Static, Dynamic, Null Sync, Startup
<b>Transceiver</b>	AS8221

**Table 10.4: FlexRay**

#### Attention:

**For every measurement with FlexRay the line must be separated and lead through the BLUEPIRAT Mini. Therefore all connectors exist two times at the cable set.**

**Turning off the BLUEPIRAT Mini thereby causes no interruption of the FlexRay line.**

## 10.5 Analog / Digital Input

The BLUEPIRAT Mini has three analog and three digital inputs, whereas respectively the first channel is located in the logger and records the input voltage. The measuring range is between 0 V and + 20 V, the accuracy is 3 %. The sampling rate is adjustable from 1 ms to 100 s. The switching threshold for the digital input is  $7\text{ V} \pm 0.2\text{ V}$ , see chapter 13 Data sheet.

The interfaces are combined in the cable set but can be used both at one time.

The combined ground has to be connected always!

## 10.6 Digital Output

The BLUEPIRAT Mini models CAN, FlexRay and LIN have two digital outputs. The output current is up to 1 A per channel.

## 10.7 Ethernet / Broad-R-Reach®

All versions of the BLUEPIRAT Mini data logger are able to log Ethernet data. All data loggers have two 1 Gbit Ethernet ports with RJ45 connector on the front and two more at the rear side.

The two interfaces **ETH #1 / TSL** and **ETH #2 / TSL** can be used to connect the data logger to the PC and for the TSL (System Link) connection.

**Broad-R-Reach** is an Ethernet based standard, which allows multiple components of the electrical system of a vehicle to get access to information by using unshielded twisted pair wires simultaneously.

The **BLUEPIRAT Mini CAN & 4 CAN-FD** allows to disable the rear Ethernet ports **ETH #3** and **ETH #4** and activate the connectors **BRR 1** and **BRR 2** at the harness to be used for **BroadR-Reach**.

### 10.7.1 Supported Ethernet / Broad-R-Reach® protocols

This section gives an overview of the available protocols. When a protocol requires a license, this will be marked.

#### 10.7.1.1 GNLogger

For connecting a standard TCP (open socket connection) is used. Therefore the BLUEPIRAT Mini is a TCP slave device.

GNLogger is a proprietary serial protocol used for some ECU diagnosis.

#### 10.7.1.2 UTF8

The BLUEPIRAT Mini will initiate a TCP connection to a TCP server by using an open socket connection (you can configure IP/Port of server via client software).

By using UTF8 data transmission the logger will write a timestamp after every detected Linefeed (LF) from the incoming data.

If the connection is getting lost, it will take about 5 seconds to build up a new connection for logging data again.

### 10.7.1.3 Raw

When using the raw data transmission over TCP the BLUEPIRAT Mini will be a TCP slave device. Therefore the BLUEPIRAT Mini will initiate a TCP connection to a TCP server by using an open socket connection (you can configure IP/Port of server via client software).

When using raw data transmission, every data package up to 40 Kbytes is getting a time stamp and will be written on the logger.

If the connection is getting lost, it will take about 5 seconds to build up a new connection for logging data again.

### 10.7.1.4 UDPServer

The BLUEPIRAT Mini can be configured as a UDP server by setting up an IP address and port number.

There is an adjustable timeout. The connection will be terminated if no data arrives. This appears as a message in the trace file. There is no configurable debug level. The BLUEPIRAT Mini as a UDP server accepts UDP data packets, UDP multicast and UDP broadcast packets.

If the connection is getting lost, it will take about 5 seconds to build up a new connection for logging data again.

### 10.7.1.5 TCPServer

The BLUEPIRAT Mini can be configured as a TCP server by setting up an IP address and port number.

There is an adjustable timeout. The connection will be terminated if no data arrives. This appears as a message in the trace file. There is no configurable debug level. The BLUEPIRAT Mini as a TCP server accepts TCP data packets, TCP multicast and TCP broadcast packets.

If the connection is getting lost, it will take about 5 seconds to build up a new connection for logging data again.

### 10.7.1.6 SpyMode

By using the Ethernet Spy mode it is possible to log all Ethernet data (promiscuous mode).

More information can be found in the **System Client User Guide**.

### 10.7.1.7 EsoTrace

By using the EsoTrace mode it is possible to log data in the EsoTrace protocol.

More information can be found in the **System Client User Guide**.

### 10.7.1.8 Camera (license required)

If you use a camera license on the data logger, it is possible to connect up to four Ethernet webcams to the BLUEPIRAT Mini. After connecting the BLUEPIRAT Mini is able to log MPEG4 video streams.

More information can be found in the **Camera User Guide**.

### 10.7.1.9 DLT

If you use DLT on the data logger, it is possible to connect up to 16 ECU for logging their DLT messages.

## 10.8 MOST150

The **BLUEPIRAT Mini MOST150** data logger is able to log messages from the MOST150 bus of the following types.

<b>Status</b>	MPR (Maximum Position Register), MDC (MOST Data Channel), Light on, System Lock Flag, Shut Down Flag, Ring Lock Flag, Open Ring/Multi Master Flag, Node Position Changes of the states are only logged when the state is changing.
<b>Control</b>	Control Messages
<b>Streaming</b> <sup>*1</sup>	Synchronous and isochronous data
<b>Packet</b>	MDP (MOST Data Packet), MEP (MOST Ethernet Packet)
<b>Filter</b>	Control Messages on/off, Packet on/off, MDP on/off, MEP on/off, Status on/off, MDP Transmit and Receive Address, Packet Length, MEP Receive Address, Message Length
	<sup>*1</sup> requires a separate license <b>MOST150 Streaming</b>

**Table 10.5: MOST150 data logging**

The SMSC SpyNIC MOST150 is used to provide the MOST150 traffic data.

The data logger is not an active part of the bus system because it is working in a spy mode. The device is able to log messages immediately after wake up.

Before the logging data are saved on the internal memory, they are buffered in a ring buffer. In the case of a data rate peak, which exceeds the storage rate of the internal memory, storage of data is still possible.

If the MOST150 data rate is permanent higher than the maximum storage rate, the data logger will stepwise deactivate channels: first the MEP and MDP channel, then the control channel and at last the status messages.

To ensure logging of maximum continuous data blocks a hysteresis is implemented. Before logging MEP and MDP messages again, the ring buffer data has to be fully stored on the hard disk. Before starting the logging of the MEP and MDP messages again the system sends a "Lost Message". This message contains information about how many messages of which type were rejected.

## 10.9 ECL

Currently the ECL (Electrical Control Line) is only supported in conjunction with MOST150. In general, the ECL is a slow LIN bus. The following ECL messages will be recorded:

- EWU (Electrical Wake-Up)
- STWU (System Test Wake-Up)
- STP (System Test Parameters)
- STR (System Test Results)
- Undefined Pulse

[Index](#)

# 11 Conversion of recorded traces

All trace data will be recorded internally in the proprietary Telemotive TMT format (\*.tmt). If the recorded trace data will be downloaded and sorted, the data will be converted to an Extended TMT format (\*.xtmt).

The client provides the possibility to convert the internal format in other formats, to make the data readable or to prepare them for available analyzing tools.

More information about the file formats and a detailed manual for conversion can be found at the **System Client User Guide**.

## 11.1 Conversion format overview

The table below shows which data of the interfaces can be converted to other formats.

		Format / format																				Ver. 2021-01														
		*.txt	*.txt	*.dlc	*.blf	*_CANCORDER.asc	*.asc	*.esotrace	*.raw	*.xtmt	*.xjaa	*.gpx	*.kml	*.kmz	*.log	*.mdf	*.mdf	*.mf4	*.mf4	*.img	*.mpeg4	*.ts	*.nmea	*.op2	*.qmdl	*.RAW.txt	*.txt	*.pcap	*.txt	*.pcap	*.TC.trc	*_WUL.txt	*.pcapng			
		APN ASCII	ASCII Hexadecimal	DLT Logging Format	Binary Logging Format	CANCorder	CANoe ASCII	Eso Trace file	Ethernet Raw	Extended Telemotive Trace File	GN-Log	GPS Exchange Format	KML Google Maps Format	KMZ comp. Google Maps Format	MDF Logging	MDF CAN Signal Format v3.3	MDF CCP XCP Signal Format v3.3	MDF Bus Logging Format v4.1	MDF Signal Logging Format v4.1	MOST Data Analyser Format	MPEG-4	MPEO Isochron raw file	NMEA - ASCII GPS Format	OptoLyzier Format	Qualcomm Memory Device Log File	RAW Serial	Serial Debug Format	Serial Trace Analyser Format	TCPDump	Telemotive ASCII Format	Trace Client Format	WakeUpLine ASCII Format	Wireshark PCAP NG			
Tracedaten / Trace data																																				
Analog IN																																				
CAN / CAN-FD																																				
CCP_XCP																																				
Digital IN																																				
WakeUpLine (Digital IN #1 & #2)																																				
ECL																																				
Ethernet																																				
- Ethernet - DLT																																				
- Ethernet - EsoTrace																																				
- Ethernet - GN Log																																				
- Ethernet - RAW																																				
- Ethernet - TCP Server																																				
- Ethernet - UDP Server																																				
- Ethernet - UTF8																																				
Ethernet - Spy / MI																																				
FlexRay																																				
GPS																																				
Kamera/Video																																				
LIN																																				
MOST150 (CTRL / MDP)																																				
MOST150 MEP																																				
MOST150 Stream																																				
MOST25 CTRL																																				
MOST25 MDP																																				
Serial RS232																																				
Signal based filter																																				
USB / Conn.-Gateway MLBevo																																				
<b>Marker</b>		<b>P</b>	<b>M</b>	<b>P</b>	<b>M</b>	<b>M</b>	<b>M</b>	<b>M</b>	<b>M</b>	<b>M</b>	<b>M</b>	<b>M</b>	<b>M</b>	<b>M</b>	<b>M</b>	<b>M</b>	<b>M</b>	<b>M</b>	<b>M</b>	<b>M</b>	<b>P</b>	<b>P</b>	<b>M</b>	<b>M</b>	<b>M</b>	<b>M</b>	<b>M</b>	<b>M</b>	<b>M</b>	<b>M</b>	<b>M</b>	<b>M</b>				
<b>Konvertierung / converting</b>		<b>1</b>	<b>1</b>	<b>m</b>	<b>m</b>	<b>m</b>	<b>m</b>	<b>1</b>	<b>1</b>	<b>1</b>	<b>1</b>	<b>1</b>	<b>1</b>	<b>1</b>	<b>1</b>	<b>m</b>	<b>m</b>	<b>1</b>	<b>1</b>	<b>1</b>	<b>1</b>	<b>1</b>	<b>1</b>	<b>1</b>	<b>1</b>	<b>1</b>	<b>1</b>	<b>1</b>	<b>1</b>	<b>1</b>	<b>1</b>	<b>1</b>				
<b>Marker</b>	<b>M</b>	Marker kann in Trace geschrieben werden																																		
	<b>P</b>	Marker kann nur als CAN / MOST Pseudonachrichten in die Datei geschrieben werden																																		
<b>Konvertierung / converting</b>	<b>m</b>	eine Datei für mehrere Kanäle																																		
	<b>1</b>	einzelne Datei pro Kanal																																		

Table 11.1: Conversion options (overview)

## 12 Service and safety instructions

### Note according to standard EN55011:2009

The device is used in an industrial environment. Due to occurring, grid-bound as well as radiated disturbances, it might possibly be difficult to ensure compliance with electromagnetic compatibility in other environments. The cable length shall not exceed 3 meters.

### Cleaning

The device may only be cleaned with a clean cloth slightly dampened with water. Other cleaning agents such as gasoline, alcohol, etc., may not be used.

### Maintenance

The device is maintenance-free. The case must not be opened by the customer. Unauthorized modifications will void the warranty.

### Fuse

In case of failure, the customer may change the fuse of the cable set or fuses accessible from outside only. The fuse may only be replaced with a fuse of the same type and nominal current rating.

### Disposal

Disposal of the unit, must be in accordance with the statutory laws and regulations.

### Instruction on installation

Assembly of the device shall only take place in all three specified axes.

### Operational temperature

Operation of the device shall only be performed within the temperature range specified in the data sheet (see chapter Data sheet).

All tests to determine the valid operational temperature are performed under laboratory conditions. In real operation deviating temperatures can occur. Internal cut-off mechanisms exist, that prevent impermissible heating of the device's components.

A sufficient ventilation is to be taken into consideration. The unit and other components shall not be stacked atop each other provided that there is no adequate cooling ensured and the device shall be used in ambient temperatures exceeding +25°C.

**During operation under unfavorable circumstances case temperatures that exceed +70°C can occur, as the metal case contributes directly for the passive cooling of the unit. At elevated ambient temperatures the case shall not be touched due to risk of injury. Operation of the device is only permissible in industrial premises with restricted access.**

### Storage conditions

The device may only be stored within a temperature range of - 40 °C to + 85 °C.

### Condensation

During condensation the unit must not be activated. For this purpose appropriate waiting periods must be taken into consideration.

### Environmental conditions

The unit must not be used in outdoor areas or unfavorable environmental conditions such as moisture, high air humidity or dust. Furthermore it is forbidden to operate the device in flammable or explosive atmospheres. The maximum power supply voltage must not exceed +30V. Overvoltage can destroy the device and voids the warranty.



**Cable sets**

When inserting the cable sets in the usual case, only a slight force is required. At an increased mechanical resistance during insertion of the cable set, the correct alignment of the pins should be checked.

Special cable sets are to be manufactured strictly according to the sheet of the instruction manual containing the pin assignment, whereby an extra fuse provided on the cable set must be considered. The connectors specified in the instruction manual should be used.

Two pairs of pins are assigned to only one type of electrical potential, that means an interconnection to positive electrical potential (Klemme 30/Clamp 30) for one related pair and the negative one (Klemme 31/Clamp 31) for the other matching pair.

**Warning:**

**A short circuit directly at the connector between clamb 30 and clamb 31 leads to the destruction of the device.**

The cable sets' temperature range is restricted to -20°C to +70°C due to the banana plugs.

**Mounting**

In laboratory setups and automobiles the units must be attached in such a way, that it is ensured against dropping, slipping and skidding.

**Positioning of the antenna**

While operating the device in an automobile, the connected antennas must not be located outside of the vehicle.

**Replacing the battery**

A lithium button cell is located within the device, which must be only replaced by MAGNA Telemotive GmbH.

**Mechanical exposure**

+++++ Environment during operation +++++  
Height: -300 to 5500 m

+++++ Environment out of service +++++  
Height -300 to 12000 m

## 13 Data sheet

### 13.1 Data sheet – BLUEPIRAT 8 CAN / 4 CAN-FD / 8 LIN / 20 LIN

General data	bPMini 8 CAN	bPMini 4 CAN-FD	bPMini 8 LIN	bPMini 20 LIN
Nominal power supply voltage	13.8 V	13.8 V	13.8 V	13,8 V
Power supply voltage	7 to 28 V at system start up 5 to 29,8 V when running divergence +/- 8%	7 to 28 V at system start up 5 to 29,8 V when running divergence +/- 8%	7 to 28 V at system start up 5 to 29,8 V when running divergence +/- 8%	7 to 28 V at system start up 5 to 29,8 V when running divergence +/- 8%
Reverse polarity protection of the supply voltage	Yes	Yes	Yes	Yes
Resistance to short-circuiting	Yes	Yes	Yes	Yes
Power consumption / operating (typ.)	300 mA (@ 13.8 V)	300 mA (@ 13.8 V)	300 mA (@ 13.8 V)	300 mA (@ 13.8 V)
Power consumption / operating (peak.)	5A	5A	5A	5A
Power consumption / standby	< 1 mA	< 1 mA	< 1 mA	< 1 mA
Operating temperature	- 40 °C to + 70 °C (+/-2°C)	- 40 °C to + 70 °C (+/-2°C)	- 40 °C to + 70 °C (+/-2°C)	- 40 °C to + 65 °C (+/-2°C)
Storage temperature	- 40 °C to + 85 °C	- 40 °C to + 85 °C	- 40 °C to + 85 °C	- 40 °C to + 85 °C
Weight (ca.)	250 g	250 g	250 g	250 g
<b>Power Management</b>	<b>bPMini 8 CAN</b>	<b>bPMini 4 CAN-FD</b>	<b>bPMini 8 LIN</b>	<b>bPMini 20 LIN</b>
Startup time from standby to full operation	ca. 25 s	ca. 25 s	ca. 25 s	ca. 25 s
Start of logging - starting from standby	CAN, LIN, Serial, Analog, Digital < 210 ms	CAN, LIN, Serial, Analog, Digital < 210 ms	CAN, LIN, Serial, Analog, Digital < 210 ms	LIN < 230 ms
Start of logging - Ethernet / BroadR-Reach, AutoNeg off	ca. 1,7s / 21s	ca. 1,7s / 21s	ca. 1,7s / 21s	---
Standby Mode	Configurable time without bus load	Configurable time without bus load	Configurable time without bus load	Configurable time without bus load
Wake	HS-CAN, LS-CAN, LIN, Serial, KL 15, [ON / Trigger] button	HS-CAN, LS-CAN, LIN, Serial, KL 15, [ON / Trigger] button	HS-CAN, LS-CAN, LIN, Serial, KL 15, [ON / Trigger] button	LIN [ON / Trigger] button
Data loss by power loss	If the device is switched off due to sudden power loss, up to 60 sec. of data may be lost.	If the device is switched off due to sudden power loss, up to 60 sec. of data may be lost.	If the device is switched off due to sudden power loss, up to 60 sec. of data may be lost.	If the device is switched off due to sudden power loss, up to 60 sec. of data may be lost.
<b>Case</b>	<b>bPMini 8 CAN</b>	<b>bPMini 4 CAN-FD</b>	<b>bPMini 8 LIN</b>	<b>bPMini 20 LIN</b>
Size (ca.)	4,13" x 3,35" x 1,30" (105 x 85 x 33 mm)	4,13" x 3,35" x 1,30" (105 x 85 x 33 mm)	4,13" x 3,35" x 1,30" (105 x 85 x 33 mm)	4,13" x 3,35" x 1,30" (105 x 85 x 33 mm)
Operating controls	Push-button to start and shut down data logger and to set markers	Push-button to start and shut down data logger and to set markers	Push-button to start and shut down data logger and to set markers	Push-button to start and shut down data logger and to set markers
LEDs (STATE, ACTIVE)	Yes	Yes	Yes	
<b>Connectors</b>	<b>bPMini 8 CAN</b>	<b>bPMini 4 CAN-FD</b>	<b>bPMini 8 LIN</b>	<b>bPMini 20 LIN</b>

<b>Front connectors</b>	2x Gbit Ethernet, SD card, Micro--USB 2.0	2x Gbit Ethernet, SD card, Micro--USB 2.0	2x Gbit Ethernet, SD card, Micro--USB 2.0	2x Gbit Ethernet
<b>Rear connectors</b>	2x Gbit ETH SUB-D 44-pol: Power supply, 8x HS-CAN, 1x LS-CAN, 2x LIN, 5x Serial, 2x Analog In, 2x Digital In, 2x Digital Out, 2x BroadR-Reach	2x Gbit ETH SUB-D 44-pol: Power supply, 4x CAN-FD or HS-CAN, 1x LS-CAN, 2x LIN, 5x Serial, 2x Analog In, 2x Digital In, 2x Digital Out, 2x BroadR-Reach	2x Gbit ETH SUB-D 44-pol: Power supply, 2x HS-CAN, 1x LS-CAN, 8x LIN, 5x Serial, 2x Analog In, 2x Digital In, 2x Digital Out	2x Gbit ETH SUB-D 44-pol: Power supply, 20x LIN
<b>Data recording</b>	<b>bPMini 8 CAN</b>	<b>bPMini 4 CAN-FD</b>	<b>bPMini 8 LIN</b>	<b>bPMini 20 LIN</b>
<b>Storage type (internal)</b>	58 GB flash	58 GB flash	58 GB flash	58 GB flash
<b>Storage type (external)</b>	USB flash drive SD card	USB flash drive SD card	USB flash drive SD card	---
<b>Recording modes</b>	Normal, ring buffer	Normal, ring buffer	Normal, ring buffer	Normal, ring buffer
<b>Timestamp accuracy</b>	1 µs	1 µs	1 µs	1 µs
<b>CAN recording</b>	<b>bPMini 8 CAN</b>	<b>bPMini 4 CAN-FD</b>	<b>bPMini 8 LIN</b>	<b>bPMini 20 LIN</b>
<b>Channel</b>	8 High Speed, 1 Low Speed	4 CAN-Flexible Data or High Speed, 1 Low Speed	2 High Speed, 1 Low Speed	---
<b>Baud rate</b>	Up to 1000000 Baud at HS-CAN up to 125000 Baud at LS-CAN	Up to 1000000 Baud at HS-CAN and 5000000 at CAN-FD up to 125000 Baud at LS-CAN	Up to 1000000 Baud at HS-CAN up to 125000 Baud at LS-CAN	---
<b>Transceiver</b>	TJA1041A, TJA1055T	TJA1041A, TJA1055T	TJA1041A, TJA1055T	---
<b>Filter</b>	CAN ID filter	CAN ID filter	CAN ID filter	---
<b>Status recording</b>	Error frames	Error frames	Error frames	
<b>Serial recording</b>	<b>bPMini 8 CAN</b>	<b>bPMini 4 CAN-FD</b>	<b>bPMini 8 LIN</b>	<b>bPMini 20 LIN</b>
<b>Type</b>	RS232	RS232	RS232	---
<b>Channel</b>	5	5	5	---
<b>Baud rate</b>	1200, 2400, 4800, 9600, 19200, 38400, 57600, 115200, 230400 Baud	1200, 2400, 4800, 9600, 19200, 38400, 57600, 115200, 230400 Baud	1200, 2400, 4800, 9600, 19200, 38400, 57600, 115200, 230400 Baud	---
<b>Data bits</b>	5,6,7,8	5,6,7,8	5,6,7,8	---
<b>Stop bits</b>	1,1.5,2	1,1.5,2	1,1.5,2	---
<b>Parity</b>	None, odd, even	None, odd, even	None, odd, even	---
<b>LIN recording</b>	<b>bPMini 8 CAN</b>	<b>bPMini 4 CAN-FD</b>	<b>bPMini 8 LIN</b>	<b>bPMini 20 LIN</b>
<b>Channel</b>	2	2	8	20
<b>Baud rate</b>	1200, 2400, 4800, 9600, 10400, 19200, 20000 Baud	1200, 2400, 4800, 9600, 10400, 19200, 20000 Baud	1200, 2400, 4800, 9600, 10400, 19200, 20000 Baud	1200, 2400, 4800, 9600, 10400, 19200, 20000 Baud
<b>Transceiver</b>	TJA1021	TJA1021	TJA1021	TJA1022
<b>Ethernet recording</b>	<b>bPMini 8 CAN</b>	<b>bPMini 4 CAN-FD</b>	<b>bPMini 8 LIN</b>	<b>bPMini 20 LIN</b>
<b>Port</b>	4	4	4	---
<b>Speed</b>	2x 1 Gbit/s (front side) 2x 100 Mbit/s (rear side, Protocol logging / 1 Gbit/s SPY-Mode)	2x 1 Gbit/s (front side) 2x 100 Mbit/s (rear side, Protocol logging / 1 Gbit/s SPY-Mode)	2x 1 Gbit/s (front side) 2x 100 Mbit/s (rear side, Protocol logging / 1 Gbit/s SPY-Mode)	---
<b>Recording</b>	GNLog, Raw, UTF8, UDP, DLT (optional), EsoTrace (optional)	GNLog, Raw, UTF8, UDP, DLT (optional), EsoTrace (optional)	GNLog, Raw, UTF8, UDP, DLT (optional), EsoTrace (optional)	---
<b>BroadR-Reach recording</b>	2 Ports, Master/Slave changeable	2 Ports, Master/Slave changeable		

<b>BroadR-Reach Phy</b>	Broadcom BCM54810	Broadcom BCM54810		
<b>Analog recording</b>	<b>bPMini 8 CAN</b>	<b>bPMini 4 CAN-FD</b>	<b>bPMini 8 LIN</b>	<b>bPMini 20 LIN</b>
<b>Channel</b>	1x Ubat (internal), 2x external	1x Ubat (internal), 2x external	1x Ubat (internal), 2x external	---
<b>Range of measurement</b>	Channel 1: 0V to +30V Channel 2/3: 0V to +20V	Channel 1: 0V to +30V Channel 2/3: 0V to +20V	Channel 1: 0V to +30V Channel 2/3: 0V to +20V	---
<b>Resolution</b>	8 mV	8 mV	8 mV	---
<b>Accuracy</b>	3 % 0 -16V 4 % 16 – 20 / 32V	3 % 0 -16V 4 % 16 – 20 / 32V	3 % 0 -16V 4 % 16 – 20 / 32V	---
<b>Sampling interval</b>	1 ms to 100 s	1 ms to 100 s	1 ms to 100 s	---
<b>Digital input</b>	<b>bPMini 8 CAN</b>	<b>bPMini 4 CAN-FD</b>	<b>bPMini 8 LIN</b>	<b>bPMini 20 LIN</b>
<b>Channel</b>	2 (physically identical with analog input)	2 (physically identical with analog input)	2 (physically identical with analog input)	---
<b>Switching threshold</b>	7 V ± 0.2 V	7 V ± 0.2 V	7 V ± 0.2 V	---
<b>Sampling interval</b>	1 ms to 100 s	1 ms to 100 s	1 ms to 100 s	---
<b>Digital output</b>	<b>bPMini 8 CAN</b>	<b>bPMini 4 CAN-FD</b>	<b>bPMini 8 LIN</b>	<b>bPMini 20 LIN</b>
<b>Channel</b>	2	2	2	---
<b>Output voltage</b>	~ Ubat	~ Ubat	~ Ubat	---
<b>Output current</b>	Up to 1.0 A (continuous load)	Up to 1.0 A (continuous load)	Up to 1.0 A (continuous load)	---

Table 13.1: Datasheet - BLUEPIRAT Mini 8 CAN / 4 CAN-FD / 8 LIN / 20 LIN

[Index](#)

## 13.2 Data sheet – BLUEPIRAT MOST150 / MOST150 cPhy / FlexRay

General data	bPMini MOST150	bPMini MOST150 cPhy	bPMini FlexRay
<b>Nominal power supply voltage</b>	13.8 V	13.8 V	13.8 V
<b>Power supply voltage</b>	7 to 28 V at system start up 5 to 29,8 V when running divergence +/- 8%	7 to 28 V at system start up 5 to 29,8 V when running divergence +/- 8%	7 to 28 V at system start up 5 to 29,8 V when running divergence +/- 8%
<b>Reverse polarity protection of the supply voltage</b>	Yes	Yes	Yes
<b>Resistance to short-circuiting</b>	Yes	Yes	Yes
<b>Power consumption / operating (typ.)</b>	300 mA (@ 13.8 V)	300 mA (@ 13.8 V)	300 mA (@ 13.8 V)
<b>Power consumption / operating (peak.)</b>	5A	5A	5A
<b>Power consumption / standby</b>	< 1 mA	< 1 mA	< 1 mA
<b>Operating temperature</b>	- 40 °C to + 70 °C (+/-2°C)	- 40 °C to + 60 °C (+/-2°C)	- 40 °C to + 70 °C (+/-2°C)
<b>Storage temperature</b>	- 40 °C to + 85 °C	- 40 °C to + 85 °C	- 40 °C to + 85 °C
<b>Weight (ca.)</b>	250 g	250 g	250 g
Power Management	bPMini MOST	bPMini MOST150 cPhy	bPMini FlexRay
<b>Startup time from standby to full operation</b>	ca. 25 s	ca. 25 s	ca. 25 s
<b>Start of logging - starting from standby</b>	CAN, LIN, Serial, Analog, Digital, MOST < 210 ms	CAN, LIN, Serial, Analog, Digital, MOST < 210 ms	CAN, LIN, Serial, Analog, Digital, FlexRay < 210 ms
<b>Start of logging - Ethernet / BroadR-Reach, AutoNeg off</b>	ca. 1,7s / 21s	ca. 1,7s / 21s	ca. 1,7s / 21s
<b>Standby Mode</b>	Configurable time without bus load	Configurable time without bus load	Configurable time without bus load
<b>Wake</b>	HS-CAN, LS-CAN, LIN, Serial, [ON / Trigger] button, MOST	HS-CAN, LS-CAN, LIN, Serial, [ON / Trigger] button, MOST	HS-CAN, LS-CAN, LIN, Serial, KL 15, [ON / Trigger] button, FlexRay
<b>Data loss by power loss</b>	If the device is switched off due to sudden power loss, up to 60 sec. of data may be lost.	If the device is switched off due to sudden power loss, up to 60 sec. of data may be lost.	If the device is switched off due to sudden power loss, up to 60 sec. of data may be lost.
Case	bPMini MOST	bPMini MOST150 cPhy	bPMini FlexRay
<b>Size (ca.)</b>	4,13" x 3,35" x 1,30" (105 x 85 x 33 mm)	4,13" x 3,35" x 1,30" (105 x 85 x 33 mm)	4,13" x 3,35" x 1,30" (105 x 85 x 33 mm)
<b>Operating controls</b>	Push-button to start and shut down data logger and to set markers	Push-button to start and shut down data logger and to set markers	Push-button to start and shut down data logger and to set markers
<b>LEDs (STATE, ACTIVE)</b>	Yes	Yes	Yes
Connectors	bPMini MOST	bPMini MOST150 cPhy	bPMini FlexRay
<b>Front connectors</b>	2x Gbit Ethernet, SD card, Micro--USB 2.0	2x Gbit Ethernet, SD card, Micro--USB 2.0	2x Gbit Ethernet, SD card, Micro--USB 2.0
<b>Rear connectors</b>	2x Gbit ETH	2x Gbit ETH	2x Gbit ETH

	SUB-D 15-pol: Power supply, 1x HS-CAN, 1x HS-/LS-CAN (changeable), 3x Serial, 1x Serial/ECL (mux), 2x Analog In, 2x Digital In	SUB-D 15-pol: Power supply, 1x HS-CAN, 1x HS-/LS-CAN (changeable), 3x Serial, 1x Serial/ECL (mux), 2x Analog In, 2x Digital In	SUB-D 44-pol: Power supply, 4x HS-CAN, 1x LS-CAN, 2x LIN, 5x Serial, 2x Analog In, 2x Digital In, 2x Digital Out
<b>Data recording</b>	<b>bPMini MOST</b>	<b>bPMini MOST150 cPhy</b>	<b>bPMini FlexRay</b>
<b>Storage type (internal)</b>	58 GB flash	58 GB flash	58 GB flash
<b>Storage type (external)</b>	USB flash drive SD card	USB flash drive SD card	USB flash drive SD card
<b>Recording modes</b>	Normal, ring buffer	Normal, ring buffer	Normal, ring buffer
<b>Timestamp accuracy</b>	1 µs	1 µs	1 µs
<b>MOST150 recording</b>	<b>bPMini MOST</b>	<b>bPMini MOST150 cPhy</b>	<b>bPMini FlexRay</b>
<b>Channel</b>	MDP MOST data packets, MEP MOST Ethernet packets, control channel, network status, MOST streaming (synchronous/isochronous) (optional)	MDP MOST data packets, MEP MOST Ethernet packets, control channel, network status, MOST streaming (synchronous/isochronous) (optional)	
<b>Status recording</b>	Light on/off, Lock on/off	Light on/off, Lock on/off	
<b>Filter</b>	MDP filter (source address, target address), MEP filter (target MAC address)	MDP filter (source address, target address), MEP filter (target MAC address)	
<b>CAN recording</b>	<b>bPMini MOST</b>	<b>bPMini MOST150 cPhy</b>	<b>bPMini FlexRay</b>
<b>Channel</b>	1 High Speed, 1 High/Low Speed (mixed)	1 High Speed, 1 High/Low Speed (mixed)	4 High Speed, 1 Low Speed
<b>Baud rate</b>	Up to 1000000 Baud at HS-CAN up to 125000 Baud at LS-CAN	Up to 1000000 Baud at HS-CAN up to 125000 Baud at LS-CAN	Up to 1000000 Baud at HS-CAN up to 125000 Baud at LS-CAN
<b>Transceiver</b>	TJA1041A, TJA1055T	TJA1041A, TJA1055T	TJA1041A, TJA1055T
<b>Filter</b>	CAN ID filter	CAN ID filter	CAN ID filter
<b>Status recording</b>	Error frames	Error frames	Error frames
<b>Serial recording</b>	<b>bPMini MOST</b>	<b>bPMini MOST150 cPhy</b>	<b>bPMini FlexRay</b>
<b>Type</b>	RS232	RS232	RS232
<b>Channel</b>	4	4	5
<b>Baud rate</b>	1200, 2400, 4800, 9600, 19200, 38400, 57600, 115200, 230400 Baud	1200, 2400, 4800, 9600, 19200, 38400, 57600, 115200, 230400 Baud	1200, 2400, 4800, 9600, 19200, 38400, 57600, 115200, 230400 Baud
<b>Data bits</b>	5,6,7,8	5,6,7,8	5,6,7,8
<b>Stop bits</b>	1,1.5,2	1,1.5,2	1,1.5,2
<b>Parity</b>	None, odd, even	None, odd, even	None, odd, even
<b>LIN recording</b>	<b>bPMini MOST</b>	<b>bPMini MOST150 cPhy</b>	<b>bPMini FlexRay</b>
<b>Channel</b>			2
<b>Baud rate</b>			1200, 2400, 4800, 9600, 10400, 19200, 20000 Baud
<b>Transceiver</b>			TJA1021
<b>FlexRay recording</b>	<b>bPMini MOST</b>	<b>bPMini MOST150 cPhy</b>	<b>bPMini FlexRay</b>
<b>Channel</b>			2x (a/b)
<b>Bit rate</b>			Up to 10 Mbit/s
<b>Transceiver</b>			AS8222
<b>Recording</b>			Null frames, Startup Phase, Trailer CRC, Symbol
<b>Ethernet recording</b>	<b>bPMini MOST</b>	<b>bPMini MOST150 cPhy</b>	<b>bPMini FlexRay</b>

<b>Port</b>	4	4	4
<b>Speed</b>	2x 1 Gbit/s (front side) 2x 100 Mbit/s (rear side, Protocol logging / 1 Gbit/s SPY-Mode)	2x 1 Gbit/s (front side) 2x 100 Mbit/s (rear side, Protocol logging / 1 Gbit/s SPY-Mode)	2x 1 Gbit/s (front side) 2x 100 Mbit/s (rear side, Protocol logging / 1 Gbit/s SPY-Mode)
<b>Recording</b>	GNLog, Raw, UTF8, UDP, DLT (optional), EsoTrace (optional)	GNLog, Raw, UTF8, UDP, DLT (optional), EsoTrace (optional)	GNLog, Raw, UTF8, UDP, DLT (optional), EsoTrace (optional)
<b>BroadR-Reach recording</b>			
<b>Analog recording</b>	<b>bPMini MOST</b>	<b>bPMini MOST150 cPhy</b>	<b>bPMini FlexRay</b>
<b>Channel</b>	1x Ubat (internal), 2x external	1x Ubat (internal), 2x external	1x Ubat (internal), 2x external
<b>Range of measurement</b>	Channel 1: 0V to +30V Channel 2/3: 0V to +20V	Channel 1: 0V to +30V Channel 2/3: 0V to +20V	Channel 1: 0V to +30V Channel 2/3: 0V to +20V
<b>Resolution</b>	8 mV	8 mV	8 mV
<b>Accuracy</b>	3 % 0 -16V 4 % 16 – 20 / 32V	3 % 0 -16V 4 % 16 – 20 / 32V	3 % 0 -16V 4 % 16 – 20 / 32V
<b>Sampling interval</b>	1 ms to 100 s	1 ms to 100 s	1 ms to 100 s
<b>Digital input</b>	<b>bPMini MOST</b>	<b>bPMini MOST150 cPhy</b>	<b>bPMini FlexRay</b>
<b>Channel</b>	2 (physically identical with analog input)	2 (physically identical with analog input)	2 (physically identical with analog input)
<b>Switching threshold</b>	7 V ± 0.2 V	7 V ± 0.2 V	7 V ± 0.2 V
<b>Sampling interval</b>	1 ms to 100 s	1 ms to 100 s	1 ms to 100 s
<b>Digitale output</b>	<b>bPMini MOST</b>	<b>bPMini MOST150 cPhy</b>	<b>bPMini FlexRay</b>
<b>Channel</b>			2
<b>Output voltage</b>			~ Ubat
<b>Output current</b>			Up to 1.0 A (continuous load)

**Table 13.2: Datasheet - BLUEPIRAT Mini MOST150 / MOST150 cPhy / FlexRay**

## 14 Adapter cables & pinning

This chapter describes which adapter cables are available for the **BLUEPIRAT Mini**.

We are offering adapter cables that connect to the multi-function connectors and split up its lines to separate connectors.

### Warning:

**Clamp 31 should be the only ground connection between the data logger and connected devices. Connecting signal ground lines is limited to special cases in which one can guarantee that ground loops cannot occur**

### 14.1 BLUEPIRAT Mini 8 CAN | 44-pol SUB-D cable set

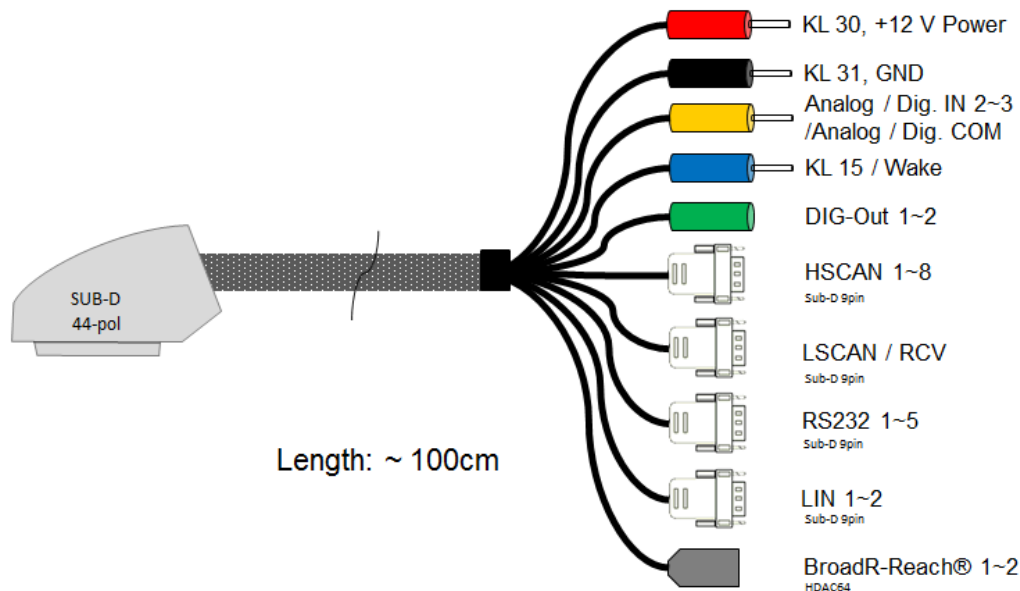

**Figure 14.1: BLUEPIRAT Mini - cable set 8 CAN**

Attention: The cable sets of BLUEPIRAT Mini 8 CAN and BLUEPIRAT Mini 4 CAN-FD have differences in the polarity of the BroadR-Reach connectors at the 44-pol SUB-D connector. Please refer to the pinning in the appendix.

#### 14.1.1 BLUEPIRAT Mini 8 CAN | 44-pol SUB-D - Plug

Name	Type	Manufacturer-Nr.	Manufacturer
SUB-D 44-pol	SUB-D 44 Pol. jack	FL25-44S7	FCT
	Crimpkontakt S110-01V	Female- S110-01V	FCT
	Haube für 44 Pol.SUB-D	FML3 K940-962	FCT
	Slidelock bPMini plug	F-GV-3h	FCT

**Table 14.1: BLUEPIRAT Mini 8 CAN | 44-pol SUB-D - Plug**



This connector is identical for the following devices, but the pinning may be different!

- BLUEPIRAT Mini 8 CAN
- BLUEPIRAT Mini 4 CAN-FD
- BLUEPIRAT Mini LIN
- BLUEPIRAT Mini FR

You can buy this plug set under Art.Nr: TM104383

### 14.1.2 BLUEPIRAT Mini 8 CAN | 44-pol SUB-D - Pin assignment

@ Logger		comment / depiction / signal name	@ Vehicle interface	
SUB-D 44-pol	Label		Type	Pin
1	HSCAN_L_0	High Speed CAN #01 LOW	DSUB-9 / male	2
2	HSCAN_H_0	High Speed CAN #01 HIGH	DSUB-9 / male	7
3	HSCAN_L_1	High Speed CAN #02 LOW	DSUB-9 / male	2
4	HSCAN_H_1	High Speed CAN #02 HIGH	DSUB-9 / male	7
5	HSCAN_L_2	High Speed CAN #03 LOW	DSUB-9 / male	2
6	HSCAN_H_2	High Speed CAN #03 HIGH	DSUB-9 / male	7
7	HSCAN_L_3	High Speed CAN #04 LOW	DSUB-9 / male	2
8	HSCAN_H_3	High Speed CAN #04 HIGH	DSUB-9 / male	7
9	HSCAN_L_4	High Speed CAN #05 LOW	DSUB-9 / male	2
10	HSCAN_H_4	High Speed CAN #05 HIGH	DSUB-9 / male	7
11	HSCAN_L_5	High Speed CAN #06 LOW	DSUB-9 / male	2
12	HSCAN_H_5	High Speed CAN #06 HIGH	DSUB-9 / male	7
13	LSCAN_L_0	Low Speed CAN LOW	DSUB-9 / male	2
14	LSCAN_H_0	Low Speed CAN HIGH	DSUB-9 / male	7
15	KL 31	power supply (-)	banana plug <b>black</b>	1
16	KL 31	power supply (-)	combined with #15	1
17	HSCAN_L_6	High Speed CAN #07 LOW	DSUB-9 / male	2
18	HSCAN_H_6	High Speed CAN #07 HIGH	DSUB-9 / male	7
19	V24 RX 0	Serial RS232 #1 RX	DSUB-9 / male	2
20	V24 TX 0	Serial RS232 #1 TX	DSUB-9 / male	3
21	V24 RX 1	Serial I RS232 #2 RX	DSUB-9 / male	2
22	V24 TX 1	Serial RS232 #2 TX	DSUB-9 / male	3
23	V24 RX 2	Serial RS232 #3 RX	DSUB-9 / male	2
24	V24 TX 2	Serial RS232 #3 TX	DSUB-9 / male	3
25	V24 RX 3	Serial RS232 #4 RX	DSUB-9 / male	2
26	V24 TX 3	Serial RS232 #4 TX	DSUB-9 / male	3
27	HSCAN_L_7	High Speed CAN #08 LOW	DSUB-9 / male	2
28	HSCAN_H_7	High Speed CAN #08 HIGH	DSUB-9 / male	7
29	KL 30	power supply (+)	combined with #30	1
30	KL 30 & -[Fuse 5 A]-	power supply (+)	banana plug <b>red</b>	1
31	KL 15	wake up from KL 15	banana plug <b>blue</b>	1

@ Logger		comment / depiction / signal name	@ Vehicle interface	
SUB-D 44-pol	Label		Type	Pin
32	LIN 0	LIN 1	DSUB-9 / male	7
33	LIN 1	LIN 2	DSUB-9 / male	7
34	ANA IN 0	Analog / Dig. Interface #2 IN	banana plug <b>yellow</b>	1
35	ANA IN 1	Analog / Dig. Interface #3 IN	banana plug <b>yellow</b>	1
36	ANA / DIG COM	Analog / Dig. Interface ground	banana plug <b>yellow</b>	1
37	BRR 0-	Broad-R-Reach 1-	MCD 5 / (white)	2
38	BRR 0+	Broad-R-Reach 1+	MCD 5 / ( <b>green</b> )	3
39	BRR 1-	Broad-R-Reach 2-	MCD 5 / (white)	2
40	BRR 1+	Broad-R-Reach 2+	MCD 5 / ( <b>green</b> )	3
41	V24 RX 4	Serial RS232 #5 RX	DSUB-9 / male	2
42	V24 TX 4	Serial RS232 #5 TX	DSUB-9 / male	3
43	DIG OUT 2	Digital OUT 2	banana jack <b>green</b>	1
44	DIG OUT 1	Digital OUT 1	banana jack <b>green</b>	1

Table 14.2: BLUEPIRAT Mini 8 CAN | 44-pol SUB-D - Pin assignment

### 14.1.3 BLUEPIRAT Mini 8 CAN | BroadR-Reach - Plug

The BroadR-Reach interfaces are implemented to the wiring harness as black connectors and labeled with **KFZ BRR 1 / KFZ BRR 2**.

- Link to Molex: [Molex 31068-1040](#)

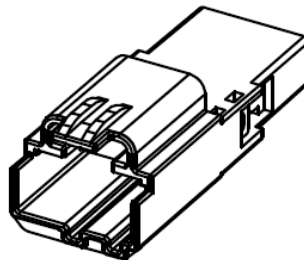

Figure 14.2: BLUEPIRAT Mini 8 CAN | BroadR-Reach plug (Molex 310681040-series)

- Mates with: [Molex 31068-1010](#)



Figure 14.3: Molex 310681010-series

### 14.2 BLUEPIRAT Mini 4 CAN-FD | 44-pol SUB-D cable set

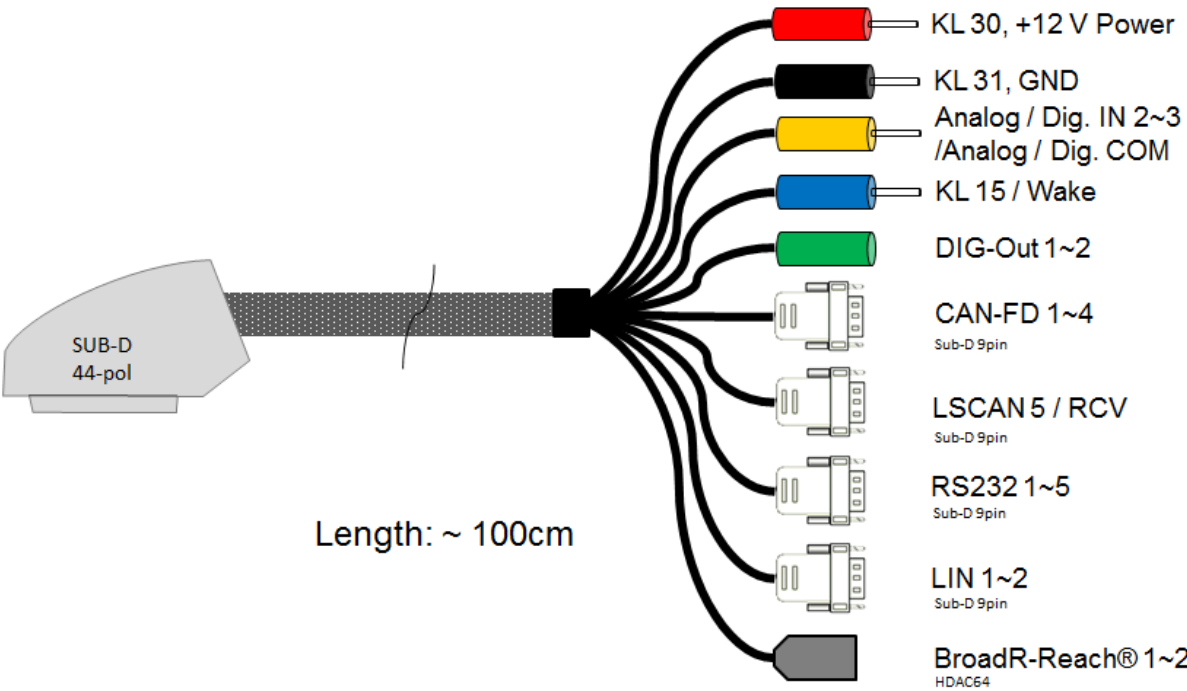

Figure 14.4: BLUEPIRAT Mini - cable set 4 CAN-FD

## 14.2.1 BLUEPIRAT Mini 4 CAN-FD | 44-pol SUB-D - Pin assignment

@ Logger SUB-D 44-pol	comment / depiction / signal name	@ Vehicle interface	
		Type	Pin
1	High Speed CAN #01 LOW	DSUB-9 / male	2
2	High Speed CAN #01 HIGH	DSUB-9 / male	7
3	High Speed CAN #02 LOW	DSUB-9 / male	2
4	High Speed CAN #02 HIGH	DSUB-9 / male	7
5	High Speed CAN #03 LOW	DSUB-9 / male	2
6	High Speed CAN #03 HIGH	DSUB-9 / male	7
7	High Speed CAN #04 LOW	DSUB-9 / male	2
8	High Speed CAN #04 HIGH	DSUB-9 / male	7
9	not connected		
10	not connected		
11	not connected		
12	not connected		
13	Low Speed CAN LOW	DSUB-9 / male	2
14	Low Speed CAN HIGH	DSUB-9 / male	7
15	power supply (-) KL 31	banana plug <b>black</b>	1
16	power supply (-) KL 31	combined with #15	1
17	not connected		
18	not connected		
19	Serial RS232 #1 RX	DSUB-9 / male	2
20	Serial RS232 #1 TX	DSUB-9 / male	3
21	Serial I RS232 #2 RX	DSUB-9 / male	2
22	Serial RS232 #2 TX	DSUB-9 / male	3
23	Serial RS232 #3 RX	DSUB-9 / male	2
24	Serial RS232 #3 TX	DSUB-9 / male	3
25	Serial RS232 #4 RX	DSUB-9 / male	2
26	Serial RS232 #4 TX	DSUB-9 / male	3
27	not connected		
28	not connected		
29	power supply (+) KL 30	combined with #30	1
30	power supply (+) KL 30 & -[Fuse 5 A]-	banana plug <b>red</b>	1
31	wake up from KL 15	banana plug <b>blue</b>	1
32	LIN 1	DSUB-9 / male	7
33	LIN 2	DSUB-9 / male	7
34	Analog / Dig. Interface #2 IN	banana plug <b>yellow</b>	1
35	Analog / Dig. Interface #3 IN	banana plug <b>yellow</b>	1
36	Analog / Dig. Interface ground	banana plug <b>yellow</b>	1
37	Broad-R-Reach 1+	MCD 5 / (green)	3
38	Broad-R-Reach 1-	MCD 5 / (white)	2
39	Broad-R-Reach 2+	MCD 5 / (green)	3
40	Broad-R-Reach 2-	MCD 5 / (white)	2
41	Serial RS232 #5 RX	DSUB-9 / male	2
42	Serial RS232 #5 TX	DSUB-9 / male	3
43	Digital OUT 2	banana jack <b>green</b>	1
44	Digital OUT 1	banana jack <b>green</b>	1

Table 14.3: BLUEPIRAT Mini 4 CAN-FD | 44-pol SUB-D - Pin assignment

### 14.3 BLUEPIRAT Mini 8 LIN | 44-pol SUB-D cable set

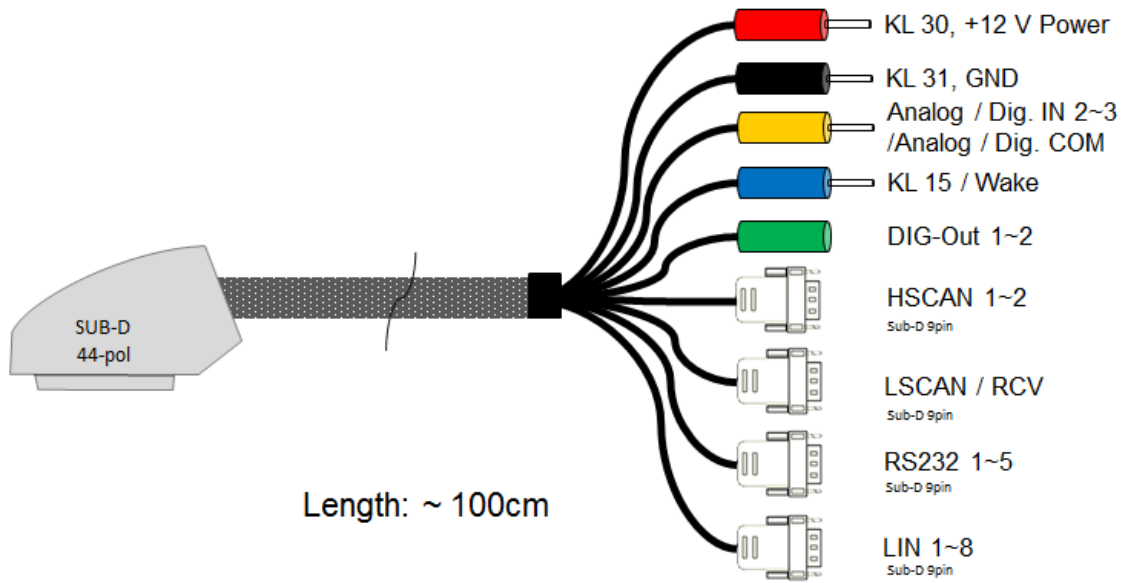

Figure 14.5: BLUEPIRAT Mini - cable set 9 LIN

### 14.3.1.1 BLUEPIRAT Mini 8 LIN | 44-pol SUB-D - Pin assignment

SUB-D 44-pol	@ Logger comment / depiction / signal name	@ Vehicle interface	
		Type	Pin
1	High Speed CAN #01 LOW	DSUB-9 / male	2
2	High Speed CAN #01 HIGH	DSUB-9 / male	7
3	High Speed CAN #02 LOW	DSUB-9 / male	2
4	High Speed CAN #02 HIGH	DSUB-9 / male	7
5	not connected		
6	LIN 3	DSUB-9 / male	7
7	LIN 4	DSUB-9 / male	7
8	LIN 5	DSUB-9 / male	7
9	LIN 6	DSUB-9 / male	7
10	LIN 7	DSUB-9 / male	7
11	LIN 8	DSUB-9 / male	7
12	not connected		
13	Low Speed CAN LOW	DSUB-9 / male	2
14	Low Speed CAN HIGH	DSUB-9 / male	7
15	power supply (-) KL 31	banana plug <b>black</b>	1
16	power supply (-) KL 31	combined with #15	1
17	not connected		
18	not connected		
19	Serial RS232 #1 RX	DSUB-9 / male	2
20	Serial RS232 #1 TX	DSUB-9 / male	3
21	Serial RS232 #2 RX	DSUB-9 / male	2
22	Serial RS232 #2 TX	DSUB-9 / male	3
23	Serial RS232 #3 RX	DSUB-9 / male	2
24	Serial RS232 #3 TX	DSUB-9 / male	3
25	Serial RS232 #4 RX	DSUB-9 / male	2
26	Serial RS232 #4 TX	DSUB-9 / male	3
27	not connected		
28	not connected		
29	power supply (+) KL 30	combined with #30	1
30	power supply (+) KL 30 & -[Fuse 5 A]-	banana plug <b>red</b>	1
31	wake up from KL15	banana plug <b>blue</b>	1
32	LIN 1	DSUB-9 / male	7
33	LIN 2	DSUB-9 / male	7
34	Analog / Dig. Interface #2 IN	banana plug <b>yellow</b>	1
35	Analog / Dig. Interface #3 IN	banana plug <b>yellow</b>	1
36	Analog / Dig. Interface ground	banana plug <b>yellow</b>	1
37	not connected		
38	not connected		
39	not connected		
40	not connected		
41	Serial RS232 #5 RX	DSUB-9 / male	2
42	Serial RS232 #5 TX	DSUB-9 / male	3
43	Digital OUT 2	banana jack <b>green</b>	1
44	Digital OUT 1	banana jack <b>green</b>	1

Table 14.4: BLUEPIRAT Mini 8 LIN | 44-pol SUB-D - Pin assignment

## 14.4 BLUEPIRAT Mini 20 LIN | 44-pol SUB-D cable set

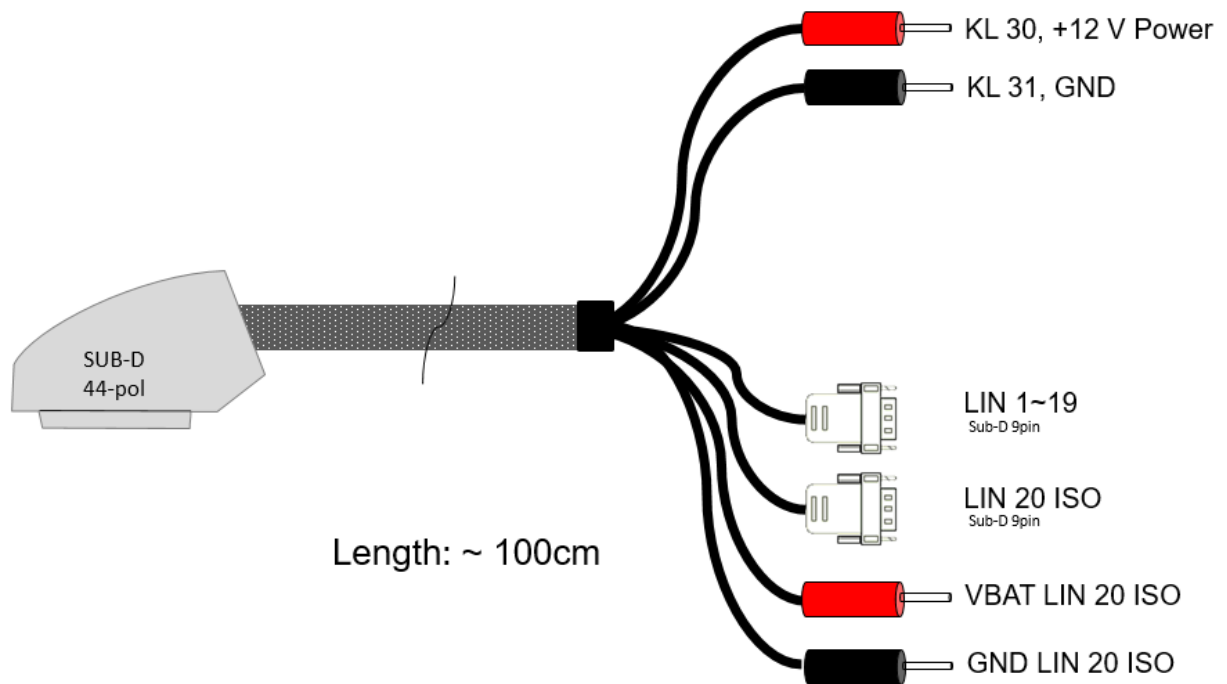

Figure 14.6: BLUEPIRAT Mini - cable set 20 LIN

**Attention:** The BLUEPIRAT Mini 20 LIN has one special LIN interface (LIN #20) which needs a separate power supply. This power connectors are part of the cable set.

### 14.4.1 BLUEPIRAT Mini 20 LIN | 44-pol SUB-D - Pin assignment

SUB-D 44-pol	@ Logger comment / depiction / signal name	@ Vehicle interface	
		Type	Pin
1	not connected		
2	not connected		
3	not connected		
4	not connected		
5	not connected		
6	LIN 3	DSUB-9 / male	7
7	LIN 4	DSUB-9 / male	7
8	LIN 5	DSUB-9 / male	7
9	LIN 6	DSUB-9 / male	7
10	LIN 7	DSUB-9 / male	7
11	LIN 8	DSUB-9 / male	7
12	LIN 9	DSUB-9 / male	7
13	not connected		
14	not connected		
15	power supply (-) KI 31	banana plug <b>black</b>	1
16	power supply (-) KI 31	combined with #15	1
17	LIN 10	DSUB-9 / male	7
18	LIN 11	DSUB-9 / male	7
19	not connected		
20	not connected		
21	LIN 12	DSUB-9 / male	7
22	LIN 13	DSUB-9 / male	7
23	LIN 14	DSUB-9 / male	7
24	LIN 15	DSUB-9 / male	7
25	LIN 16	DSUB-9 / male	7
26	LIN 17	DSUB-9 / male	7
27	LIN 18	DSUB-9 / male	7
28	LIN 19	DSUB-9 / male	7
29	power supply (+) KL 30	combined with #29	1
30	power supply (+) KL 30 & -[Fuse 5 A]-	banana plug <b>red</b>	1
31	not connected		
32	LIN 1	DSUB-9 / male	7
33	LIN 2	DSUB-9 / male	7
34	not connected		
35	not connected		
36	not connected		
37	not connected		
38	not connected		
39	VBAT LIN 20 ISO	banana plug <b>red</b>	1
40	not connected		
41	GND LIN 20 ISO	banana plug <b>black</b>	1
42	LIN 20 ISO	DSUB-9 / male	3
43	not connected		
44	not connected		

Table 14.5: BLUEPIRAT Mini 20 LIN | 44-pol SUB-D - Pin assignment



## 14.6 BLUEPIRAT Mini FlexRay | 44-pol SUB-D cable set

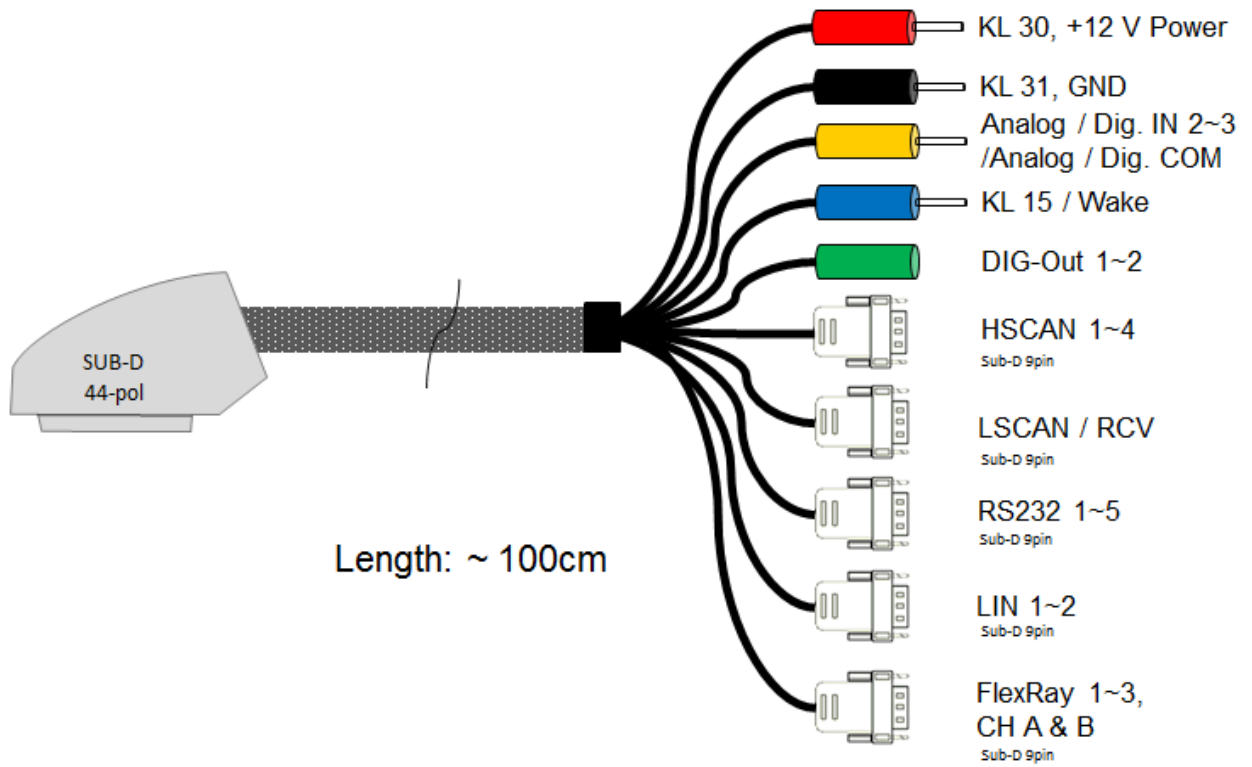

Figure 14.7: BLUEPIRAT Mini - cable set FlexRay

## 14.6.1 BLUEPIRAT Mini FlexRay | 44-pol SUB-D - Pin assignment

@ Logger SUB-D 44-pol	comment / depiction / signal name	@ Vehicle interface	
		Type	Pin
1	High Speed CAN #01 LOW	DSUB-9 / male	2
2	High Speed CAN #01 HIGH	DSUB-9 / male	7
3	High Speed CAN #02 LOW	DSUB-9 / male	2
4	High Speed CAN #02 HIGH	DSUB-9 / male	7
5	High Speed CAN #03 LOW	DSUB-9 / male	2
6	High Speed CAN #03 HIGH	DSUB-9 / male	7
7	High Speed CAN #04 LOW	DSUB-9 / male	2
8	High Speed CAN #04 HIGH	DSUB-9 / male	7
9	FlexRay+ Channel 1a	DSUB-9 / male	7
10	FlexRay- Channel 1a	DSUB-9 / male	2
11	FlexRay+ Channel 1b	DSUB-9 / male	7
12	FlexRay- Channel 1b	DSUB-9 / male	2
13	Low Speed CAN LOW	DSUB-9 / male	2
14	Low Speed CAN HIGH	DSUB-9 / male	7
15	power supply (-) KL 31	banana plug <b>black</b>	1
16	power supply (-) KL 31	combined with #15	1
17	not used		
18	not used		
19	Serial RS232 #1 RX	DSUB-9 / male	2
20	Serial RS232 #1 TX	DSUB-9 / male	3
21	Serial RS232 #2 RX	DSUB-9 / male	2
22	Serial RS232 #2 TX	DSUB-9 / male	3
23	Serial RS232 #3 RX	DSUB-9 / male	2
24	Serial RS232 #3 TX	DSUB-9 / male	3
25	Serial RS232 #4 RX	DSUB-9 / male	2
26	Serial RS232 #4 TX	DSUB-9 / male	3
27	FlexRay+ Channel 3b	DSUB-9 / male	7
28	FlexRay- Channel 3b	DSUB-9 / male	2
29	power supply (+) KL 30	combined with #30	1
30	power supply (+) KL 30 & -[Fuse 5 A]-	banana plug <b>red</b>	1
31	wake up from KL15	banana plug <b>blue</b>	1
32	LIN 1	DSUB-9 / male	7
33	LIN 2	DSUB-9 / male	7
34	Analog / Dig. Interface #2 IN	banana plug <b>yellow</b>	1
35	Analog / Dig. Interface #3 IN	banana plug <b>yellow</b>	1
36	Analog / Dig. Interface ground	banana plug <b>yellow</b>	1
37	FlexRay+ Channel 2a	DSUB-9 / male	7
38	FlexRay- Channel 2a	DSUB-9 / male	2
39	FlexRay+ Channel 2b	DSUB-9 / male	7
40	FlexRay- Channel 2b	DSUB-9 / male	2
41	Serial RS232 #5 RX	DSUB-9 / male	2
42	Serial RS232 #5 TX	DSUB-9 / male	3
43	Digital OUT 2	banana jack <b>green</b>	1
44	Digital OUT 1	banana jack <b>green</b>	1

Table 14.6: BLUEPIRAT Mini FlexRay | 44-pol SUB-D - Pin assignment

## 14.8 BLUEPIRAT Mini MOST / cPhy | 15-pol SUB-D – cable set

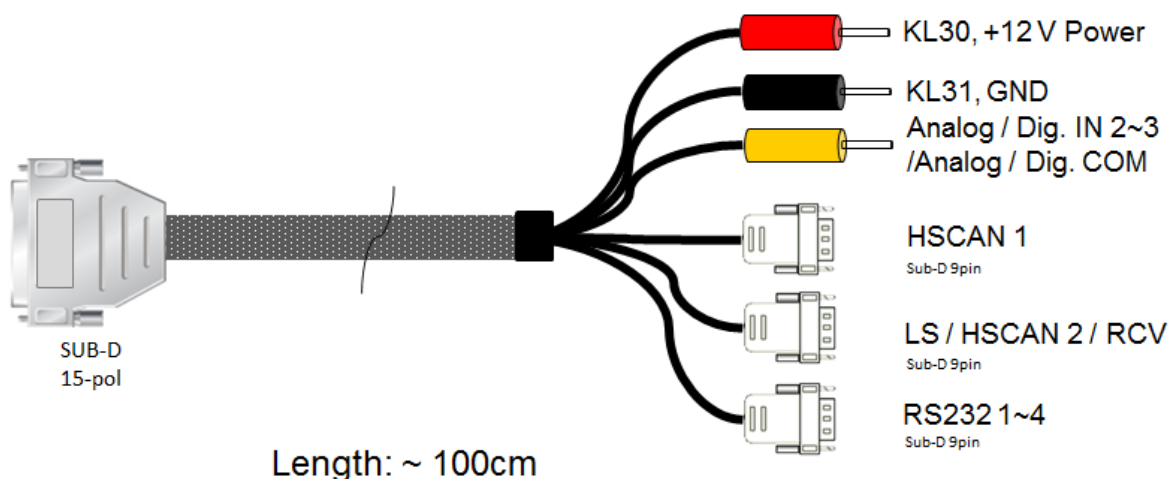

Figure 14.8: BLUEPIRAT Mini - cable set MOST150

### 14.8.1 BLUEPIRAT Mini MOST / cPhy | 15-pol SUB-D – Plug

Name	Type	Manufacturer-Nr.	Manufacturer
SUB-D 15-pol	Sub D 15 Pol. jack		FCT
	Crimp contact S110-01V	FCT-Female- S110-01V	FCT
	Sub D hood 9 Pol.	FCT-FMK1-189	FCT
	Sub D 9 Pol. slide closure	F-GV-1H	FCT

Table 15.6: BLUEPIRAT Mini MOST / cPhy | 15-pol SUB-D – Plug

You can buy this plug set under Art.Nr: TM104384

## 14.8.2 BLUEPIRAT Mini MOST / cPhy | 15-pol SUB-D - Pin assignment

@ Logger SUB-D 15-pol	comment / depiction / signal name	@ Vehicle interface	
		Type	Pin
1	High Speed CAN #01 LOW	DSUB-9 / male	2
2	High Speed CAN #01 HIGH	DSUB-9 / male	7
3	HS / LS CAN #02 LOW	DSUB-9 / male	2
4	HS / LS CAN #02 HIGH	DSUB-9 / male	7
5	power supply (-) KL 31	banana plug <b>black</b>	1
6	power supply (-) KL 31	combined with #5	1
7	Serial RS232 #1 RX	DSUB-9 / male	2
8	Serial RS232 #2 RX	DSUB-9 / male	2
9	power supply (+) KL 30	combined with #10	1
10	power supply (+) KL 30 & -[Fuse 5 A]-	banana plug <b>red</b>	1
11	RS232 #3 RX	DSUB-9 / male	2
12	RS232 #4 RX / ECL	DSUB-9 / male	2
13	Analog / Dig. Interface #2 IN	banana plug <b>yellow</b>	1
14	Analog / Dig. Interface #3 IN	banana plug <b>yellow</b>	1
15	Analog / Dig. Interface ground	banana plug <b>yellow</b>	1

Table 14.7: BLUEPIRAT Mini MOST / cPhy | 15-pol SUB-D - Pin assignment

## 14.8.3 MOST25 / 150 Connector (optical)

Name	Typ	Hersteller-Nr.	Hersteller
MOST25 / MOST150	Fiber Optic Connector	TYCO-1355426	TYCO

Table 14.8: MOST25 / MOST150 Connector (optical)

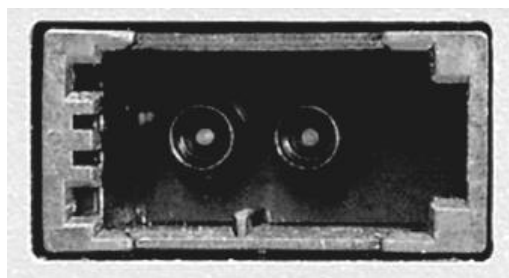

Figure 14.9: MOST25 / MOST150 Connector (optical)

## 14.8.4 MOST150 cPhy Connector (electrical)

Name	Typ	Hersteller-Nr.	Hersteller
MOST150 cPhy	FAKRA - HF	59S20X-40ML5-Y	Rosenberger

Table 14.9: MOST150 cPhy Connector (electrical)

59S20X-40ML5-Y	Signal
1	RX / TX
2	Gnd
3	Gnd
4	Gnd
5	Gnd

**Table 14.10: Pinning MOST150 cPhy Connector (electrical)**



**Figure 14.10: MOST150 cPhy Connector, electrical Simplex / Duplex**

## 14.9 Note for serial measurements

**Note:**

The BLUEPIRAT Mini actively sends data on the “Tx” line, if a protocol for the serial port is configured. The “Tx” line must only be connected to special devices that support those protocols. If the application is listening to a bidirectional serial communication of two devices, two serial ports of the BLUEPIRAT Mini have to be used. The “Tx” lines must not be connected in this case.

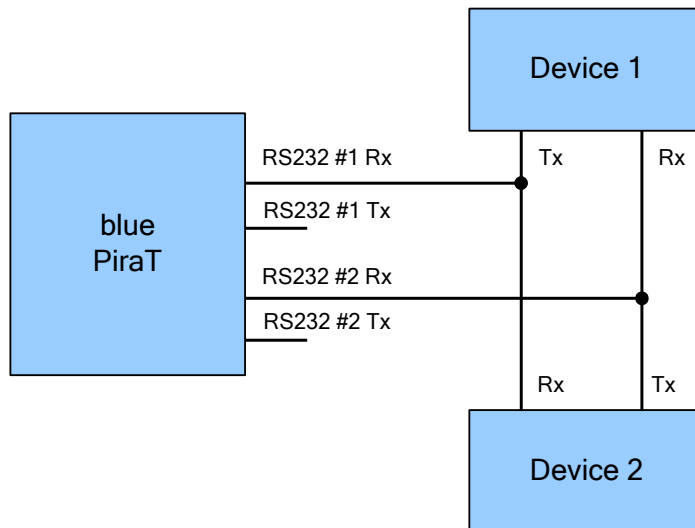

Figure 14.11: Listening to a bidirectional serial communication

## 14.10 RJ45 Ethernet connector

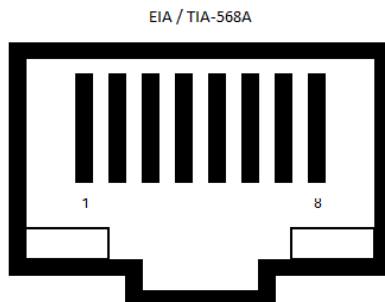
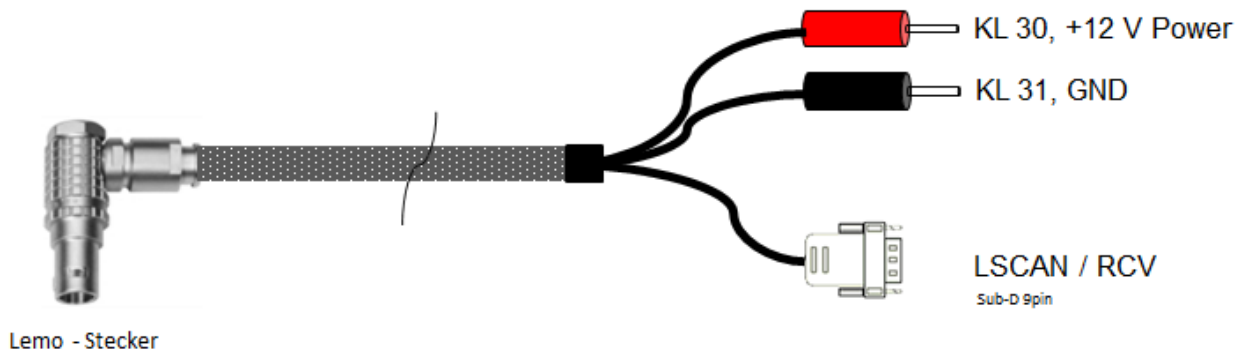

Figure 14.12: Pinout of RJ45 Ethernet connectors

Pin	Signal
1	TX1+
2	TX1-
3	TX2+
4	TX3+
5	TX3-
6	TX2-
7	TX4+
8	TX4-

Table 15.10: Pinout of the RJ45 connectors

## 14.11 Adapter cable for Remote Control Voice (RCV)



Length: ~ 300cm

Figure 14.13: Adapter cable for Remote Control Voice

[Index](#)

## 15 Support

If problems occur with a product from Magna Telemotive GmbH, please take following steps:

- Read the User Manual
- Please check if you are using an up-to-date software
- Please check if all cables are correctly attached to the data logger
- If you are able to establish a connection to the data logger, run the program "Bug Reporter" in the System Client. This program creates a zip file, which you should please put into a ticket into our [OTRS Ticket system](#)
- Contact Customer Support at [TMO.productsupport@magna.com](mailto:TMO.productsupport@magna.com) (+49 89 357186-518)

### 15.1 Service Center

In our Service Center you will find the newest firmware versions and the latest version of the System Client as well as older versions for download. In addition, we offer detailed documents and specifications for our current products.

There are two ways to reach the service center:

1. Using the current link:

<https://sc.telemotive.de/4/index.php?id=154&L=1>

2. Go to the Telemotive homepage and use the login link top right.

<http://www.telemotive.de>

**Note:** If you do not have an account for our service center and OTRS ticket system, please send a mail to [TMO.Produktsupport@magna.com](mailto:TMO.Produktsupport@magna.com) and we will generate an account for you.

### 15.2 OTRS Ticket system

With the login data for the service center you have access to our OTRS-Ticket system too. Every email sent to [TMO.productsupport@magna.com](mailto:TMO.productsupport@magna.com) generates automatically a ticket and can therefore be forwarded to the responsible person promptly.

At <https://produktsupport.telemotive.de> the status of your tickets can be checked fast and easily.

You can log in using your access data above. Creation of new tickets is also possible as upload a bugreport. The most important steps are described in a manual that can be found in the upper right corner of the website or under this link directly:

[https://sc.telemotive.de/4/uploads/media/OTRS\\_Kurzanleitung.pdf](https://sc.telemotive.de/4/uploads/media/OTRS_Kurzanleitung.pdf)

**Note:** If you want to upload more than 20 MB please create a ticket first and upload the file in a second step without the limitation.



## 15.2.1 What is OTRS?

The Open Ticket Request System (OTRS) of MAGNA Telemotive GmbH enables our customers to send inquiries and to report problems in a fast and easy way to our Customer Support, and to monitor these inquiries via a proprietary account. The personal login-area also offers the possibility to upload files to the corresponding inquiry.

## 15.2.2 Needed information in a ticket

If you notice any behavior with a MAGNA Telemotive GmbH product that does not correspond to the expected process, you are welcome to inform us via our ticket system.

Please report only one problem per ticket and do not create collective tickets to keep a clear overview.

In order to keep the processing time as short as possible for both sides, we would like to ask you to provide the following data when creating the ticket, so that the analysis can take place promptly.

### 15.2.2.1 Ticket | Checklist

- Observed behavior
- Exact time
- Used hardware
- Which system client / firmware version was used
- Location
- Reproducibility
- Last Steps
- Screenshots
- Error Report
- Offline data set

### 15.2.2.2 The points in detail

#### Observed behavior

What exactly have you observed that does not match the behavior you expected or described in the manual?

#### Exact time

The most accurate possible time when an unexpected behavior was observed.

Please always remember: Since we do not know which tests you are doing at what time, a concrete error time is absolutely necessary for the analysis. Without this information, an effective analysis is unfortunately not possible.

#### Used hardware

A list of the exact devices you were using when you observed the behavior. Is it a single device or a TSL group? If so, with which TSL participants and in which order are they connected?

#### Which system client / firmware version

Exact information about the version of the system client and the firmware used is also important, since it could possibly be a known problem in an older version. It is also important to specify whether you process data with the System Client, the Download Terminal or the ClientLib.

#### Location

Was the behavior observed in a vehicle or in a test system?

#### Reproducibility

Has the problem occurred once, or can it be reproduced with defined steps? Does the behavior occur with one or more setups?

Does the problem still occur after a restart and can it possibly be solved by a firmware update?

#### Last Steps

What was done last before this behavior was observed?

#### Screenshots

Screenshots can often explain something faster than words, so screenshots of the problem are always welcome to show or compare something. Especially for screenshots from your own tools please include an explanation of the values / representation.

#### Error report

An error report of the device / TSL network contains internal logs of the devices, the configuration, the error report of the system client with which the error report was created and optionally trace data. This combination helps us to understand what happened in the device at the specified time.

The creation of an error report is described in detail in the [User Manual of the System Client](#).

#### Offline data set

Especially if you have the feeling that something is wrong with the recording or conversion of the data, we also need an offline data set to be able to reproduce / analyze the problem.

The creation of an offline dataset is described in detail in the [User manual of the System Client](#).

### 15.2.3 Sending Inquiries

You can send inquiries as usual via your own email client to [TMO.Productsupport@magna.com](mailto:TMO.Productsupport@magna.com). This email arrives automatically the OTRS and generates a ticket. Furthermore you can write inquiries directly in the Open Ticket Request System (OTRS).

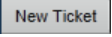
By clicking on the button  you can create a new ticket directly in your personal login-area at <https://produktsupport.telemotive.de>.

### 15.2.4 Login and Initial Steps

You can find the OTRS ticket system of Telemotive AG at <https://produktsupport.telemotive.de>.

There you can login to the OTRS using your access data, which you already use in the Service Center of MAGNA Telemotive GmbH.

After a successful login you will see a screen (see image 1), in which you can manage further activities.



**Figure 15.1: OTRS Ticket system**

By clicking on the button  you can adjust language and view settings.

This screen also gives you an overview of your current tickets.

Shortly after the submission of an inquiry, you will find the corresponding ticket in your personal account.

If there is more than one ticket in your account, all tickets are listed by date.

You can see the content of the sent message by clicking on the corresponding ticket.

As soon as you receive a new message from the Customer Support, it will be shown in your personal login-area. In addition, you will receive an email.

### 15.2.5 Adding Files

You have different possibilities to add files to a ticket. You can add files, such as error reports or screenshots immediately when a new ticket is created by clicking on the button

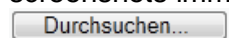

#### **Warning:**

**There's a limitation up to 20 MB like in an e-mail. If you want to upload bigger files please upload these in the next step.**

You can also upload an error report or trace files to your problem description afterwards.

By clicking on the button **Dateiupload / Fileupload** in the main screen of the login-area a new screen opens (see image 2).

With the button **Add files** you can choose your desired files for the upload. The upload can be started by using the button **Start upload**.

The upload of the file will be shown in your personal login-area.

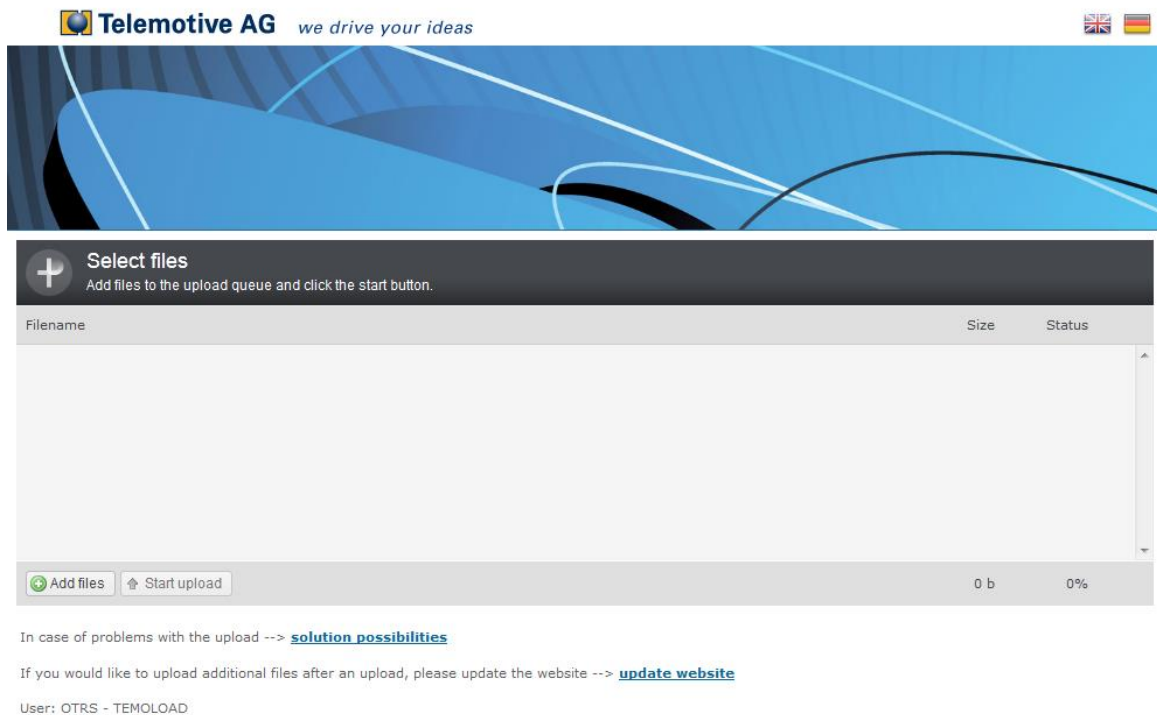

**Figure 15.2:**

## 15.2.6 Search Function

To search for a particular ticket, you can define your search criteria over the button **Search**. These criteria can be saved as a template.

## 15.2.7 Closing a ticket

In case that a problem description shall not be processed any longer, you can close the ticket yourself by clicking on the button **Reply** in the main screen of the login-area. Here you can change your status to “closed” and add a comment.

## 15.2.8 Contact

If you have any questions regarding the login or the procedure, please contact our Customer Support at [TMO.Productsupport@magna.com](mailto:TMO.Productsupport@magna.com).

## 15.3 Sending in defective devices

If your device needs to be return for repair, please complete the Service report for the device, print it out and send it with the defective device directly to Mühlhausen for repair.

### 15.3.1 Service report

The service report is available as Word and PFD file:

Word: [MagnaTelemotive-Servicereport.doc](#)

PDF: [MagnaTelemotive-Servicereport.pdf](#)

**Note:** Please note that no repair can be performed if the service report is missing or incomplete. A separate form is required for 'each' device!

### 15.3.2 Shipping address

**Shipping address for repair devices:**

MAGNA Telemotive GmbH  
to. Repair department  
Heidemannstr. 166  
80939 Munich

-Germany-

- Please make sure to ship the package on the basis of DDP (Delivery Duty Paid) and that the total value of the loggers in the pro forma invoice is under 1000 euros.
- The logger will be analysed and, if it is still in warranty, repaired and shipped back to you. If the devices warranty is expired we will send you a quotation for the repair.
- Please note that in the case of rejected quotations, the costs for analysis, function test and shipping will be charged in form of a service charge of 205€ per data logger.
- If you need help with shipping due to the included batteries, please follow the instructions in our [BatteryGuide!](#)

**Attention: On devices with internal memory the data will be deleted after the repair!**

You can find this information as well on our website at  
<https://sc.telemotive.de/4/en/servicecenter/faqs-support/support/>

### 15.3.3 Batteries:

If you need help with shipping due to the included batteries, please follow the instructions in our [BatteryGuide!](#)

(<https://sc.telemotive.de/4/fileadmin/bluepirat/support/BatteryGuide.pdf>)

## 16 Abbreviations

Kürzel / abbreviation	Bedeutung / meaning
blue PiraT	Processing Information Recording Analyzing Tool
bP	blue PiraT => BLUEPIRAT
bP2	blue PiraT2 => BLUEPIRAT2
bP2 5E	blue PiraT2 5E => BLUEPIRAT2 5E
bPMini	blue PiraT Mini => BLUEPIRAT Mini
RC Touch	Remote Control Touch
bP Remote	blue PiraT Remote => BLUEPIRAT Remote
bP Rapid	BLUEPIRAT Rapid
A2L	ASAM MCD-2 MC Language
AE	Automotive Electronics
ACK	ACKnowledged
CAN	Controller Area Network
CCP	CAN Calibration Protocol
CF	Compact Flash
CRO	Command Receive Object
DAQ	Data Acquisition
DTO	Data Transmission Object
ECL	Electrical Control Line
ECU	Electronic Control Unit
FIBEX	Field Bus Exchange Format
FW	Firmware
GMT	Greenwich Mean Time
INCA	INtegrated Calibration and Application Tool
LAN	Local Area Network = Netzwerk
LIN	Local Interconnect Network
MAC	<b>M</b> edia <b>A</b> ccess <b>C</b> ontrol
MCD	<b>M</b> easure <b>C</b> alibrate <b>D</b> iagnose
MDX	<b>M</b> eta <b>D</b> ata <b>E</b> Xchange Format
MEP	<b>M</b> OST Ethernet Packet
MOST	Media Oriented Systems Transport ( <a href="http://www.mostnet.de">www.mostnet.de</a> )
ODT	<b>O</b> bject <b>D</b> escriptor <b>T</b> able
ODX	<b>O</b> pen <b>D</b> ata <b>E</b> Xchange
OEM	<b>O</b> riginal <b>E</b> quipment <b>M</b> anufacturer

PHY	<b>PHY</b> sical Bus Connect
PW	Passwort
RX	Receiver Data
SD	Secure Digital
SFTP	Secure File Transfer Protocol
SHA	Secure Hash
SSL	Secure Sockets Layer
TCP/IP	Transmission Control Protocol/Internet Protocol
TLS	Transport Layer Security
tmt	Telemotive Trace
bPP	blue PiraT Packetformat
bPSA	blue PiraT System Access
bPSL	blue PiraT System Link
UDP	User Datagram Protocol
USB	Universal Serial Bus
UTC	Universal Time, Coordinated
Wi-Fi	<b>Wi</b> reless <b>Fi</b> delity
WLAN	<b>Wi</b> reless <b>L</b> ocal <b>A</b> rea <b>N</b> etwork
XCP	Universal Measurement and Calibration Protocol
xtmt	eXtended Telemotive Trace

**Table 16.1: Abbreviations**

## 17 List of figures

Figure 4.1: links to the manuals in the System Client .....	9
Figure 5.1: Interface (overview) .....	12
Figure 6.1: Front panel of the BLUEPIRAT Mini .....	15
Figure 6.2: Rear side of the BLUEPIRAT Mini 8 CAN / 4 CAN-FD / 8 LIN / FlexRay / 20 LIN ...	15
Figure 6.3: Rear side of the BLUEPIRAT Mini MOST150 / MOST150 cPhy (Simplex / Duplex)	15
Figure 8.1: Power connection .....	22
Figure 8.2: Switching on the BLUEPIRAT Mini .....	22
Figure 8.3: Client Portal.....	23
Figure 8.4: Desktop icon.....	24
Figure 8.5: Content of the portable client.....	24
Figure 8.6: Change IP settings .....	26
Figure 9.1: General settings .....	28
Figure 9.2: Setting Trigger with Digital Input .....	28
Figure 10.1: Notification message due to use of LS-CAN channel for Remote Control .....	32
Figure 14.1: BLUEPIRAT Mini - cable set 8 CAN .....	48
Figure 14.2: BLUEPIRAT Mini 8 CAN   BroadR-Reach plug (Molex 310681040-series).....	50
Figure 14.3: Molex 310681010-series .....	50
Figure 14.4: BLUEPIRAT Mini - cable set 4 CAN-FD .....	51
Figure 14.5: BLUEPIRAT Mini - cable set 9 LIN .....	53
Figure 14.6: BLUEPIRAT Mini - cable set 20 LIN .....	55
Figure 14.7: BLUEPIRAT Mini - cable set FlexRay .....	57
Figure 14.8: BLUEPIRAT Mini - cable set MOST150.....	59
Figure 14.9: MOST25 / MOST150 Connector (optical) .....	60
Figure 14.10: MOST150 cPhy Connector, electrical Simplex / Duplex.....	61
Figure 14.11: Listening to a bidirectional serial communication .....	62
Figure 14.12: Pinout of RJ45 Ethernet connectors .....	62
Figure 14.13: Adapter cable for Remote Control Voice.....	63
Figure 15.1: OTRS Ticket system.....	67
Figure 15.2: .....	68

[Index](#)



## 18 List of tables

Table 4.1: Additional features by optional licenses .....	10
Table 6.1: Versions of the BLUEPIRAT Mini data logger .....	14
Table 7.1: Overview of the functions of the [ON / Trigger] button.....	16
Table 7.2: ACTIVE-LED .....	16
Table 7.3: STATE-LED.....	17
Table 7.4: Compatible SD cards.....	19
Table 9.1: Accuracy of marker.....	29
Table 9.2: Standby mode .....	30
Table 10.1: CAN.....	31
Table 10.2: LIN.....	33
Table 10.3: Serial interface.....	34
Table 10.4: FlexRay .....	34
Table 10.5: MOST150 data logging .....	37
Table 11.1: Conversion options (overview).....	39
Table 13.1: Datasheet - BLUEPIRAT Mini 8 CAN / 4 CAN-FD / 8 LIN / 20 LIN.....	44
Table 13.2: Datasheet - BLUEPIRAT Mini MOST150 / MOST150 cPhy / FlexRay .....	47
Table 14.1: BLUEPIRAT Mini 8 CAN   44-pol SUB-D - Plug.....	48
Table 14.2: BLUEPIRAT Mini 8 CAN   44-pol SUB-D - Pin assignment.....	50
Table 14.3: BLUEPIRAT Mini 4 CAN-FD   44-pol SUB-D - Pin assignment.....	52
Table 14.4: BLUEPIRAT Mini 8 LIN   44-pol SUB-D - Pin assignment.....	54
Table 14.5: BLUEPIRAT Mini 20 LIN   44-pol SUB-D - Pin assignment.....	56
Table 14.6: BLUEPIRAT Mini FlexRay   44-pol SUB-D - Pin assignment .....	58
Table 14.7: BLUEPIRAT Mini MOST / cPhy   15-pol SUB-D - Pin assignment .....	60
Table 14.8: MOST25 / MOST150 Connector (optical) .....	60
Table 14.9: MOST150 cPhy Connector (electrical).....	60
Table 14.10: Pinning MOST150 cPhy Connector (electrical) .....	61
Table 16.1: Abbreviations.....	71

[Index](#)

## 19 Contact



DRIVING **EXCELLENCE.**  
INSPIRING **INNOVATION.**

### **MAGNA Telemotive GmbH**

Main Office München  
Weimarer Straße 11  
80807 München / Germany

Tel.: +49 89 357186-0  
Fax.: +49 89 357186-520  
E-Mail: [TMO.info@magna.com](mailto:TMO.info@magna.com)  
Web: [www.telemotive.de](http://www.telemotive.de)

Sales  
E-Mail: [TMO.Sales@magna.com](mailto:TMO.Sales@magna.com)

Support  
Tel.: +49 89 357186-518  
E-Mail: [TMO.productsupport@magna.com](mailto:TMO.productsupport@magna.com)  
Service Center: <https://sc.telemotive.de/bluepirat>

© by MAGNA Telemotive GmbH

Subject to errors and to technical changes as part of product improvement.