



BLUEPIRAT







BY MAGNA













Remote Control Touch / BLUEPIRAT Remote User Manual / 30.09.2020

Version 5.0.1

Table of contents

| | | |
|----------|--|-----------|
| 1 | LICENSE AGREEMENT | 5 |
| 2 | PRODUCT LIABILITY | 6 |
| 2.1 | Terms and Conditions of Sale and Delivery | 6 |
| 2.2 | Important operating instructions..... | 6 |
| 3 | Overview..... | 7 |
| 4 | System requirements | 8 |
| 4.1 | Further manuals..... | 9 |
| 4.2 | Additional features by optional licenses | 10 |
| 4.3 | Firmware Care | 11 |
| 5 | Remote Control Touch / BLUEPIRAT Remote – hardware | 12 |
| 5.1 | Position of connectors and operating elements | 12 |
| 5.1.1 | Top view..... | 12 |
| 5.1.2 | Side view, from the right..... | 12 |
| 5.1.3 | Rear side..... | 13 |
| 5.2 | Functionality of connectors and operating elements..... | 14 |
| 5.2.1 | Ports..... | 14 |
| 5.2.2 | Brightness sensor..... | 14 |
| 5.2.2.1 | Night mode | 14 |
| 5.2.3 | Home button..... | 14 |
| 5.2.4 | Speaker..... | 15 |
| 5.2.5 | LEDs | 15 |
| 5.2.6 | Microphone | 15 |
| 5.2.7 | Touchscreen | 15 |
| 5.2.8 | Micro-USB port..... | 16 |
| 5.2.8.1 | USB storage (at BLUEPIRAT Remote only):..... | 16 |
| 5.2.9 | SD card slot (BLUEPIRAT Remote only) | 16 |
| 5.3 | Accessories | 18 |
| 5.4 | Installation..... | 18 |
| 5.4.1 | Cable connection..... | 18 |
| 5.4.1.1 | In the network | 18 |
| 5.5 | Download and installation of the System Client..... | 19 |
| 5.6 | System Client portable..... | 20 |
| 5.7 | Default network settings..... | 20 |
| 5.8 | Terminal IP address..... | 21 |
| 5.9 | Connecting the RCTouch / bP Remote with a data logger..... | 22 |
| 5.9.1 | Configure the network settings | 22 |
| 5.9.2 | Activating System Link (TSL)..... | 23 |
| 5.10 | Resetting the network settings..... | 24 |
| 5.11 | Wake up the Remote Control Touch over KI 15..... | 25 |
| 5.11.1 | Configuration before firmware version 03.02.01 | 25 |
| 6 | User Interface..... | 27 |
| 6.1 | Layout of the views | 28 |
| 6.1.1 | Header bar | 28 |
| 6.1.1.1 | Warning messages | 29 |
| 6.1.2 | Side menu..... | 30 |
| 6.1.3 | Tab bar..... | 30 |
| 6.2 | Applications       | 31 |
| 6.2.1 | The application [Status]  | 32 |
| 6.2.1.1 | Status - Overview..... | 32 |

| | |
|---|-----------|
| 6.2.1.2 Status - *Device name n* | 32 |
| 6.2.2 The application [Driver View]  | 34 |
| 6.2.2.1 Driver View – Function keys | 34 |
| 6.2.2.2 Driver View – Marker list | 34 |
| 6.2.2.3 Driver View – Notifications | 35 |
| 6.2.2.4 Driver View – Test drive | 36 |
| 6.2.2.5 Driver View – Shutdown | 37 |
| 6.2.3 The application [Busload]  | 38 |
| 6.2.3.1 Busload - CAN/Serial/LIN/Ethernet/Camera/CCP_XCP | 38 |
| 6.2.3.2 Busload - MOST150 | 39 |
| 6.2.3.3 Busload - GPS | 40 |
| 6.2.4 The application [Settings]  | 41 |
| 6.2.4.1 Settings - General | 41 |
| 6.2.4.2 Settings – Orientation | 43 |
| 6.2.5 The application [TSA Monitor]  | 44 |
| 6.2.6 The application [Camera Viewer]  | 45 |
| 6.3 Display | 47 |
| 6.3.1 Device status | 48 |
| 6.3.1.1 Memory full | 48 |
| 6.4 Other views | 50 |
| 6.4.1 AlertDialog | 50 |
| 6.4.2 FW-Update | 50 |
| 6.4.3 Launcher | 51 |
| 6.4.4 RC Monitor | 51 |
| 6.4.5 RC Text | 53 |
| 6.4.6 Standby | 53 |
| 6.5 Restrictions of the RC Touch in stand-alone mode | 53 |
| 6.5.1 Remote Control Touch applications | 54 |
| 6.5.2 System Client applications | 54 |
| 7 Operation | 57 |
| 7.1 Switching the device on | 57 |
| 7.2 Switching the device off | 57 |
| 7.3 Scrolling through applications | 57 |
| 7.4 Changing application | 57 |
| 7.5 Actuating functionkey | 58 |
| 7.6 Adjusting backlight | 58 |
| 7.6.1 Automatic adjustment | 58 |
| 7.6.2 Manual adjustment | 58 |
| 7.7 Adjusting volume | 58 |
| 7.8 Changing tab sheet | 59 |
| 7.9 Opening and closing side menu | 59 |
| 7.10 Setting marker  /  /  | 59 |
| 7.10.1 Marker with voice note  | 61 |
| 7.10.2 Marker without voice note  | 62 |
| 7.11 Playing voice note | 63 |
| 7.12 Scrolling through tab sheet | 63 |
| 7.13 Scrolling through tab bar | 63 |

| | |
|--|-----------|
| 7.14 Updating firmware  | 64 |
| 8 Maintenance provisions, safety regulations and Regulatory Information | 67 |
| 8.1 Regulatory Information only for the Remote Control Touch | 69 |
| 9 Data sheet Remote Control Touch | 70 |
| 10 Data sheet BLUEPIRAT Remote | 71 |
| 11 Adapter cables & pinning | 73 |
| 11.1 Remote Control Touch Power supply | 73 |
| 11.1.1 Remote Control Touch Pinout of connector | 73 |
| 11.1.2 Contacts of the Remote Control Touch connection | 73 |
| 11.2 BLUEPIRAT Remote Power supply including cable set | 74 |
| 11.2.1 BLUEPIRAT Remote Pinout of connector | 74 |
| 11.3 RJ45 Ethernet connector | 75 |
| 12 Support | 76 |
| 12.1 Service Center | 76 |
| 12.2 OTRS Ticket system | 76 |
| 12.2.1 What is OTRS? | 77 |
| 12.2.2 Needed information in a ticket | 77 |
| 12.2.2.1 Ticket Checklist | 77 |
| 12.2.2.2 The points in detail | 78 |
| 12.2.3 Sending Inquiries | 79 |
| 12.2.4 Login and Initial Steps | 79 |
| 12.2.5 Adding Files | 79 |
| 12.2.6 Search Function | 80 |
| 12.2.7 Closing a ticket | 80 |
| 12.2.8 Contact | 80 |
| 12.3 Sending in defective devices | 81 |
| 12.3.1 Service report | 81 |
| 12.3.2 Shipping address | 81 |
| 12.3.3 Batteries: | 81 |
| 12.4 Release info – informed just in time | 82 |
| 13 Abbreviations | 83 |
| 14 List of figures | 85 |
| 15 List of tables | 87 |
| 16 Contact | 88 |

1 LICENSE AGREEMENT

Please read the license agreement of this license contract carefully, before you install the software. By the installation of the software you agree to the conditions of this license contract.

This software-license agreement, in the following called "license", contains all rights and restrictions for final users that regulate the use of the accompanying software, operating instructions and other documents, in the following called as "software".

1. This license contract is an agreement between licensor and licensee, who is being licensed to use the named software.
2. Licensee acknowledges that this is only a limited nonexclusive license. This means, that the licensee has no right to allocate sublicenses. Licensor is and remains the owner of all titles, rights and interests in the software.
3. The software is a copyright property of the MAGNA Telemotive GmbH. The program or parts of it may not be further licensed to third parts, rented, sold or be further marketed in any form without explicit written approval by MAGNA Telemotive GmbH. The user may neither change the software and their components, nor modify, nor redevelop or decompile otherwise in any form.
4. This software is subject to no warranty. This software is sold as is, without any warranty. If at any time, a user changes his system, we hold no responsibility to change our software to make it work again.
5. This license permits licensee to install the software on more than one computer system, as long as the software will not be used on more than one computer system simultaneously. Licensee will not make copies of the software or allow copies of the software to be made by others, unless authorized by this license agreement. Licensee may make copies of the software for backup purposes only. Licensee is not entitled to transmit or to transfer the software or its rights from this license agreement.
6. Licensor is not liable to licensee for any damages, including compensatory, special, incidental, exemplary, punitive or consequential damages, connected with or resulting from this license agreement or licensee's use of this software.
7. Licensee agrees to defend and indemnify licensor and hold licensor harmless from all claims, losses, damages, complaints or expenses connected with or resulting from licensee's business operations.
8. Licensor has the right to terminate this license agreement and licensee's right to use this software upon any material breach by licensee. The duration of the license contract is indefinitely determined.
9. Licensee agrees to return all copies of the software to licensor or to destroy them upon termination of the license contract.
10. This license agreement replaces and supersedes all prior negotiations, dealings and agreements between licensor and licensee regarding this software.
11. This license contract is subject to German law.
12. If a regulation of this license contract is void by law, the validity of the remaining regulations is not affected. If there is such a regulation it will be replaced by a valid, according to the legal regulations and enforceable regulation with similar intention and similar economic consequence.
13. The license contract is effective by delivery of the software of the licensor to the licensee and/or by usage of the software by the licensee. This license contract is also valid without licensor's signature.
14. The license automatically goes out if the licensee does not agree to the license regulations described here or offend against the license regulations of this license contract. With ending the license contract the licensee is obliged to extinguish or to destroy the software and all copies of it no matter if installed or stored on disk or to hand all of it back to MAGNA Telemotive GmbH.
15. The licensee is liable for all damages caused to the licensor by the violation of these license regulations.

2 PRODUCT LIABILITY

2.1 Terms and Conditions of Sale and Delivery

The General Terms and Conditions of Sale and Delivery of MAGNA Telemotive GmbH can be found on our website (<https://telemotive.magna.com>) under imprint.

2.2 Important operating instructions

Please note these important instructions about the handling of devices of MAGNA Telemotive GmbH!

There's a linux system running on the devices and sometimes when the device has a dirty shutdown due to a power break down or unplugging the power supply, the system is corrupt from this time. You know this situation from a PC, when you switch it off some times it maybe will not work any more or show you some mistakes.

In most cases this issue is caught up and repaired by the linux system we use, but sometimes it can happen that the system on the logger is damaged and there's no access to the device any more.

We are optimizing the handling of corrupted systems permanently and are integrating some new enhancements regarding this kind of issues with every new release to save the system. But we can't make the system for 100% save against these influences.

So please use always the provided mechanism for shutting down the device or the implemented standby function in which the device shutting down when no traffic is detected any more in an adjustable time.

3 Overview

This user guide describes the administration of the

- Remote Control Touch
- BLUEPIRAT Remote

of MAGNA Telemotive GmbH.

This user guide describes the configuration and usage of this feature. The general configuration is described in the user guides of the used data logger as well as the System Client, which is valid for all devices.

This document refers to **firmware version 05.00.01** and the **System Client** from **version 5.0.1**. Some features depending on model and feature license or may not be available in older versions.

Software updates and user guides for other, optional, licensed enhancements are available in our Service Center. (Please find the address under Contact at the last page.)

To ensure the most reliable operation of your system as possible, please make sure to use always current firmware and software versions.

[Index](#)

4 System requirements

The communication between bus systems and control units is monitored, and relevant data can be recorded very precisely with the data logger. The collected data are stored to the logger and can be downloaded via Ethernet to a PC.

Control Unit

You need a Windows based Laptop or PC to configure the devices by the **System Client**. It also allows to save the recorded data and to use them offline later.

System Client

Update, configure and read out your data loggers with System Client. Save time with central administration of your software products. System Client is your key to success for using all our products!

BLUEPIRAT Rapid

High-performance multi-bus data logger for modern vehicle architectures based on Automotive Ethernet. With up to 3 TB internal memory and supreme recording performance. Robust and compact for in-vehicle use.

Due to the increasing complexity of driver assistance systems and the growing number of infotainment applications, the data traffic between ECUs in the most recent vehicle models has grown significantly. Consequently, besides the various classic bus systems, modern vehicle architectures are based on Automotive Ethernet according to BroadR-Reach / IEEE 802.3 100(0)Base-T1, which can keep up with the growing bandwidth demand.

BLUEPIRAT Mini / BLUEPIRAT2 / BLUEPIRAT2 5E

The **BLUEPIRAT Mini** is smallest data logger in the world with an outstanding functional scope. It offers a wide range of interfaces, stable temperature behavior, very low energy consumption, four GBit Ethernet ports, and much more. Different blue PiraT Mini can be expanded flexibly to one cluster and therefore handled very easily by using [System Link](#).

The **BLUEPIRAT2** is our top-class all-in-one data logger. Seven models cover a wide range of interfaces. (Device is EOL)

Additionally, the **BLUEPIRAT2 5E** offers improved power management and power backup, five integrated Ethernet ports and super-fast start-up behavior. The BLUEPIRAT2 can be expanded flexibly via [System Link](#). (Device is EOL)

Remote Control Touch (optional)

Operate your BLUEPIRAT data loggers safely and comfortably from the driver's or passenger seat. Via System Link our new remote control becomes part of your logger network. One remote control can handle all connected loggers.

BLUEPIRAT Remote (optional)

While Remote Control Touch is just a control unit for handling unique devices or a TSL network, the blue PiraT Remote additional has logger functionality by offering internal storage and some interfaces. (Device is EOL)

License

For some additional features an installed license is required. Settings for licensed features can be performed with a valid license only.

If you need a license for your logger, please contact our sales department (please find the address under contact at the last page).

4.1 Further manuals

Beside this user Manual, we offer the main manuals for our System Client as well as for the different data logger generations in our Service Center at

<https://sc.telemotive.de/bluepirat>.

Our licensed enhancements have own manuals which are stored in the Service Center too. You will find a list of these enhancements in the user manuals in the chapter **Additional features by optional licenses**.

Under the following links, you always will find the latest versions:

User manual for the System Client

https://sc.telemotive.de/4/uploads/media/SystemClient_UserManual.pdf

User manual for BLUEPIRAT Rapid

https://sc.telemotive.de/4/uploads/media/BLUEPIRAT_Rapid_UserManual.pdf

User manual for BLUEPIRAT Mini

https://sc.telemotive.de/4/uploads/media/BLUEPIRAT_Mini_UserManual.pdf

User manual for Remote Control Touch

https://sc.telemotive.de/4/uploads/media/RCTouch_UserGuide.pdf

User manual for BLUEPIRAT Power Backup

https://sc.telemotive.de/4/uploads/media/BLUEPIRAT_Power_Backup_UserManual.pdf

User manual for BLUEPIRAT2 / BLUEPIRAT2 5E

https://sc.telemotive.de/4/uploads/media/BLUEPIRAT2_UserManual.pdf

User manual for BLUEPIRAT Remote

https://sc.telemotive.de/4/uploads/media/BLUEPIRAT_Remote_UserGuide.pdf

For having an easy access if necessary, the most important manuals are linked in the client under the menu item [Help] and are reachable easily from there.

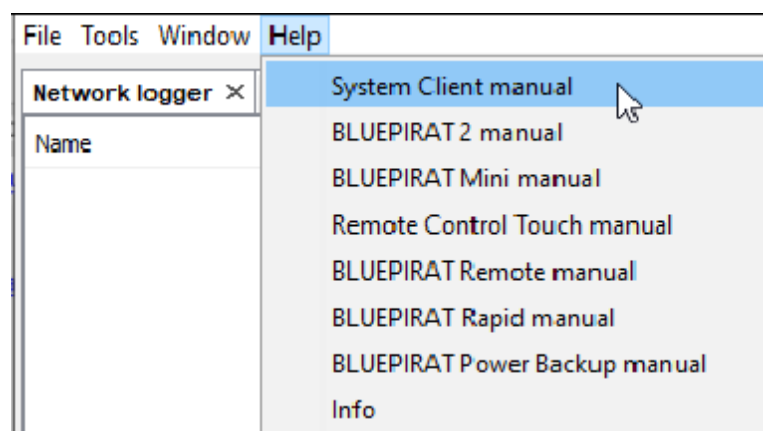

Figure 4.1: links to the manuals in the System Client

4.2 Additional features by optional licenses

Additional features can be activated by purchasing and installing licenses. Licenses can be ordered at our sales team. You find the user guides for these additional features in our Service Center. Currently the following licensed features are available.

| Feature | Description |
|------------------------------|---|
| Camera Link | video recording via video server or network cameras Till now, only some cameras from AXIS were supported |
| WLAN | supporting wireless LAN / WiFi (802.11, 802.11a, 802.11n), (802.11ac from FW 02.04.01) |
| GPS logging | tracking of GPS data |
| Measurements with CCP | CAN Calibration Protocol |
| Measurements with XCP | Universal Measurement and Calibration Protocol Currently the functionality for Ethernet (XCP on Ethernet) and the CAN-bus (XCP on CAN) are available. |
| MOST150 Streaming | logging MOST150 synchronous/isochronous data |
| MLBevo / QXDM | The license Connected-Gateway MLBevo enables the recording of data of the ATOP control unit MLBevo via USB to the Magna Telemotive data logger and convert these data with the System Client. (from FW 02.03.01) Additional this license allows to log Qualcomm QXDM logs via USB (from FW 03.06.XX) |
| Download Terminal | The in the System Client integrated Download Terminal allows an automatization of configured tasks for a defined group of devices. (from FW 02.03.01) |
| Test automation | Interface for connecting to test automation tools. At the moment, the sending of CAN messages is supported. (from FW 02.04.01) |
| Cellular network | Allows the logger to send status messages over cellular network. (from FW 03.01.01) |
| Firmware Care | As part of the " Service Product Firmware Care ", new software and firmware versions are made available for download for a limited period of time. This service is available for 12 months from the date of purchasing the BLUEPIRAT . This period can be extended by licenses. |

Table 4.1: Additional features by optional licenses

4.3 Firmware Care

MAGNA Telemotive GmbH invests a great amount in the further development of its products.

For this we regularly provide new functions and enhancements via firmware and client releases.

Basic conditions

As part of the " Service Product Firmware Care ", new software and firmware versions are made available for download for a limited period of time. This service is available for 12 months from the date of purchasing the **BLUEPIRAT**. This period can be extended.

For details, please contact your sales partner (see contact at the end of the manual for addresses).

Affected products

- **BLUEPIRAT Rapid**
- **BLUEPIRAT Mini**
- **Remote Control Touch**
- **BLUEPIRAT2 5E**
- **BLUEPIRAT2**
- **BLUEPIRAT Remote**

Note:

Enhancements are only possible in current firmware releases.

Attention:

Please note that updates to main firmware versions (05.00.01 / 06.00.01) need a special update license and can't be flashed to a device without this license.

To buy these licenses please contact our sales department under TMO.Sales@magna.com (please find the complete address under Contact on the last page).

5 Remote Control Touch / BLUEPIRAT Remote – hardware

This chapter describes the hardware of the **Remote Control Touch** and **BLUEPIRAT Remote**. The position and function of all interfaces, the accessories and the installation of hard- and software are explained.

The **Remote Control Touch** is the remote control and external display device for the BLUEPIRAT Mini and BLUEPIRAT2 data loggers or a TSL network.

The Remote Control Touch allows you to:

- display bus load, status and memory of available interfaces,
- display date and time,
- trigger functionkeys,
- display set markers,
- adjust backlight and volume,
- set triggers,
- record and play voice notes.

The **BLUEPIRAT Remote** has additional some interfaces and internal storage for logging data and can therefore be used as stand alone device.

5.1 Position of connectors and operating elements

5.1.1 Top view

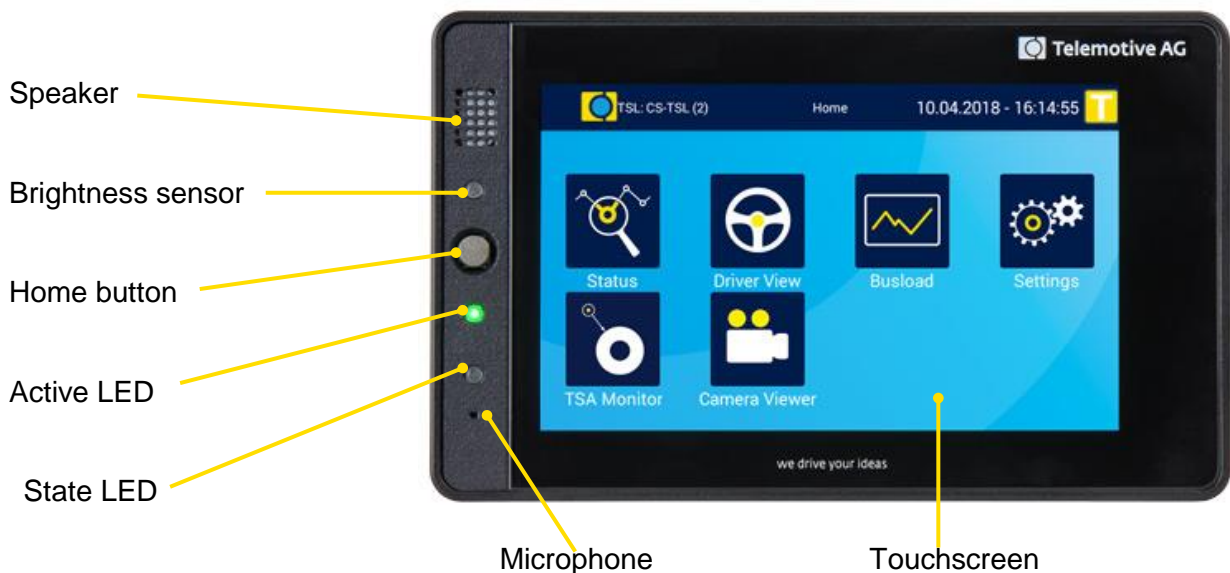
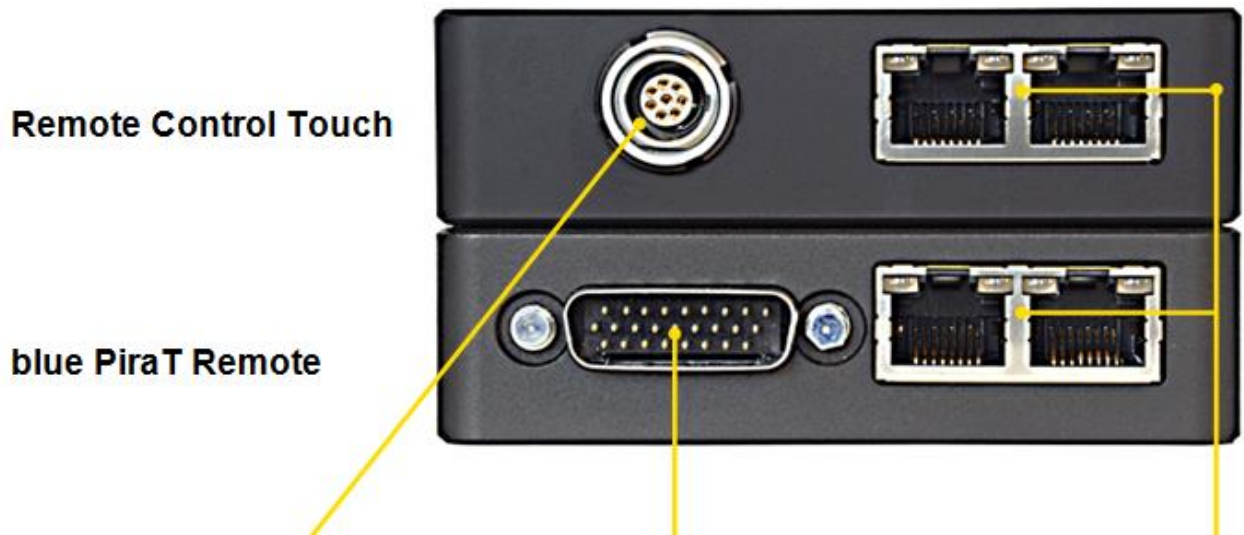

Figure 5.1: Top view with operating elements

[Index](#)

5.1.2 Side view, from the right



- 1 8-pol LEMO socket (RCT) 2 26 pol SUB-D (bPR) 3 2x Gbit Ethernet (RJ45)

Figure 5.2: Side view, from the right with connectors

5.1.3 Rear side

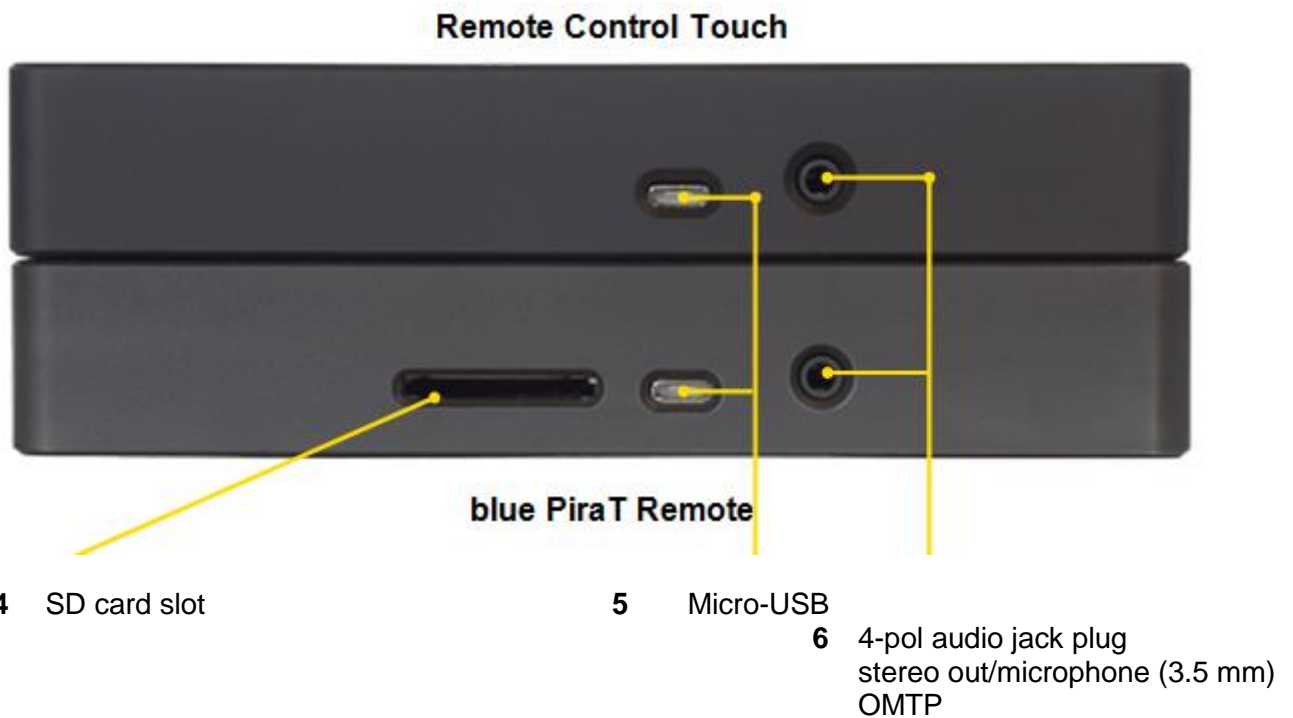

- 4 SD card slot 5 Micro-USB 6 4-pol audio jack plug
 stereo out/microphone (3.5 mm)
 OMTP

Figure 5.3: Rear side view with connectors

5.2 Functionality of connectors and operating elements

The functionality of connectors and operating elements is impaired by certain conditions such as moisture, darkness, heat or cold, mechanical action, dirt or similar.

Observe therefore the points described in chapter 8 Maintenance provisions, safety regulations.

5.2.1 Ports

The ports are used to connecting the devices, for example with the power supply.

| Port | | Cable | Connection with ... |
|------|--|--|------------------------------------|
| No. | Designation | | |
| 1 | 8-pol LEMO socket (<i>RCTouch only</i>) | Power cable with LEMO connector to banana plug | Power source |
| 2 | 26 pol SUB-D (<i>bP Remote only</i>) | | Power source interfaces |
| 3 | 2x Gbit Ethernet (RJ45) | Gbit Ethernet cable | Client computer or data logger |
| 4 | SD card slot (<i>bP Remote only</i>) | | Logging data |
| 5 | Micro-USB 2.0 | Micro-USB connecting cable | USB devices |
| 6 | 4-pol audio jack plug stereo out/microphone (3.5 mm) OMTP (CTIA does NOT work!) | 3.5" jack/audio cable | Microphone, speaker, headset, etc. |

Table 5.1: Available connections

5.2.2 Brightness sensor

The brightness sensor helps adjust the screen's backlight depending on the ambient light. It serves only the automatic regulation and is permanently active, for switching the display if necessary.

5.2.2.1 Night mode

If the environment is too dark, the devices automatically switches into night mode. In this view, the surface is displayed in modified colors, so that the driver is not blinded. The night mode will be activated if you drive into a tunnel for example.

5.2.3 Home button

The Home button is used to:

- switching the device on or off,
- switching to the **[Home]** screen

5.2.4 Speaker

The speaker is used to play voice notes. Its volume is adjustable.

5.2.5 LEDs

Activity and operating state of the **Remote Control Touch** and **BLUEPIRAT Remote** are indicated by the LEDs.

| Activity / operating state | Behavior | |
|--|----------------|-----------------------------------|
| | Active LED | State LED |
| device goes to standby | green pulsing | not lighted |
| in error mode | green light | red light |
| in operation | green light | not lighted |
| powered off | not lighted | not lighted |
| press Home button | brief light-up | not lighted |
| record voice note | brief light-up | red pulsing, as long as recording |
| set trigger | brief light-up | not lighted |
| switch off device | green pulsing | not lighted |
| switch on device | green flashing | not lighted |
| update firmware | green light | red light |
| wake up device | brief light-up | brief light-up |
| external medium detected (only BLUEPIRAT Re- mote) | green light | red flashing |
| External medium full | green light | red pulsing |

Table 5.2: LED behavior

5.2.6 Microphone

The microphone is used to record voice notes on triggers. The quality of the voice recording depends on the ambient environment .

5.2.7 Touchscreen

The screen is used to operate the devices. Only use the tip of the finger to operate it. The brightness is adjustable.

5.2.8 Micro-USB port

The Micro-USB port can be used in the host-mode.

It can be used for logging data to an external storage (BLUEPIRAT Remote only!) or for connecting a GPS, mobile phone or Wi-Fi module to the logger. Wi-Fi can be used to get access to the logger over the client or to use the feature **Live View**.

5.2.8.1 USB storage (at BLUEPIRAT Remote only):

The USB storage has to be formatted in the FAT32, NTFS or ext4 file format. You could connect USB flash drives and external hard drive up to a maximal supply current of 500 mA. External power supplies must not be connected to the hard disk.

If the USB memory is pulled in the operational state, the following problems exists:

- The logger is in an undefined state and will not record any data. Only after rebooting the device behaves as expected.
- The data on the USB memory can then be unreadable when it is removed during a write operation.

If you turn off the BLUEPIRAT Remote with the **[ON / Trigger]** button, you have 5 seconds to remove the medium before the logger can be reawakened.

Note:

MAGNA Telemotive GmbH recommends the testing of every external storage before using it in a measurement. We suggest that especially USB devices with USB 3.0 are sometimes not recognized by the system.

5.2.9 SD card slot (BLUEPIRAT Remote only)

The **BLUEPIRAT Remote** offers the possibility to store data parallel to a removable media as SD card or USB device. The configuration of this feature is described in the System Client user guide.

Requirements:

| | |
|------------------|---|
| Size | At least 4 GB (or a partition at least with this size) |
| Free memory | At least 3 GB for the circular buffer (only for parallel recording) |
| File system | FAT32, NTFS or ext4 |
| Write protection | unlocked |

The following SD cards have been tested with the Telemotive data loggers and released for use:

| Manufacturer | Description | Size | Type |
|--------------|------------------------|-------|------|
| SanDisk | Extreme PRO | 64 GB | SDXC |
| Transcend | Ultimate Speed | 16 GB | SDHC |
| Transcend | Ultimate Speed | 32 GB | SDHC |
| Transcend | Ultimate Speed | 64 GB | SDXC |
| Kingston | SDA3 | 16 GB | SDHC |
| Kingston | SD10VG2 | 32 GB | SDHC |
| Intenso | 3431470 | 32 GB | SDHC |
| Intenso | 3431490 Professional | 64 GB | SDXC |
| Hama | Class 10 45 Mbps | 16 GB | SDHC |
| Hama | Class 10 45 Mbps | 64 GB | SDXC |
| Extrememory | Performance Class 6 | 16 GB | SDHC |
| Extrememory | HyPerformance Class 10 | 32 GB | SDHC |
| SanDisk | Extreme | 32 GB | SDHC |

Table 5.3: Compatible SD cards

If the removable media is detected by the logger, the red State LED starts flashing.

A write-protected SD memory card will be indicated by the permanent illumination of the red STATE LED.

In addition, the write protection will be highlighted in the network logger window of the System Client with a red labelled exclamation mark and an entry in the bug report "FC_MS_READ_ONLY" with a corresponding note.

Then shut down the bP Mini, unlock the SD card, reinsert it and reboot the device.

Attention:

Removing the SD card without prior shutdown may result in the loss of all recorded data.

If the SD card is pulled in the operational state, the following problems exist:

- The logger is in an undefined state and will not record any data. Only after rebooting the device behaves as expected.
- The data on the SD card can then be unreadable when the SD card is removed during a write operation.

If you turn off the BLUEPIRAT Remote with the **[ON / Trigger]** button, you have 5 seconds to remove the disk before the logger can be reawakened.

Please find more hints for using the SD card in the manual of the System Client.

5.3 Accessories

The **Remote Control Touch** is supplied with a power cable with LEMO connector to banana plug (length: ~ 1,5 m).

The **BLUEPIRAT Remote** is connected by a 26-pol SUB-D connector to the device and has the cables for the available interfaces integrated in the cable set.

Additional accessories are available for purchase. The following accessories are compatible:

- mounting bracket
- various adapter cables

Please contact our sales department for more information about the accessories.

5.4 Installation

The **Remote Control Touch** and **BLUEPIRAT Remote** require a connection to the power supply and one to the client computer.

In order to make full use of all functions of the Remote Control Touch, a connection to at least one BLUEPIRAT data logger is required. This creates a **System Link (TSL)**.

Find more information about client and TSL in the **User manual for the System Client**.

5.4.1 Cable connection

Note:

Connect the Remote Control Touch and BLUEPIRAT Remote only with devices of MAGNA Telemotive GmbH (BLUEPIRAT2, BLUEPIRAT Mini, Remote Control).

Note:

Make sure that the devices are switched off before disconnecting it from power supply.

5.4.1.1 In the network

The **Remote Control Touch / BLUEPIRAT Remote** has two Ethernet ports. The loggers to be controlled are connected directly via Ethernet. These loggers must establish a TSL network with the Remote Control Touch / BLUEPIRAT Remote in order to be recognized. The client computer can be connected to a free Ethernet port of the TSL chain.

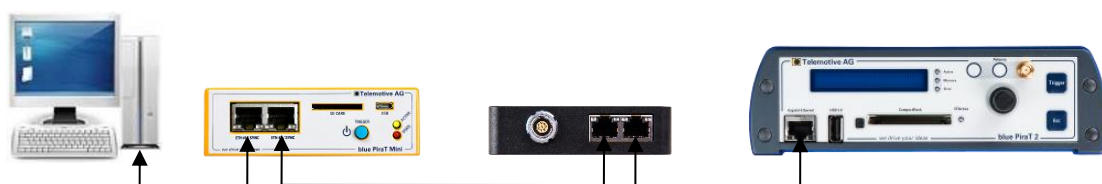

Figure 5.4: TSL network with one bPMini, one RCT and one bP2 (e.g.)

5.5 Download and installation of the System Client

Open your internet browser and enter the IP address of the logger

(Default settings: **Automatic DHCP configuration for TSL with IP 192.168.0.233**) and press **[Enter]**.

<http://192.168.0.233/client.html>

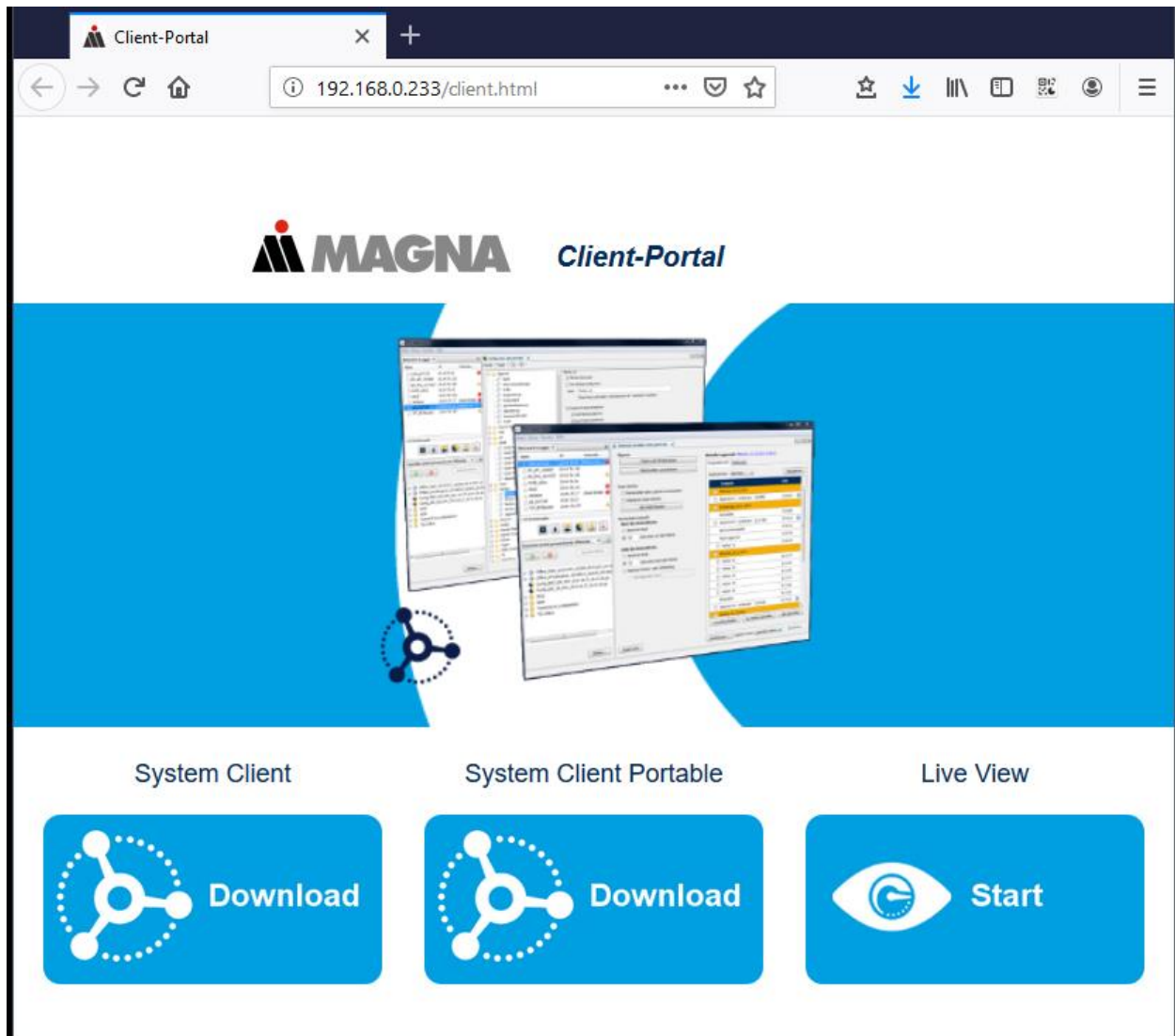

Figure 5.5: Client Portal

The connection between the logger and your computer system will be established. Please take care that the network settings of your network adapter are set to **Obtain IP address automatically**.

Click **[Download]**, to download the System Client (64 Bit) as portable or install version directly from the logger. The 32 Bit version is available in our service center.

The links are the same as these ones:

System Client: https://sc.telemotive.de/4/uploads/media/System_Client_Setup.zip

System Client portable: https://sc.telemotive.de/4/uploads/media/System_Client_Portable.zip

Follow these steps, depending on your browser:

| Browser | Proceeding |
|-------------------|--|
| Internet Explorer | Click [Save] , to locally save the file on your system. Click [Accomplish] . |
| Mozilla Firefox | Click [Save file] , to locally save the file on your system. Click the arrow on the right top of the browser menu and select the downloaded application in the appearing context menu. |

In the dialog that opens select the desired software language from the dropdown menu.
Click **[OK]**.

Follow the instructions in the next dialog and select an installation directory.
Click **[Install]**.

After successful installation you will find the **System Client** icon on your desktop. Double-click the icon to start the application.

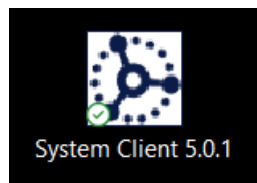

Figure 5.6: Desktop icon

5.6 System Client portable

The System Client is also available as a portable version which needs no installation but unpacking. This version is ready for downloading in our Service Center.

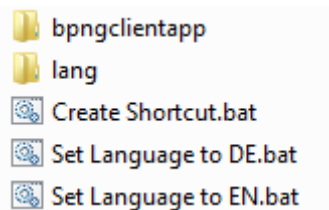

Figure 5.7: Content of the portable client

The portable version includes some batch files for these functions:

| | |
|-------------------------------|--|
| Create Shortcut.bat | creates a shortcut for the start file of the portable client |
| Set Language to DE.bat | changes the language into german |
| Set Language to EN.bat | changes the language into english (standard) |

5.7 Default network settings

Important:

The loggers default setting is *Automatic DHCP-configuration for TSL with IP 192.168.0.233*) and has to be connected by an Ethernet cable from „ETH #1 / TSL“ or „ETH #2 / TSL“ to your computer system.

⇒ <http://192.168.0.233>

5.8 Terminal IP address

Each **BLUEPIRAT** has an additional, permanently set network address internally, which can be used to reach the device if the set IP address cannot be reached. This address can also be used if several devices have the same IP setting. For this feature every data logger has a second, fixed IP address in the subnet 10.1.X.Y which can be contacted by the System Client.

Each terminal IP address is unique!

These additional IP addresses are all located in subnet 10.1.X.Y. The system client can access the devices via this IP address

Attention:

To use this option your computers network port has to be set to the fixed IP address 10.1.255.254 and subnet mask 255.255.0.0.

To set this IP address, please go to the specific network connection at **[Properties]** change the IP settings and close the window with **[OK]**.

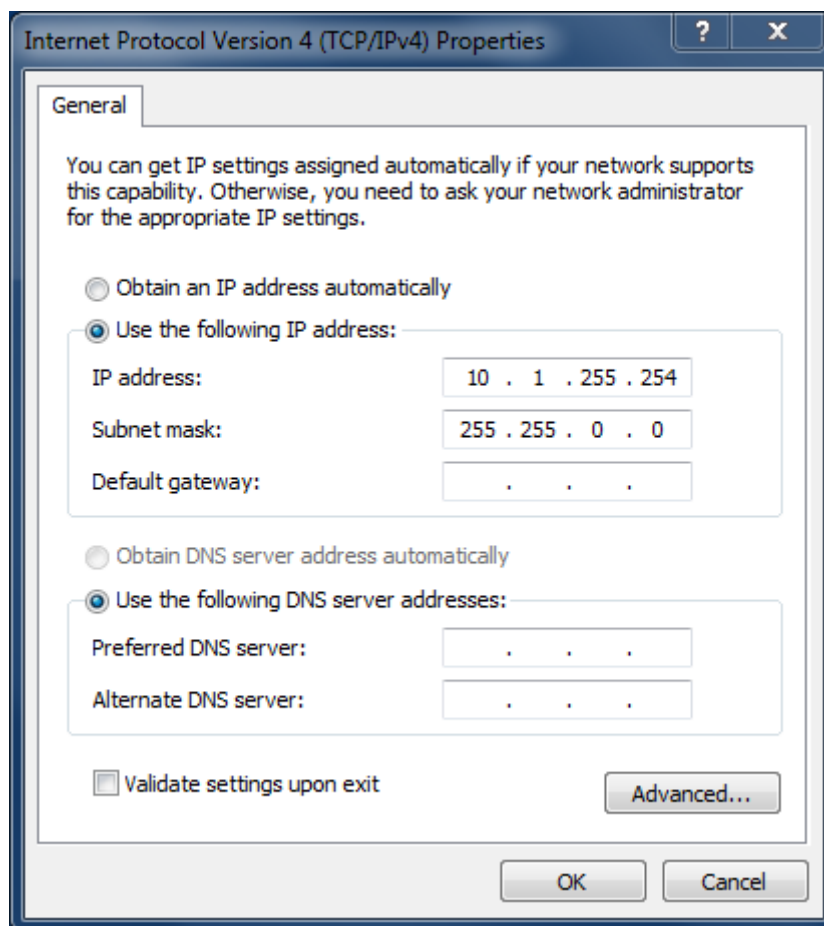

Figure 5.8: Change IP settings

If this is given, the system client finds the devices on the alternative IP address and displays them in the network logger list with the terminal IP address. From then on the devices can be used as usual. This allows the loggers to be read out simultaneously without having to operate them as a DHCP client or change the IP settings on each logger.

5.9 Connecting the RCTouch / bP Remote with a data logger

5.9.1 Configure the network settings

All Telemotive devices are configured as **Automatic DHCP configuration for TSL with IP 192.168.0.233** by default:

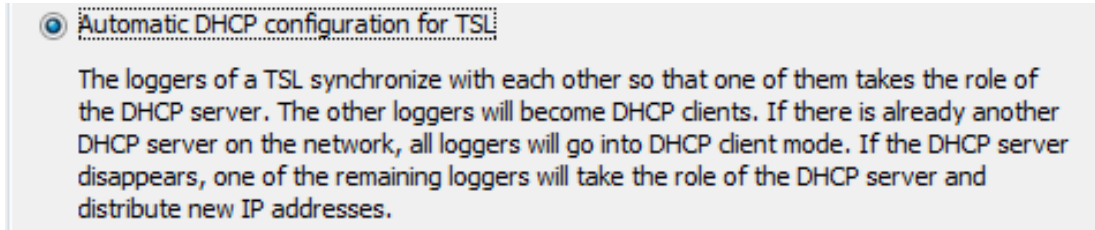

Figure 5.9: Automatic DHCP configuration for TSL

So the Network settings have NOT to be modified!

If your environment needs other network settings. You can modify them by yourself.

You can read in the **System Client manual** at (**Network settings**) how to set up the network. You can find the manual in the Client under the menu item [**Help**].

In our example we configured the **Remote Control Touch / BLUEPIRAT Remote** as DHCP-Client and connected it with the data logger (**see chapter 5.4.1.2**). In the next picture you can see the two devices in the client. The device with the IP address 192.168.0.233 is the data logger, because it is set up as DHCP-Server. In the **System Client manual (Name)** you can see how to give names for the devices. This might be helpful for better clarity.

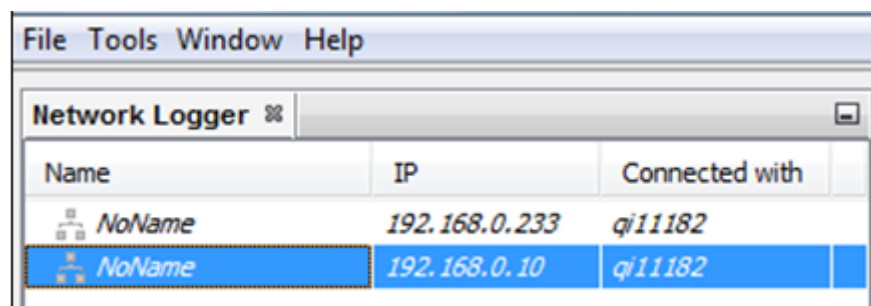

| Name | IP | Connected with |
|--------|---------------|----------------|
| NoName | 192.168.0.233 | qi11182 |
| NoName | 192.168.0.10 | qi11182 |

Figure 5.10: Viewing the devices in the client

5.9.2 Activating System Link (TSL)

In the delivery status and as default values TSL is just activated!

But for sure you can modify these settings at these devices by yourself:

You can activate it by clicking **[TSL active]** like you can see in the following picture. In the **System Client manual (Establishing and configuring a TSL network)** you can find more details about TSL.

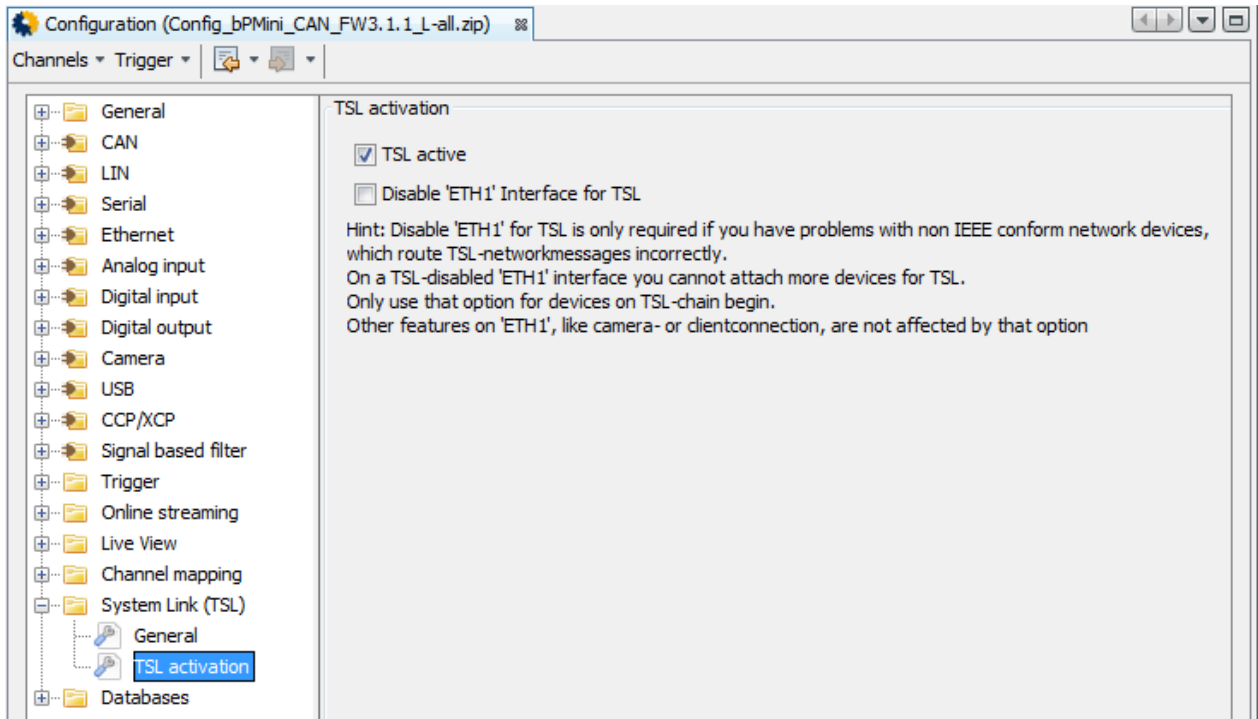

Figure 5.11: Activating TSL

If TSL is active at both devices, they are shown as TSL cluster in the client. You can use the RCT with the data logger now.

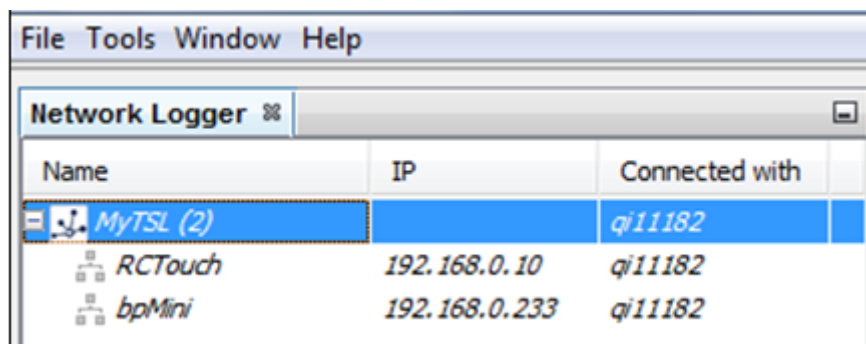

Figure 5.12: Representation of the TSL cluster in the client

5.10 Resetting the network settings

Note:

Due to a wrong network setting it may be impossible to reach the data logger any more. In this case the network configuration can be resetted by a long press on the [ON / Trigger] button to default settings: => Automatic DHCP configuration for TSL with IP 192.168.0.233

Switch off the device

Press the home button.

- Active-LED and State-LED are blinking once. Active-LED is blinking green.

Press and hold the home button for about 20 sec. until the state LED is blinking 2 times.

- State-LED is blinking 2 times
- Active-LED is lightning green.
- The network settings will be set back to default

Tipp on **[Accept]**.

- The warning popup disappears.
- Active-LED is blinking green.
- The display shows the launcher with a progress bar.
- A warning popup is shown.

Tipp on **[Accept]**.

- The warning popup disappears.

The Remote Control Touch / BLUEPIRAT Remote is ready when:

- The view **[Driver view]** is shown on the display and
- Active-LED is lightning green.

Afterwards the data logger can be reached again by using a direct connection with a PC/Laptop.

You'll find more information in the **System Client** manual

5.11 Wake up the Remote Control Touch over KI 15

In order to start the Remote Control Touch in a TSL network with the other devices, it can be waked up via KL 15.

We recommend the following configuration:

- On a device which is woken up via a data bus, the Initial value is set to 1 on a digital Output e.g. for **DigitalOut #2**. This means that it becomes active as soon as the logger starts up.

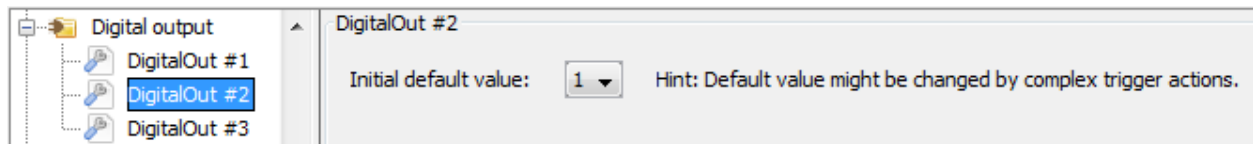

Figure 5.13: Setting DigitalOut #2 to 1

- The **DIG OUT #2 socket** of the logger is connected directly to the **KI 15 connector** of the **Remote Control Touch** and wakes it up.
- **KI 15** on the Remote Control Touch is configured to **[Wakeup on clamp 15]**.

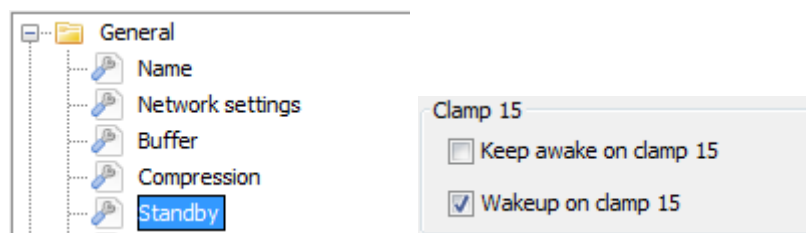

Figure 5.5.14: Wakeup on clamp 15

As long as a participant of the TSL network receives data via a channel for which [Keep awake on busload] is activated the TSL devices hold each other awake, therefore the option **[Keep awake on clamp 15]** should be deactivated here!

5.11.1 Configuration before firmware version 03.02.01

The possibility of configuring clamp 15 was implemented in firmware version 03.02.01 first, therefore a bypass solution is necessary for older firmware versions, since the connection is not permanently kept awake with clamp 15.

To do this, **DigitalOut #2** is set to **0** on the logger via a **complex trigger** as when the logger is started.

- New Trigger => [x] Trigger at message reception
- Complex event => Expression: $AI.1 > 10$
- Action: [set digital output] => Channel: DigitalOut #2 => Set to 0 (low)

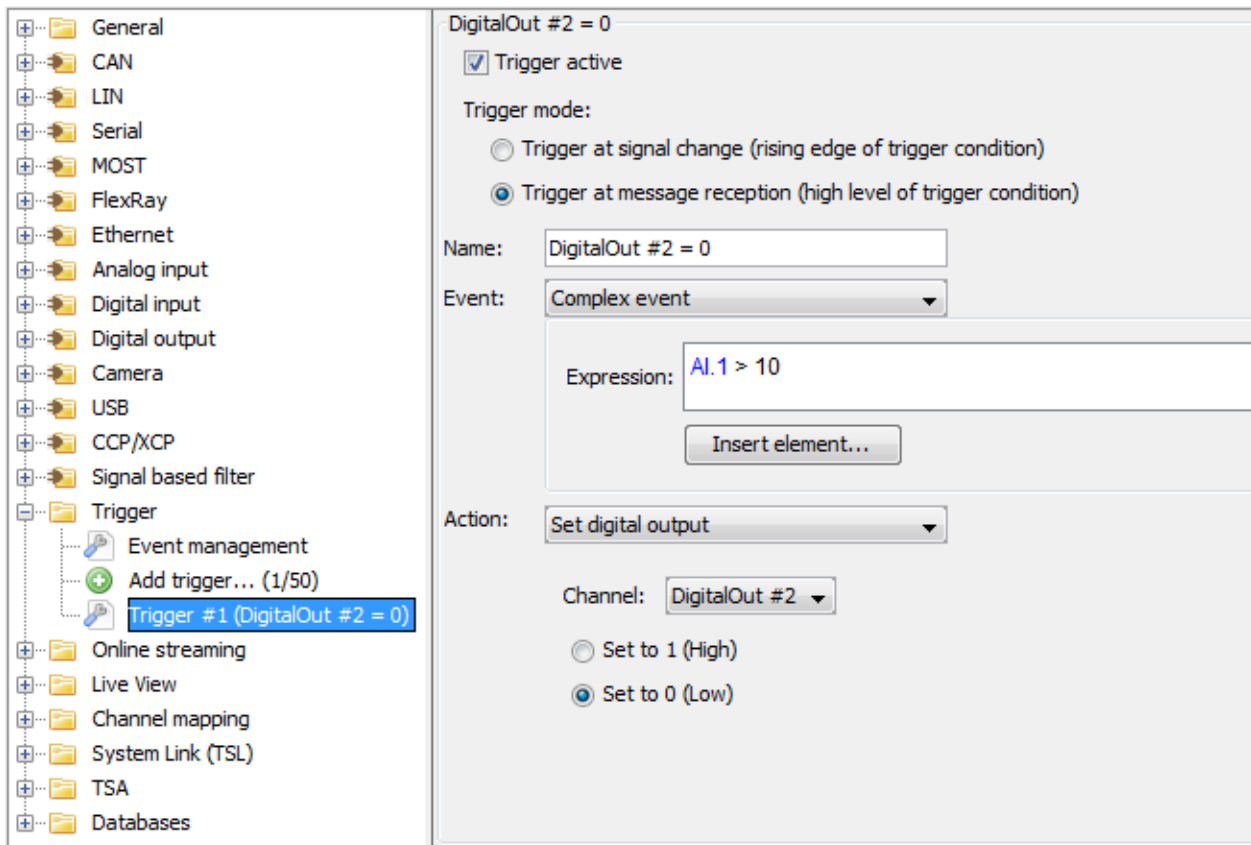

Figure 5.15: Resetting DigitalOut #2 to 0

Since **Analog #1** only measures the internal voltage, the event occurs as soon as the logger starts up and the voltage rises above 10 V ($AI1 > 10$). The triggers are only processed after a certain boot time of the logger, so that the signal at KL 15 is enough to wake up the Remote Control Touch before it is set to 0 again via the trigger, so that the devices are not kept permanently awake.

Attention: The sampling rate of the analog input must be set to 1000 ms or higher, otherwise the permanent queries via the trigger will cause a heavy load on the system!

Configuration => Analog input => General settings

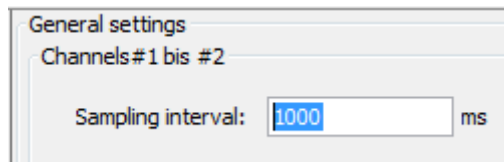

Figure 5.16: Sampling interval of Analog input #1

This workaround solution with the trigger is no longer necessary from firmware version 03.02.01!

6 User Interface

This chapter describes the application setup and the layout of the individual views as well as the windows inside.

The **Remote Control Touch / BLUEPIRAT Remote** software is very user-friendly thanks to its graphic surface and the clear outline.

The next figure shows the outline of the application in **<Home>** view and four applications. The application views contain minimum one tab. For the applications Driver View and Settings, the number and naming of the tabs is set.

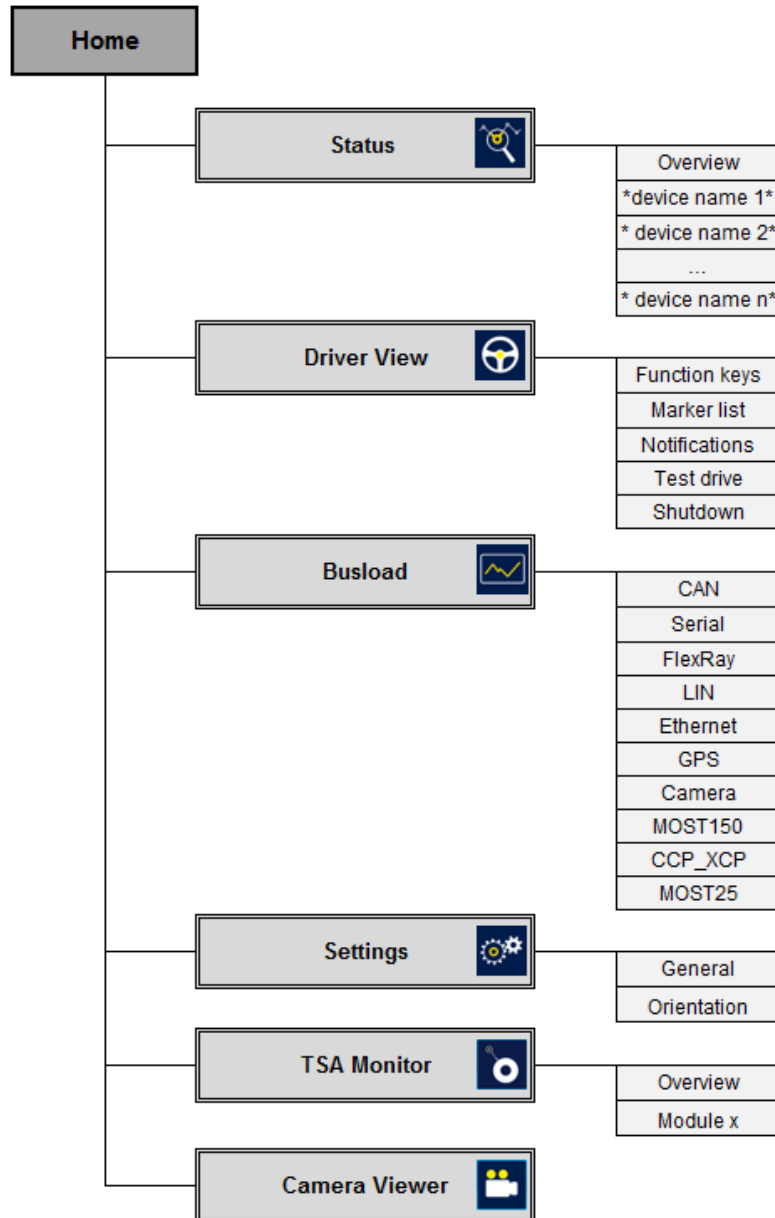

Figure 6.1: Application sitemap

Note: “n” stands for any number of devices

When an application is launched for the first time after switching on, the uppermost tab is shown. The next time you launch the application, the tab last opened is shown.

6.1 Layout of the views

All views consist of a window and a dark blue frame.

As the window contents vary depending on the view, they are described in more detail in the following sections of this chapter.

The dark blue frame contains in all views a header bar on top and, with the exception of the <Home> view, a tab bar at the bottom.

The screenshot shows the application interface with the following components:

- Header bar:** Contains a menu icon, the text "TSL: TSL_2_4 (4)", "Status", the date and time "29.06.2016 - 10:36:22", and a trigger button (yellow square with 'T').
- Window:** A table with the following data:

| Trigger Count: | | 8 | | |
|-------------------|---------------|--------|----------|--------------|
| Logger | IP | Status | Type | FW |
| RCT_2_4 | 192.168.0.90 | OK | RC Touch | 02.04.00.180 |
| bP2_WLAN | 192.168.0.233 | OK | bP2 | 02.04.00.180 |
| bPMini_LIN_DUT193 | 192.168.0.89 | OK | bP Mini | 02.04.00.180 |
- Tab bar:** Located at the bottom, showing "Overview" and other view names: "RCT_2_4", "bP2_WLAN", "bPMini_LIN_DUT193", "bPMini_FlexRay_DUT".

Header bar

Window

Tab bar

Figure 6.2: Components of the application views

6.1.1 Header bar

The header bar contains in each view:

- the labeling of the current view and



- date and time of the device or the TSL network.



- a trigger button



In the <Home> view:



Is located to the left the Telemotive logo.

In the application views, the header bar contains on the left:

- the button  respectively  for the side menu,
- the icon of the current application (see section 6.2) and



- the device name in standalone mode or “TSL: *name of the TSL* (*number of TSL members*)” in the TSL network.

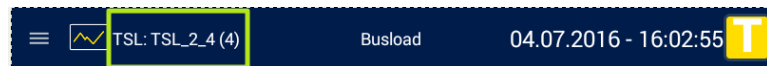

6.1.1.1 Warning messages

Here you see some samples of warnings, which are displayed on the top of the display.

When the available memory runs out of free capacity, a yellow warning is shown at the header bar at a filling level of 75 %.



From a filling level of 95 % the header bar shows a red error icon.



New trace data are still recorded, when the circular buffer is active but older data will be deleted part by part. For more information about the **circular buffer** please look at the manual of the System Client.



The warning is usually linked directly to the page on which the warning is then described in detail. If you tap on the title bar at the top in this example, the display changes directly to **[Driver View] => [Notifications]**, where a warning about the filling level of a TSL member is displayed.

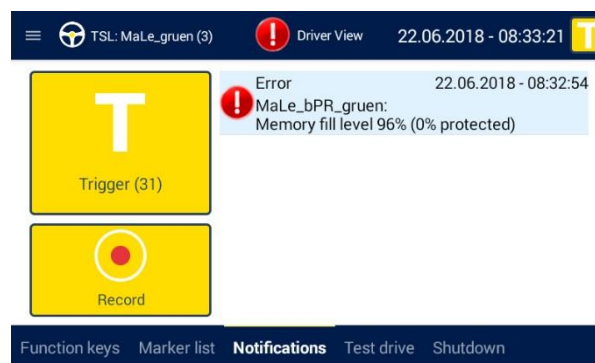

6.1.2 Side menu

Over the button  on the left of the header bar you can access the other applications.

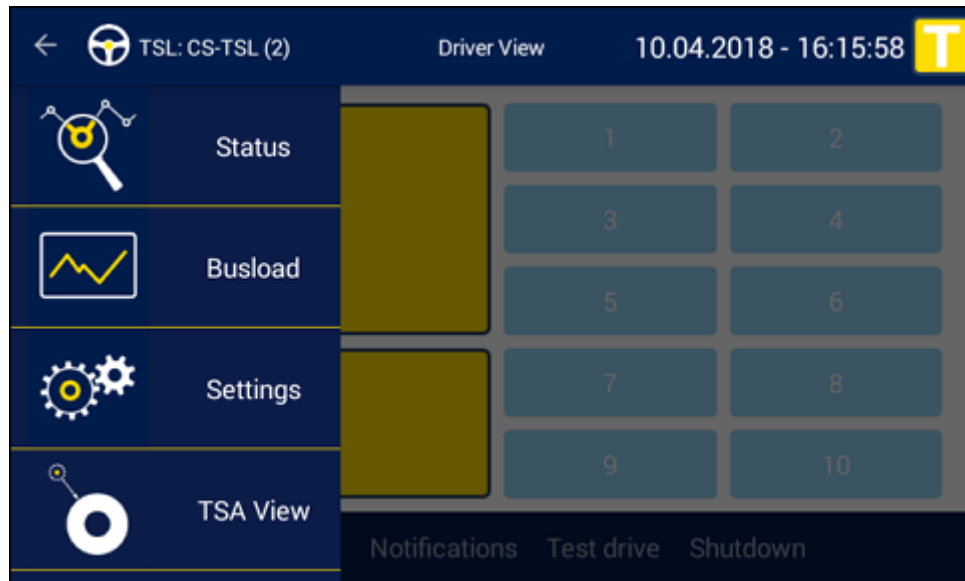

Figure 6.3: Unfolded page menu

- The side menu is closed by the following actions:
- Tap the arrow on the top left in the header bar
- Tap in the unfolded side menu
- Tap the area to the right of the unfolded side menu

6.1.3 Tab bar

In the application views, the tab bar contains minimum one tab. The tabs serve as shortcuts to the individual tab sheets. Inactive tabs contain the name of the tab sheet in blue letters, active tabs in white and bold. The active tab is further characterized by a narrow bright yellow margin above.



6.2 Applications |

An icon has been set for each of the applications to start them more easily. In the **[Home]** view and the side menu these icons serve as shortcuts to the applications and on the tab sheets they serve for orientation.

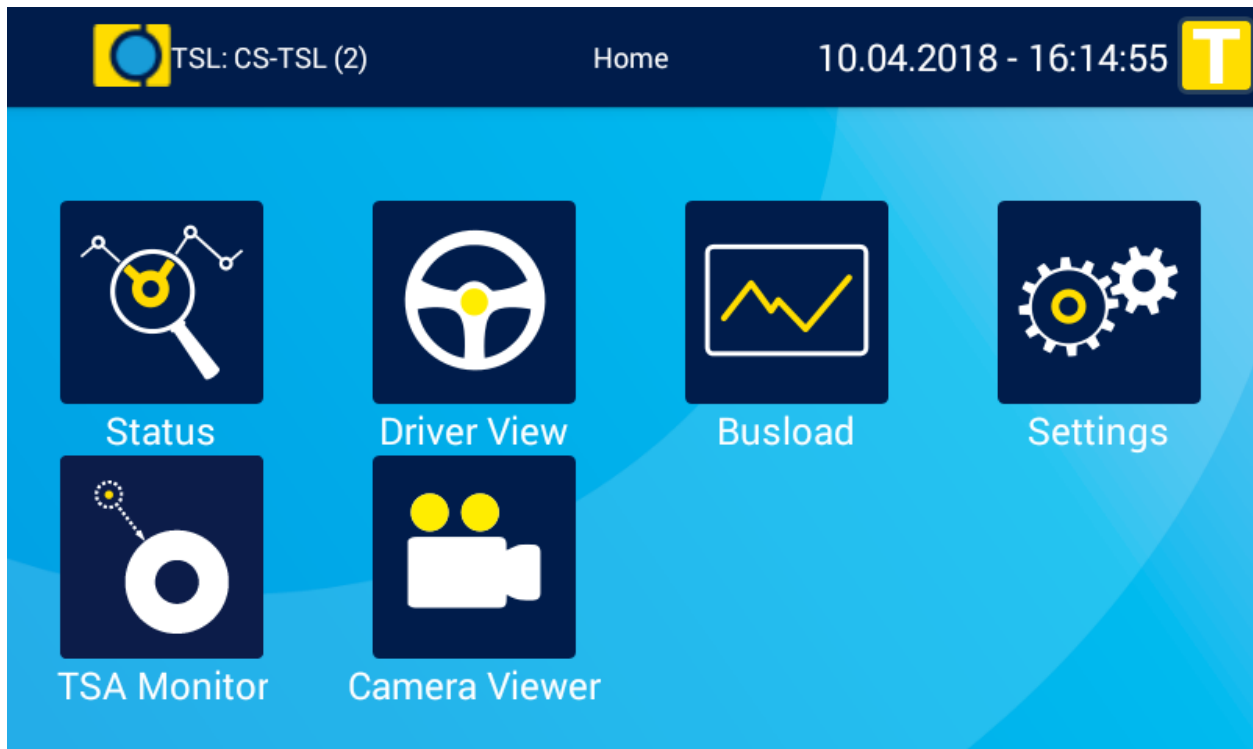

Figure 6.4: Home view







| Icon | Name | Function |
|---|---------------|--|
|  | Status | Display of information on the connected devices |
|  | Driver View | Management of the function keys, markers and voice notes |
|  | Busload | Display of all available buses and their channels |
|  | Settings | Adjustment of backlight and volume |
|  | TSA Monitor | Display of TSA modules <i>(from Release 3.2.1 Enh. 10869)</i> |
|  | Camera Viewer | Live view of an connected camera <i>(from Release 3.2.1 Enh.932)</i> |

Table 6.1: Application overview

6.2.1 The application [Status] |

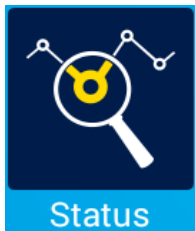

Display of information on the connected devices

The application **Status** contains minimum two tab sheets: the tab sheet **[Overview]** and the tab sheet of the Remote Control Touch / BLUEPI-RAT Remote with the name assigned in the System Client.

If more devices in a TSL network are connected, each device is assigned a tab sheet named after it.

6.2.1.1 Status - Overview

The window of the tab sheet **[Overview]** contains, apart from the trigger counter at <Trigger Count>, a tabular overview of all connected devices with the following information:

| Trigger Count: 3 | | | | |
|------------------|--------------|--------|----------|--------------|
| Logger | IP | Status | Type | FW |
| RCT | 10.64.76.204 | OK | RC Touch | 02.04.00.190 |
| bPMini_MOST150 | 10.64.76.173 | OK | bP Mini | 02.04.00.190 |

Gerätename IP-Adresse Gerätstatus Gerätetyp Firmwareversion

Overview RCT bPMini_MOST150

Figure 6.5: Tab sheet “Overview”

6.2.1.2 Status - *Device name n*

Note: “n” stands for any number of devices

Each device listed on the tab sheet **[Overview]** can be viewed separately on the respectively named tab sheet.

- 1 Device name
- 2 Configuration name
- 3 IP address and subnet mask

| TSL: CS_TSL (3) | | Status | 03.08.2016 - 10:11:15 | | T |
|-----------------|--|---------------|---|--|---|
| Logger: | 1 CS_bPR_1005740 | Config: | 2 default | | |
| Network: | 3 IP 192.168.0.233 Subnet 255.255.255.0 | 4 DHCP Server | 5 Terminal-IP 10.1.215.80 Subnet 255.255.0.0 | | |
| Memory: | 6 9 GB | 7 4% filled | 8 <1% protected | | |
| Status: | 9 OK | | 10 | | |

Overview CS_bPR_1005740 CS_bP2_1003696 CS_RCT_1006009

4 DHCP mode
5 Terminal IP address and subnet mask
6 Storage capacity
7 Memory percentage filled
8 Memory percentage protected
9 Device status
10 Error count

The window of these tab sheets, with the exception of the Remote Control Touch window, contains the following displays:

Figure 6.6: Tab sheet “*Device name n*”

Note:

The Remote Control Touch has no internal memory. The memory percentage filled and protected are therefore not shown on its tab sheet.

| TSL: MaLe_blaue (2) | | Status | 26.10.2017 - 14:05:17 | | T |
|---------------------|--|-----------------|---|--|---|
| Logger: | bPM_LIN_MaLe_3_2_1 | Config: | default | | |
| Network: | IP 10.23.224.176 Subnet 255.255.240.0 | TSL IP autoconf | Terminal-IP 10.1.205.17 Subnet 255.255.0.0 | | |
| Memory: | 51 GB | 100% filled | <1% protected | | |
| Status: | RING | | | | |

Overview bPM_LIN_MaLe_3_2_1 MaLe_RCT_blaue

Figure 6.7: Device status with error message when memory runs out of space

6.2.2 The application [Driver View] |



Management of the function keys, markers and voice notes

The application **Driver View** is used for setting triggers, recording voice notes or pressing the function keys. Further functions are overviews of existing markers and hints, administration of test drives and shutdown the TSL network.

6.2.2.1 Driver View – Function keys

The window of the tab sheet **[Function keys]** contains two buttons on the left and ten function keys on the right. The function keys can be assigned “complex triggers” (see **User manual for the System Client**). The name of the complex trigger is shown as text on the key.

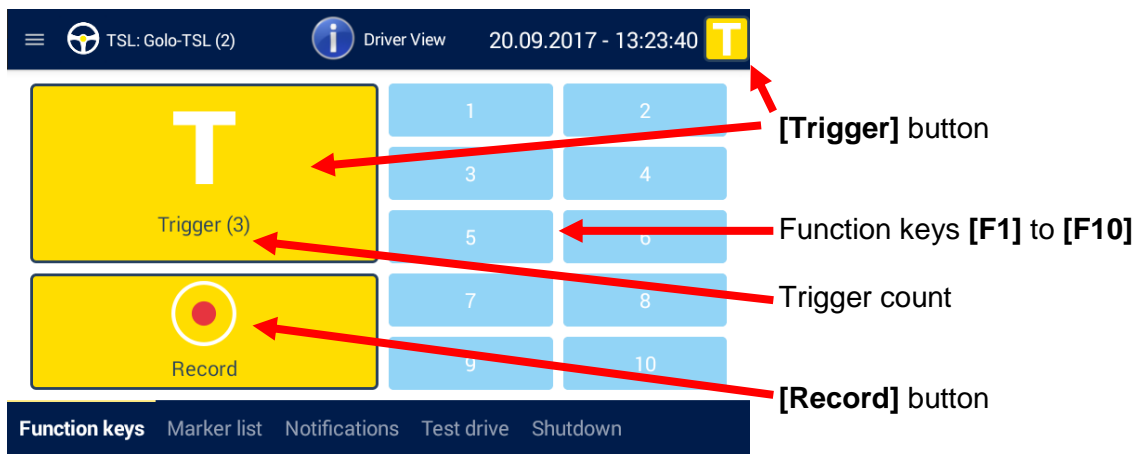



Figure 6.8: Tab sheet “Function keys”

6.2.2.2 Driver View – Marker list

The window of the tab sheet **[Marker list]** contains two buttons on the left and a list of set markers on the right. The markers are sorted by index and indicate date and time of the setting. A trigger that was set using the **[Record]** button contains a voice note. This is indicated by the  button in the marker entry.

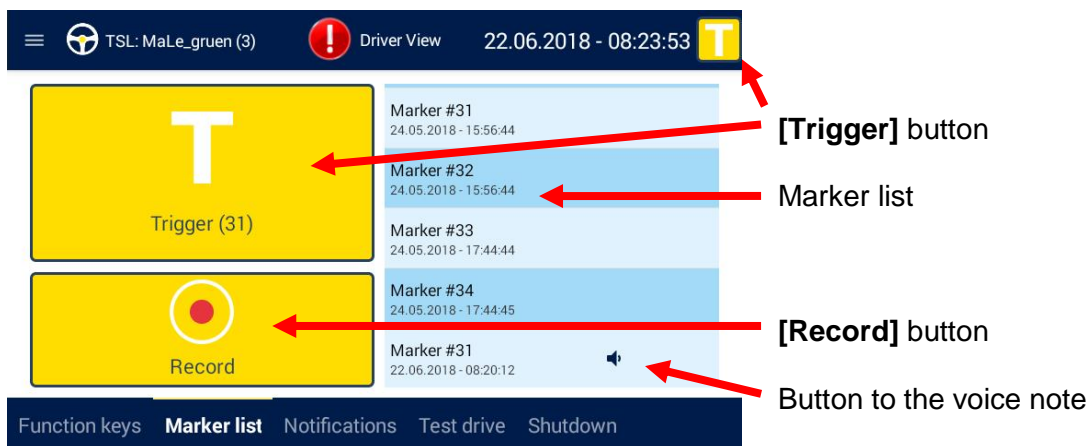

Figure 6.9: Tab sheet “Marker list”

6.2.2.3 Driver View – Notifications

The tab **[Notifications]** shows on the left side again the Trigger- and Record-button and on the right side some notifications. These can be as well actions which are initialised by the client as warnings and errors of the devices.

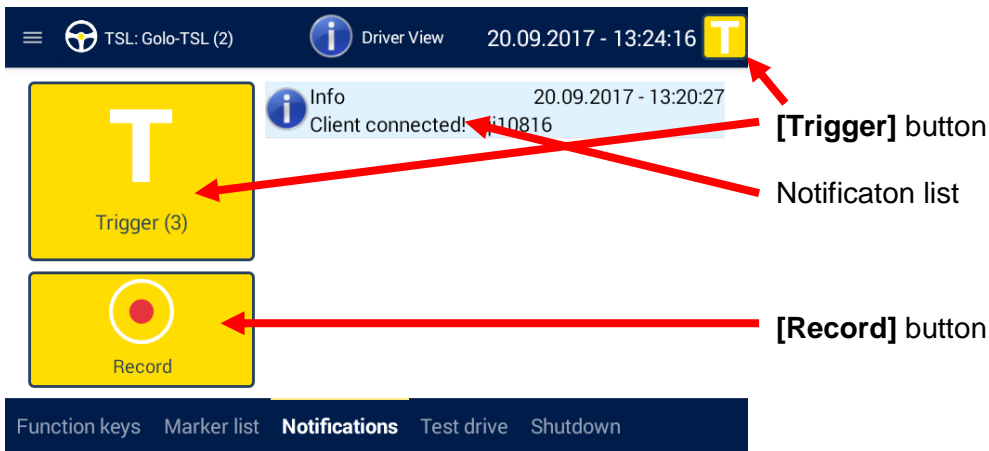

Figure 6.10: Tab sheet “Notifications”

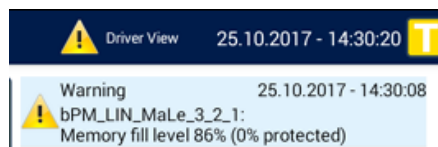

Figure 6.11: Tab sheet “Notifications”: Memory fill level from 75 %

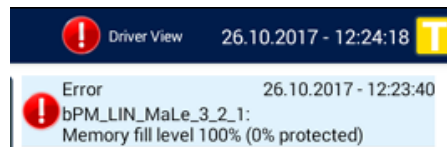

Figure 6.12: Tab sheet “Notifications”: Memory fill level from 95 %

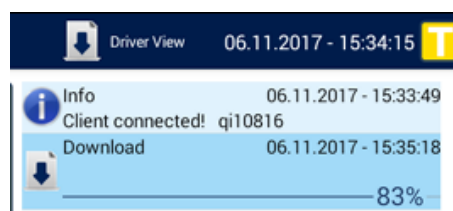

Figure 6.13: Tab sheet “Notifications”: Download

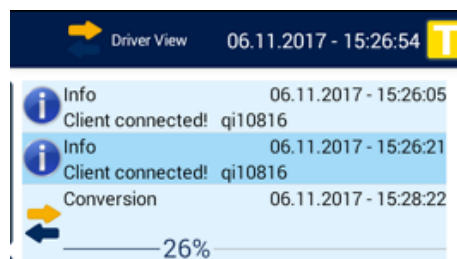

Figure 6.14: Tab sheet “Notifications”: Conversion

6.2.2.4 Driver View – Test drive

On the tab [Test drive] you can start test drives which can be analysed separately by the System Client.

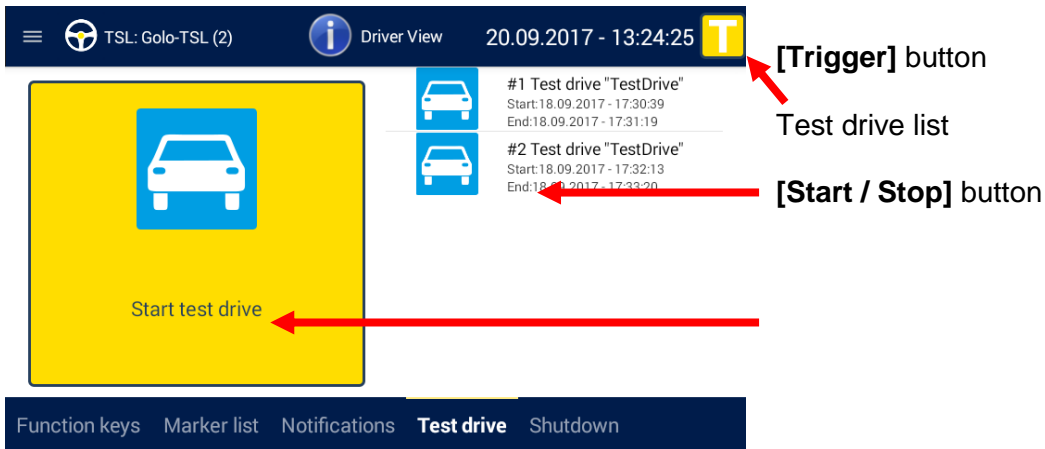

Figure 6.15: Tab sheet “Test drive”

After pressing [Start Test Drive] a new page appears where the settings for the test drive can be set.

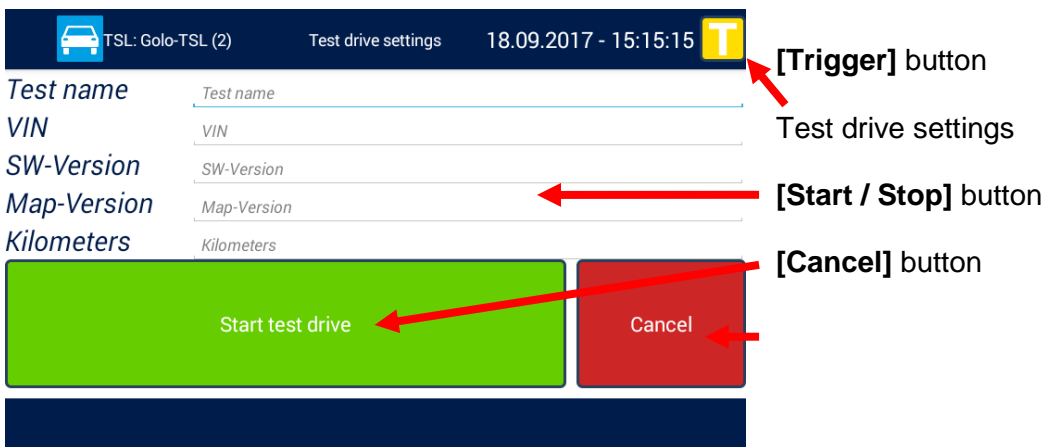

Figure 6.16: Tab sheet “Test drive settings”

If all needed details are entered, the site can be left by the green button [Start Test Drive] to reach an overview, where the test drive can be started with [OK], or cancelled with [Cancel].

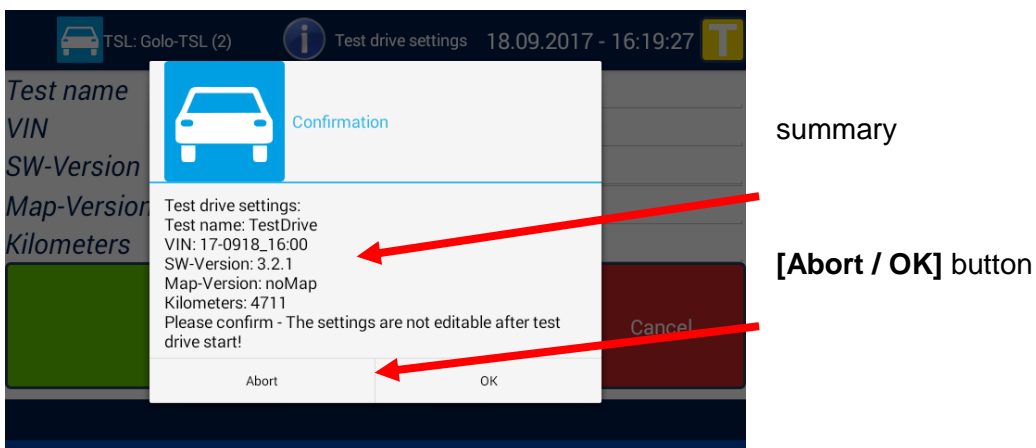

Figure 6.17: Test drive settings “Confirmation”

When the test drive is running, the recording can be stopped by the button **[Stop test drive]**. The test drive is even active, when the TSL cluster goes into standby in the meantime.

During a test drive, the title bar is orange and indicates permanently that a test drive is active.

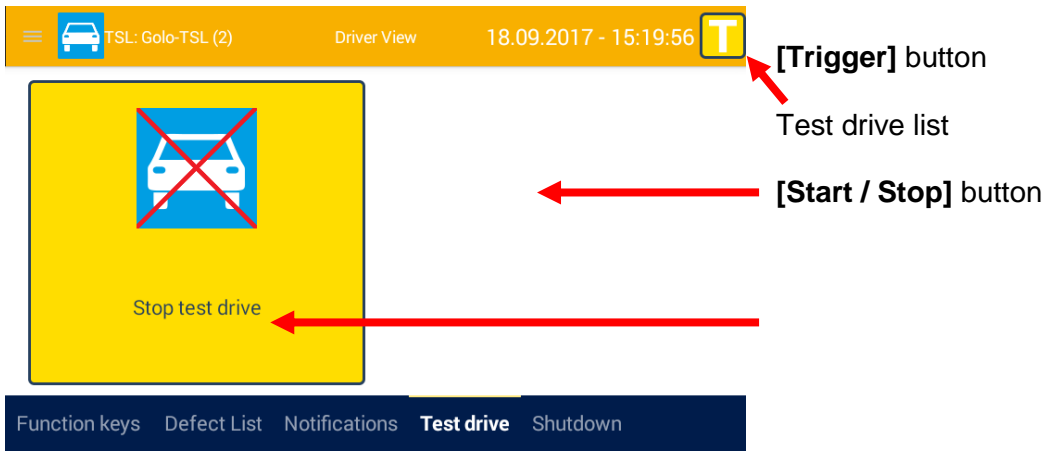

Figure 6.18: “Stop test drive”

6.2.2.5 Driver View – Shutdown

The whole TSL cluster can be shut down at once, with the button on the tab **[Shutdown]**

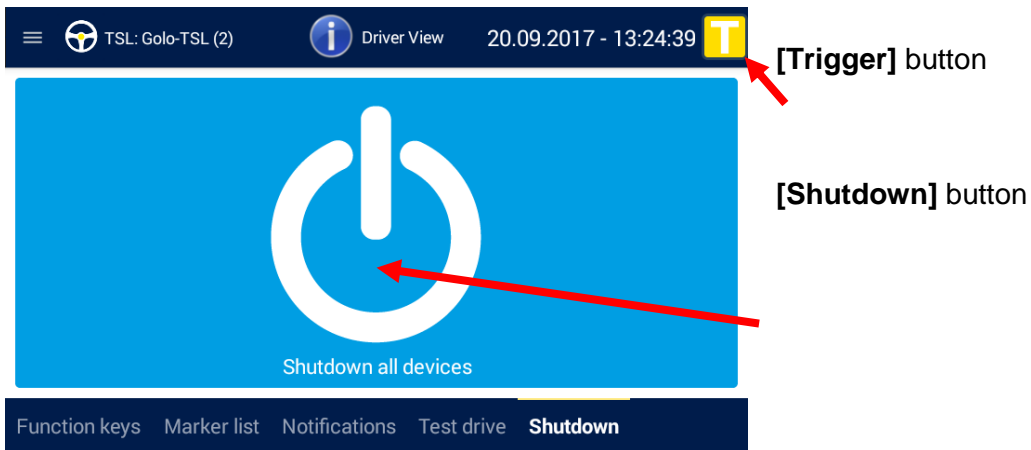

Figure 6.19: Tab sheet “Shutdown”

6.2.3 The application [Busload] |



Display of all available buses and their channels

The application **Busload** contains one combined tab sheet for each available interface of the connected loggers. The tab sheets are named after the respective bus interface.

If multiple loggers with active GPS / MOST25 / MOST150 are connected, each GPS resp. MOST interface is assigned a tab sheet.

6.2.3.1 Busload - CAN/Serial/LIN/Ethernet/Camera/CCP_XCP

Each of these tab sheets contains a tabular overview of all channels of the respective bus with the following displays (here using the example of the tab sheet **[CAN]**):

| Id | Name | Busload |
|----|---------|---------|
| #1 | HSCAN-1 | 0 % |
| #2 | HSCAN-2 | 0 % |
| #3 | HSCAN-3 | 0 % |
| #4 | HSCAN-4 | 0 % |

Navigation bar: CAN | Serial | FlexRay | LIN | Ethernet | Camera | MOST150

Labels: Channel number, Channel name, Bus load

Figure 6.20: Tab sheet “CAN”

6.2.3.2 Busload - MOST150

Each connected logger that receives MOST150 messages generates its own tab sheet [MOST150] with the following displays:

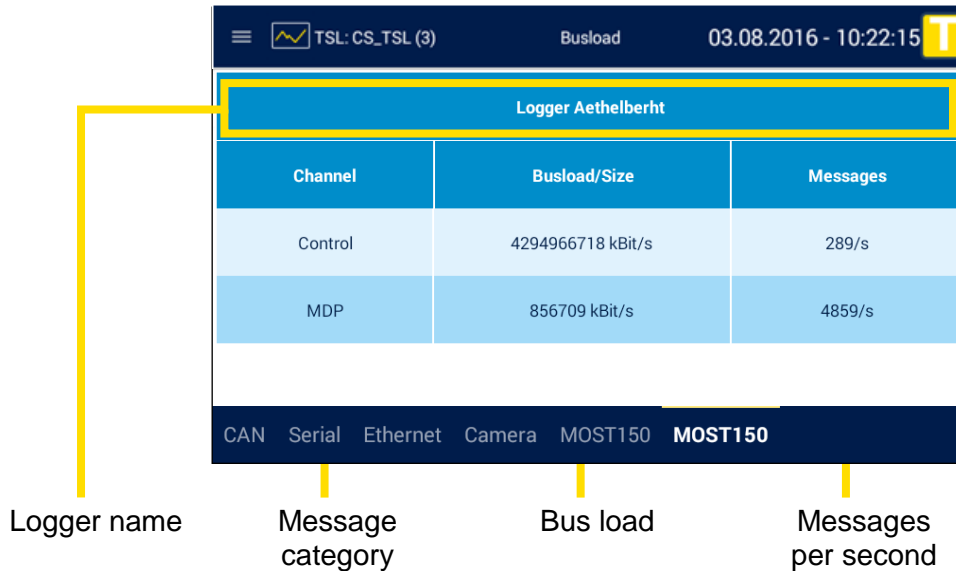

Figure 6.21: Tab sheet “MOST150”

If the window contains only the display of “Light off”, the cable is incorrectly connected or no MOST data is sent and the bus is inactive.

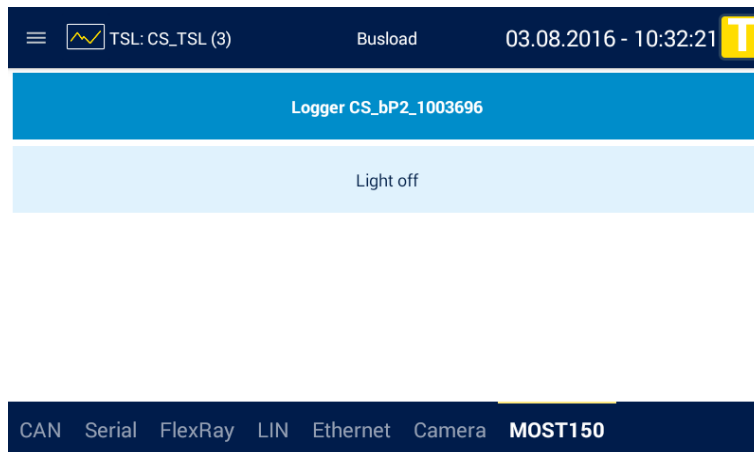

Figure 6.22: Tab sheet “MOST150”: Light off

In MOST150 the following categories of messages exist:

| Category | Meaning | | |
|--|--|-----------------------|-----------------|
| Control | Control data; for the passing of control messages; transmits up to 384 data byte | | |
| MDP | MOST Data Packet; transmits up to 1524 data byte | | |
| MEP | MOST Ethernet Packet; for the passing of Ethernet messages; transmits up to 1506 data byte | | |
| Streaming Channel/Channels | Synchronous data range; transmits up to 372 data byte | | |
| | Channel | Busload/Size | Messages |
| | *Number of streaming channels* Streaming Channels | *Bus load in bytes* B | (remains empty) |
| With only one streaming channel, the display under “Channel” is restricted to “Streaming Channel”. | | | |

Table 6.2: Message categories

6.2.3.3 Busload - GPS

Each connected logger that receives GPS data generates its own tab sheet **[GPS]** with the following displays:

| TSL: CS_TSL (3) Busload 03.08.2016 - 10:22:15 | |
|---|----------------|
| Latitude: | 48° 11' 14" N |
| Longitude: | 011° 35' 11" E |
| Altitude: | 605.8 M |
| Course: | 276.8° |
| Speed: | 0.0 km/h |

CAN Serial FlexRay LIN Ethernet Camera MOST150 **GPS**

Figure 6.23: Tab sheet “GPS”

| | |
|-------------|----------------|
| Longitude: | 011° 35' 11" E |
| Altitude: | 605.2 M |
| Course: | 276.8° |
| Speed: | 0.0 km/h |
| Satellites: | 03 |

CAN Serial FlexRay LIN Ethernet Camera MOST150 **GPS**

Figure 6.24: Tab sheet “GPS” – continuation

If the window contains only the display of “No GPS signal”, this may be for at least one of the following reasons:

- The GPS connection is disabled.
- The GPS receiver is not connected.

- No satellite or too few satellites were found (minimum 3).

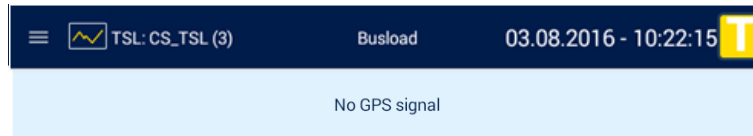
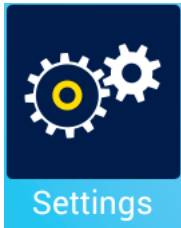

Figure 6.25: Tab sheet “GPS”: No GPS signal

6.2.4 The application [Settings] |



Adjustment of backlight and volume

The application **Settings** can be used for adjusting the brightness of the display as well as the volume of the audio playback. The interfaces of microphone and loudspeaker can be defined here too.

Via Settings, the display can be rotated by 180° too.

6.2.4.1 Settings - General

The window of the tab sheet **[General]** contains a total of five control elements:

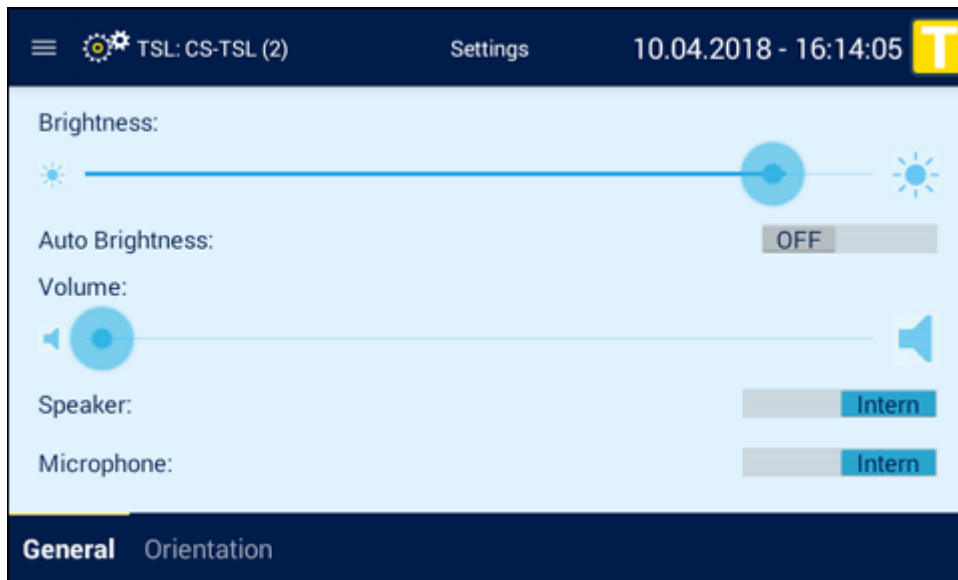
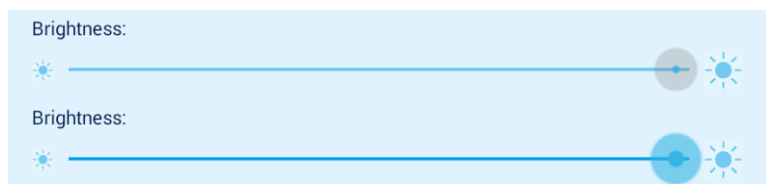
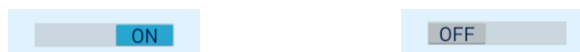

Figure 6.26: The view [Settings] => [General]

- Brightness scale with brightness slider



- ON/OFF button



3. Volume scale with volume slider

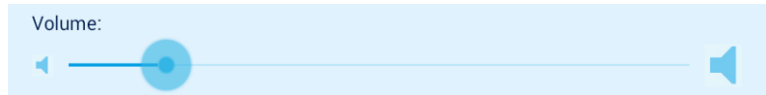

4. and 5. Intern/Extern button



To adjust a button, tap on the button or in the gray boundary.

To adjust a slider, swipe it to or tap on the desired position on the brightness scale.

More information on the operation is provided in chapter 7.

Refer to the following table for the meaning of the individual control elements.

| Operating element | Meaning |
|--|---|
| Brightness scale with brightness slider | Depending on the position of the slider on the scale, if the [OFF] button is visible, the backlight is: <ul style="list-style-type: none"> • dimmed (left) or • intensified (right). |
| [ON] button | Brightness is automatically adjusted. Brightness scale with brightness slider is inactive. |
| [OFF] button | Brightness is adjusted according to the position of the brightness slider on the brightness scale. Brightness scale with brightness slider is active. |
| Volume scale with volume slider | Depending on the position of the slider on the scale, the volume is: <ul style="list-style-type: none"> • decreased (left) or • increased (right). |
| [Intern] button | Remote Control Touch internal hardware is actuated. Acoustic signals are played back through the speaker and recorded through the microphone (see section 5.1.1). |
| [Extern] button | External hardware of the connected accessories is actuated. |

Table 6.3: Operating elements of the tab sheet “General”

Note:

The quality of playback and recording acoustic signals depends on the actuated hardware.

6.2.4.2 Settings – Orientation

Sometimes it makes sense during installation to mount the cables in a certain direction. In order to install the device more flexibly in this case, the display can be rotated by 180 °.

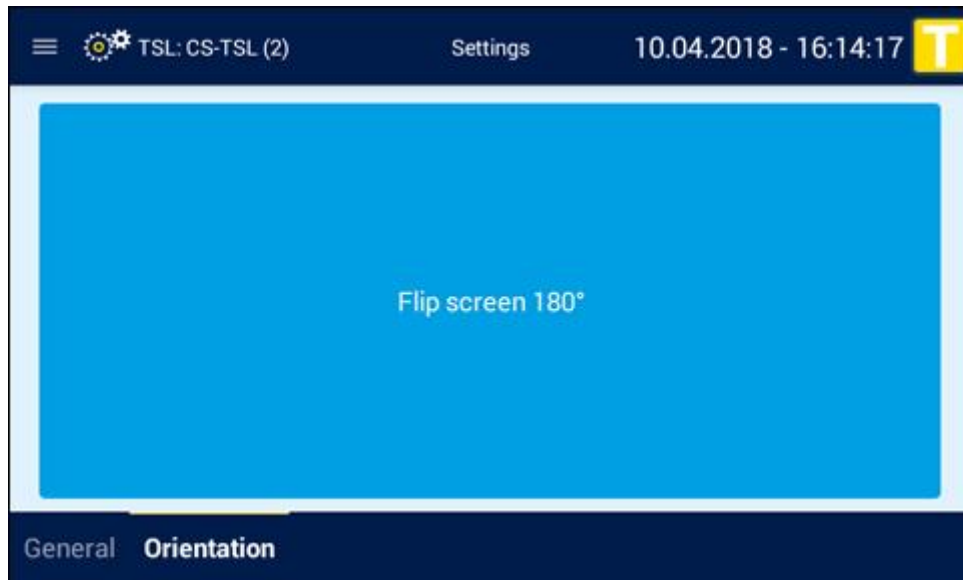

Figure 6.27: The view [Settings] => [Orientation]

The screen will rotate after pushing the big blue button [Flip screen 180].



Figure 6.28: Screen flipped at 180°

6.2.5 The application [TSA Monitor] |



Display of TSA modules

Since release 3.4.1 the RCTouch | BLUEPIRAT Remote offers the ability to show installed TSA Modules with the application **TSA Monitor**.

You'll find more information about TSA in the manual of the System Client.

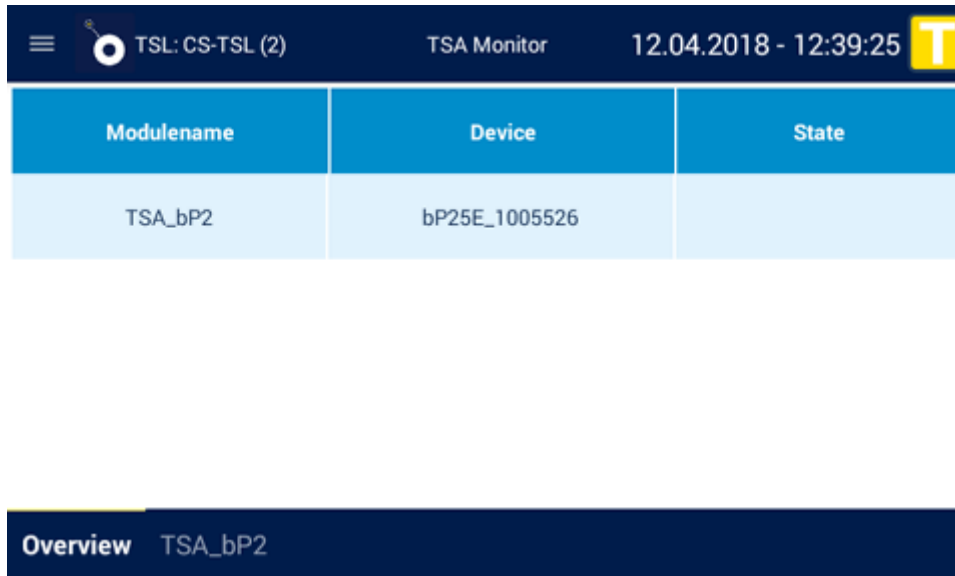

Figure 6.29: Overview of installed TSA modules

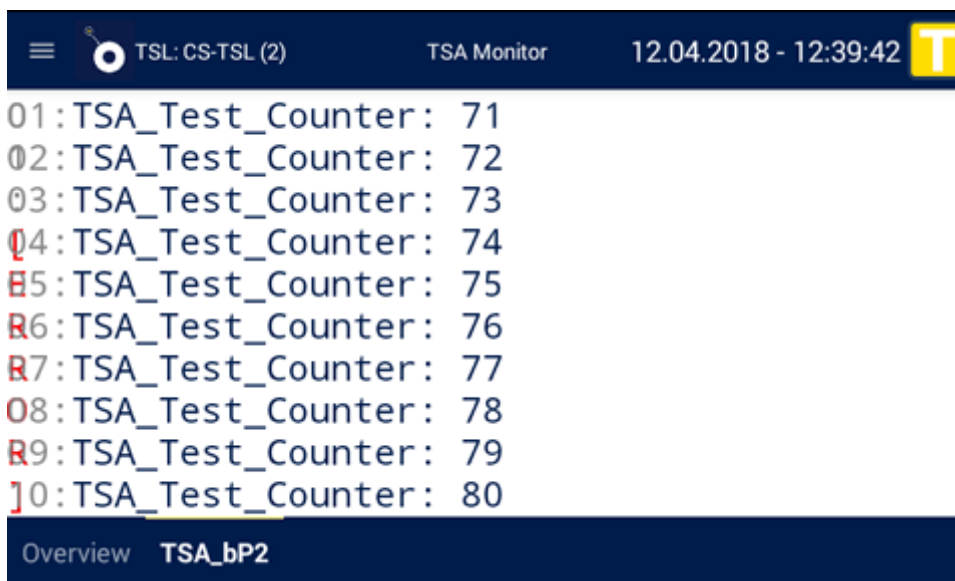
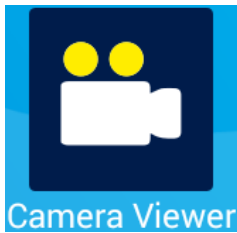

Figure 6.30: details of an installed TSA module

6.2.6 The application [Camera Viewer] |



Live view of an connected camera

The application **Camera Viewer** shows a liveview from all available cameras in the TSL cluster.

From firmware release 3.2.1, the live images of connected cameras can be shown on the display too.

This feature is implemented for:

- Mounting and adjusting the camera in a vehicle

Showing the video data permanently is in theory possible but not recommended cause this will generate too much traffic between the devices and can disturb the TLS network.

To see the pictures from the cameras open the **[Camera Viewer]** application from the **[Home]** screen and the configured cameras are displayed there in a list.

Note: This overview shows all configured cameras, independent if the camera is just connected or not.

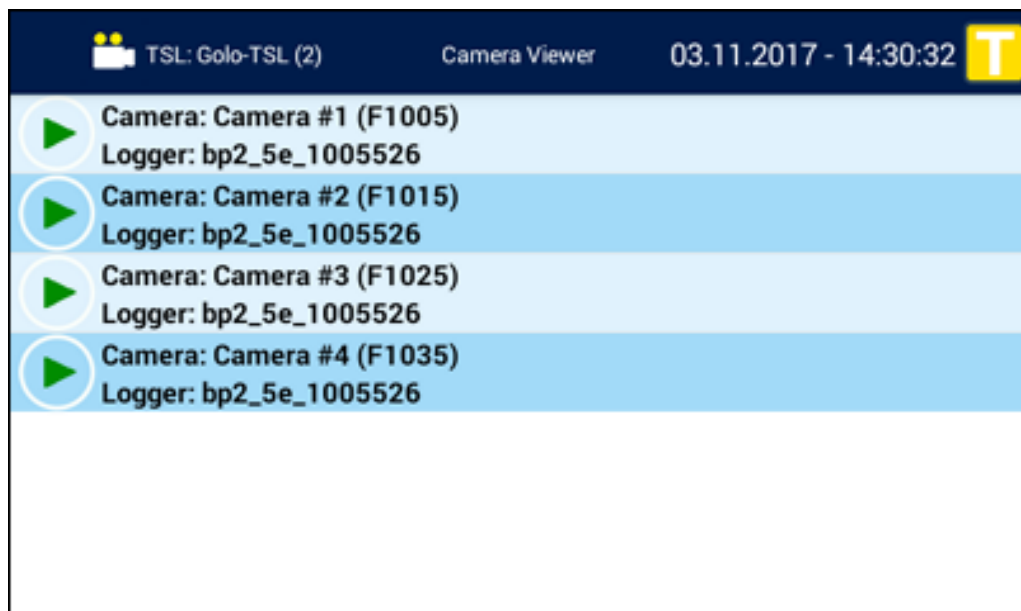

Figure 6.31: Camera Viewer: Camera overview

If you tip on one of the cameras in the list, the pictures of this camera are displayed. The example shows 4 pictures from different cameras which are connected to an Axis F44.

F1005-E | 113° | 1080p



F1015 | 53° - 108° | 1080p | Vario focus



F1025 | 92° | 1080p



F1035 | 194° | 1080p



Figure 6.32: Camera Viewer: Axis F44 and pictures of 4 different cameras

6.3 Display

The display of the **Remote Control Touch / BLUEPIRAT Remote** is similar to those of the data loggers. An overview to their meanings is provided in the following table. You can find the view that contains the display via the cross reference in the column "See".

| Display | Meaning | See |
|------------------------------------|--|--|
| Bus load | indicates the degree with which the bus is busy with data transfer | 6.2.2.3 6.2.3.2 |
| DHCP mode | can be configured under General → Network settings indicates whether the device functions as a server or a client or whether DHCP was disabled | Fehler! Verweisquelle konnte nicht gefunden werden. |
| Error count | indicates the number of active errors (can be viewed in the bug reporter) when the status is ERROR or WARNING | Fehler! Verweisquelle konnte nicht gefunden werden. |
| Device name | can be configured under General → Name provides orientation in the application and is part of the trace file's file name | 6.1.1 6.2.1 Fehler! Verweisquelle konnte nicht gefunden werden. |
| Device status | see Table 6.5: Device status messages | 6.2.1 Fehler! Verweisquelle konnte nicht gefunden werden. |
| Device type | see Status - Overview | 6.2.1.1 |
| Memory percentage protected | can be configured under General → Buffer indicates the percentage of the memory capacity that is protected | Fehler! Verweisquelle konnte nicht gefunden werden. |
| IP address | indicates the IP address of the device | 6.2.1 Fehler! Verweisquelle konnte nicht gefunden werden. |
| Channel name | can be configured under *Bus* → *Bus #...* → Name provides orientation in the application and is part of the trace file's file name | 6.2.2.3 |
| Channel number | serves as index for sorting the channel lists is obtained from the configuration in the System Client | 6.2.2.3 |
| Configuration name | can be configured under General → Name indicates the name of the configuration on the device | Fehler! Verweisquelle konnte nicht gefunden werden. |
| Logger name | can be configured under General → Name helps mapping logger-specific tabs | 6.2.3.2 |
| Markerlist | contains the markers of the set triggers sorted by index Each marker is specified by the time (date and time) the trigger was set. The  button is used to play the voice note. | 6.2.2.2 |
| Message category | see Table 6.2: Message categories | 6.2.3.2 |
| Storage capacity | depends on the internal memory Since the Remote Control Touch does not have internal memory, the tab shows "0 GB". | Fehler! Verweisquelle konnte nicht gefunden werden. |
| Subnet mask | indicates the subnet mask of the connected device | Fehler! Verweisquelle konnte nicht gefunden werden. |

| | | |
|---------------------------------|--|--|
| Memory percentage filled | indicates the percentage of the memory capacity that is filled | Fehler! Verweisquelle konnte nicht gefunden werden. |
|---------------------------------|--|--|

Table 6.4: Displays overview

6.3.1 Device status

The device status may display the following messages:

| Message | Form | Meaning | Data recording |
|-----------------|--------------------|----------------------------|----------------|
| ERROR | red flashing | device in error mode | jeopardized |
| FWUPDATE | dark blue flashing | logger firmware is updated | stopped |
| MEMORY | dark blue flashing | lack of memory capacity | jeopardized |
| OK | dark blue | normal operation | normal |
| RING | dark blue flashing | logger in ring buffer mode | normal |
| WARNING | dark blue flashing | jeopardized operation | normal |

Table 6.5: Device status messages

More information on the device status is provided in the user guides of the data loggers, section Memory space and level.

6.3.1.1 Memory full

If the memory of a connected logger is full, this will be displayed as a flashing [MEMORY] in the Status / Overview

If the memory of a connected logger is full, this will display a flashing [MEMORY] appears in the Status / Overview display.

| Trigger Count: | | | | 26 |
|----------------|--------------|--------|---------|--------------|
| Logger | IP | Status | Type | FW |
| bPMini_LIN_193 | 192.168.0.89 | OK | bP Mini | 02.04.00.190 |
| bPMini_FR_201 | 192.168.0.88 | MEMORY | bP Mini | 02.04.00.190 |
| bPMini MOST150 | 192.168.0.91 | OK | bP Mini | 02.04.00.190 |

Overview RCT bP2 bPMini_LIN_193 bPMini_FR_201 bPMini_MOST150

Figure 6.33: Memory full note in the Status / overview display

When you tap the bottom tab bar on the logger with the "Memory" status, the detailed view of the logger opens. In this view the two flashing cells [100% filled] and [Memory], serve as an indication for the full memory.

| TSL: TSL_2_4 (5) | | Status | 07.07.2016 - 09:15:46 T | |
|------------------|---|-------------|--|--|
| Logger: | bPMini_FR_201 | Config: | default | |
| Network: | IP 192.168.0.88 Subnet 255.255.255.0 | DHCP Client | Terminal-IP 10.1.191.179 Subnet 255.255.0.0 | |
| Memory: | 50 GB | 100% filled | 100% protected | |
| Status: | MEMORY | | | |

Overview RCT bP2 bPMini_LIN_193 **bPMini_FR_201** bPMini_MOST150

Figure 6.34: Memory full-status in the detail view

6.4 Other views

Other views include:

- views that appear due to the configuration of a connected logger,
- views that can only be closed via the Remote Control Touch and/or
- views that appear outside the application.

6.4.1 AlertDialog

| | |
|---------------------|------------------------------------|
| Precondition | none |
| Timing | Internal communication has failed. |
| Options | close popup |

To close the popup, tap on **[OK]**. Then repeat the last command.

6.4.2 FW-Update

| | |
|---------------------|--|
| Precondition | none |
| Timing | Remote Control Touch / BLUEPIRAT Remote firmware is updated. |
| Options | none |

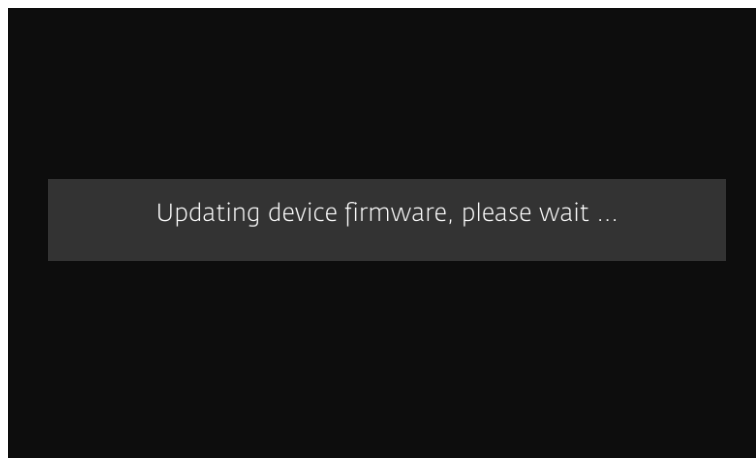

Figure 6.35: FW-Update view

6.4.3 Launcher

| | |
|---------------------|--|
| Precondition | none |
| Timing | Remote Control Touch / BLUEPIRAT Remote is switched on. (before the application) |
| Options | close popup |

Within the view “Launcher” a safety message in a popup appears after a short time (see section **Fehler! Verweisquelle konnte nicht gefunden werden.**).

To close the popup and use the application, tap on **[Accept]**.

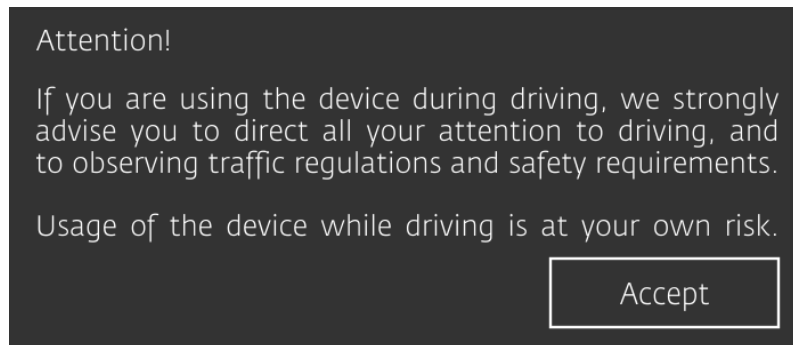

Figure 6.36: Popup in Launcher view

6.4.4 RC Monitor

| | |
|---------------------|---|
| Precondition | Remote Control Monitor is configured An application is open. |
| Timing | Complex trigger configured to the <Action> [Display Remote Control Monitor] is actuated. (see section Fehler! Verweisquelle konnte nicht gefunden werden.) |
| Options | set trigger, close view |

The view is constantly updated and depends on its configuration in the System Client, whose manual also describes the feature in detail.

To close the view, press the Home button or tap on **[Close]**.

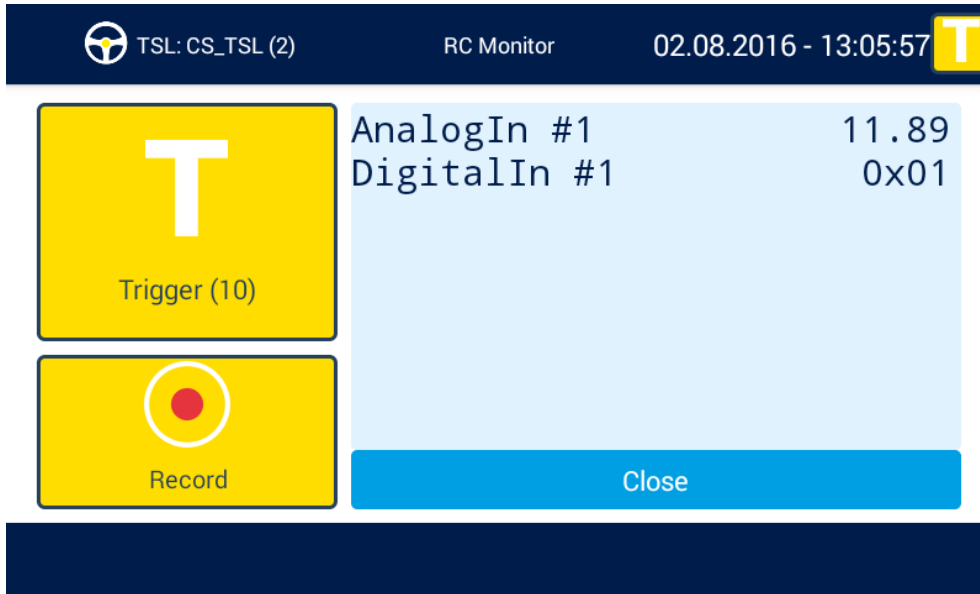

Figure 6.37: Window “RC Monitor”

6.4.5 RC Text

| | |
|---------------------|---|
| Precondition | An application is open. |
| Timing | Complex trigger configured to the <Action> [Display notification on Remote Control] is actuated. (see section Fehler! Verweisquelle konnte nicht gefunden werden.) |
| Options | set trigger, close view |

The view is not updated and depends on the configuration in the System Client.

To close the view, press the Home button or tap on **[Close]**.

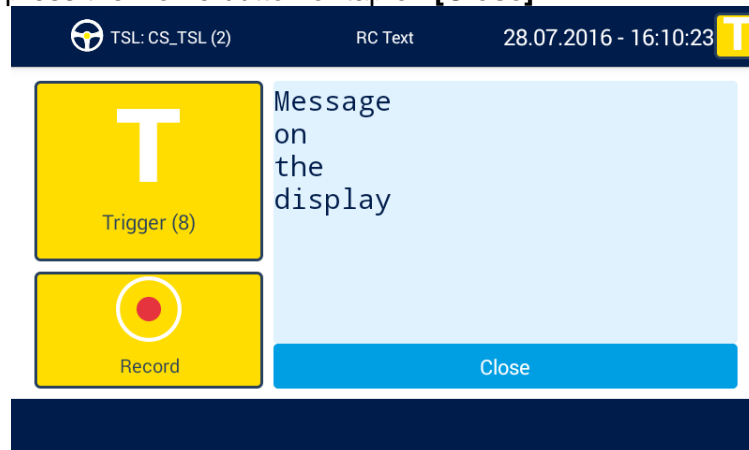

Figure 6.38: Window “RC Text”

6.4.6 Standby

| | |
|---------------------|---|
| Precondition | none |
| Timing | Remote Control Touch / BLUEPIRAT Remote is switched off or not used for an extended period. (after the application) |
| Options | none |

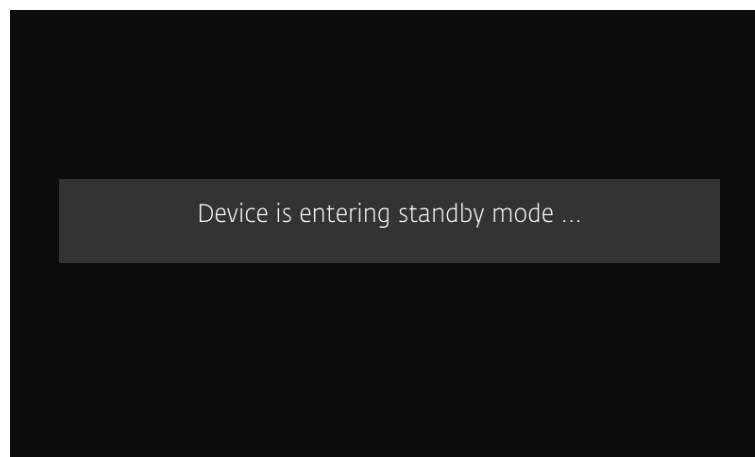

Figure 6.39: Standby view







To exit the standby mode, press the Home button or tap on the screen.

6.5 Restrictions of the RC Touch in stand-alone mode

The **BLUEPIRAT Remote** can be configured by the System Client like every other data logger of Telemotive. For **Remote Control Touch** the following restrictions are valid:

6.5.1 Remote Control Touch applications

In standalone mode the **Remote Control Touch** is not connected to any data logger. Some functions are therefore not available.

- The application  Status remains unaffected.
- The application  Busload is inactive.
- The application  Driver View is inactive.
- The application  Settings remains unaffected.
- The application TSA Monitor  is inactive.
- The application **Camera Viewer**  is inactive.

6.5.2 System Client applications

The System Client also provides less functionality for **Remote Control Touch** than for a data logger.

For a data logger all seven applications are available:

1. Live View
2. Online Monitor
3. Download data
4. Convert data
5. Open configuration
6. Update firmware
7. Open bug report

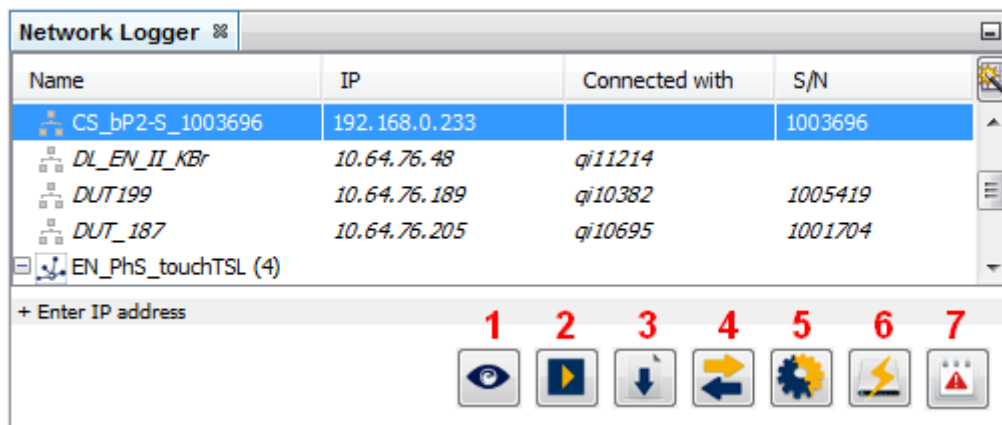

Figure 6.40: Available applications for a data logger

Find more information about the System Client applications in the **User manual for the System Client**.

In standalone mode only the following applications are available:

1. Live View
5. Open configuration
6. Update firmware
7. Open bug report

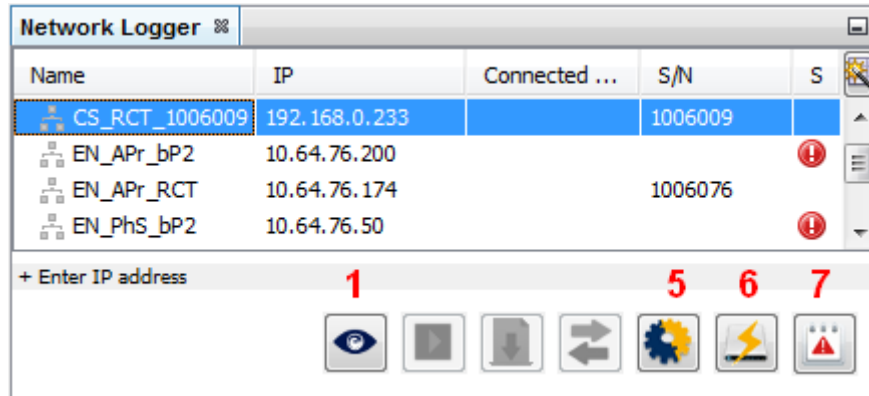

Figure 6.41: Tab “Network Logger” in standalone mode

The applications **[Update firmware] (6)** and **[Open bug report] (7)** provide the same functional range in both modes. Find the applications descriptions in the **User manual for the System Client**.

The application **[Open configuration] (5)** provides less categories in the configuration tree (e.g., **[General]**) and less sub-items (e.g., **[Name]**) than for a device integrated in the TSL network.

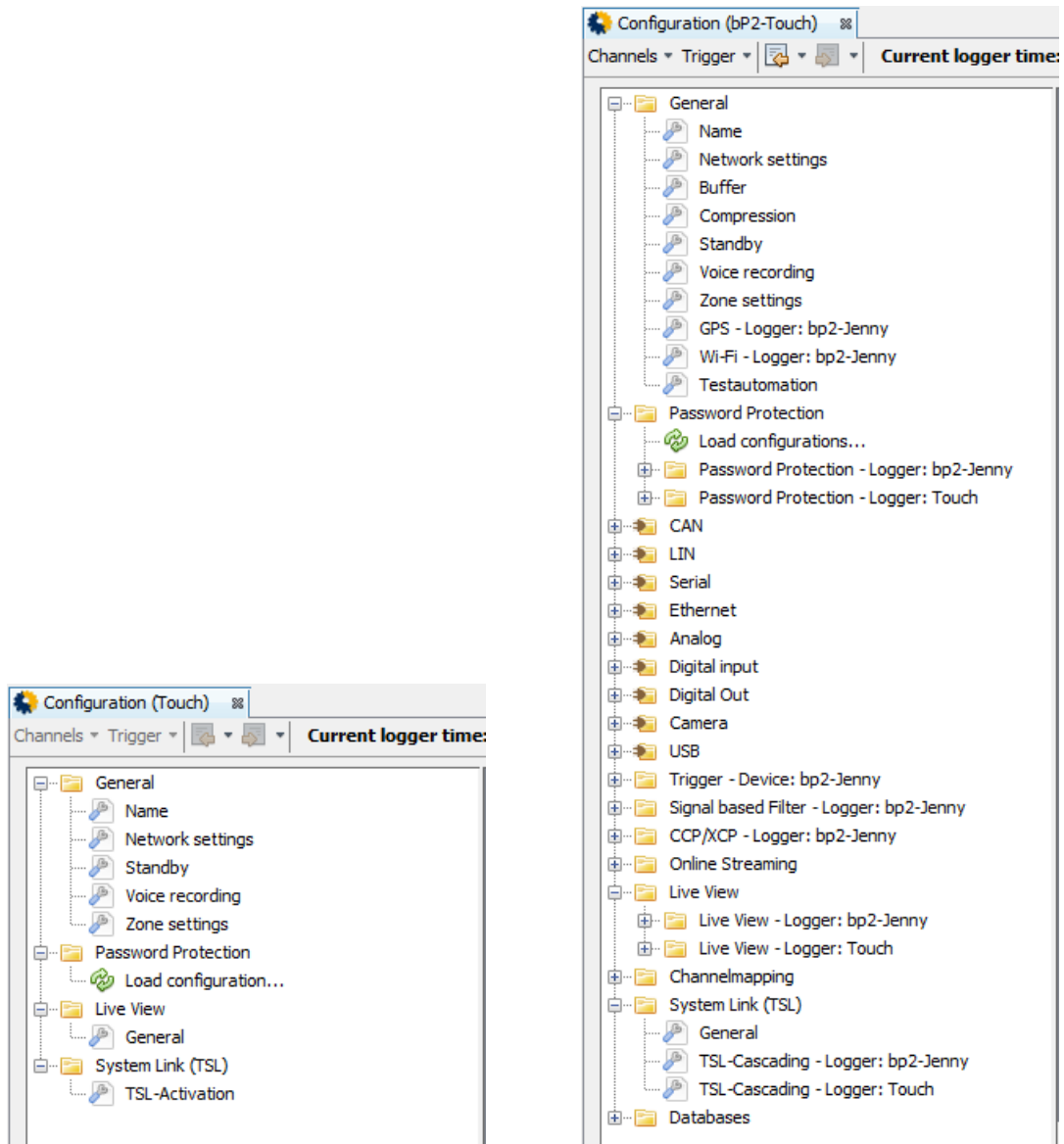

Figure 6.42: Configuration trees: Standalone mode (left) – TSL (right)

Find more information about components of the configuration tree in the **User manual for the System Client**.

7 Operation

Important:

Only use the tip of the finger to operate the Remote Control Touch / BLUEPIRAT Remote.

This chapter describes instructions that are possible using the devices.

7.1 Switching the device on

Press the Home button.

- Active LED and State LED light up briefly. Active LED then flashes green.
- View “Launcher” with advancing progress bar appears on the screen.
- Popup with warning appears.

Tap on **[Accept]**.

- Popup with warning disappears.

The Remote Control Touch is switched on when:

- the tab sheet **[Overview]** appears and
- the Active LED lights green.

7.2 Switching the device off

Press and hold the Home button until the Active LED pulses green.

- Active LED pulses green.
- View “Standby” appears on the screen.

The Remote Control Touch is switched off when:

- the view “Standby” disappears and
- the Active LED goes out.

7.3 Scrolling through applications

If the application contains more than one tab sheet, you have the option to scroll.

Note:

In the application Driver View , there is a risk of setting unwanted triggers when scrolling through. You should therefore use the tab bar to change the tab sheet.

Swipe the tab sheet horizontally:

- to the left The tab sheet adjacent to the right appears.
- to the right The tab sheet adjacent to the left appears.

If there is no tab sheet adjacent to the left or right, this is indicated by a gray margin on the left respectively right edge of the screen.

7.4 Changing application

To reach another application, you have two options:

8. Press the Home button ...
 - Active LED lights up briefly.
 - <Home> view appears.
9. Open the side menu (see section 7.9) ...

and tap on the icon of the desired application.

7.5 Actuating functionkey

Navigate to the tab sheet **[Functionkeys]** in the application Driver View .

Tap on the desired functionkey that was previously assigned with a “complex trigger”, see section **Fehler! Verweisquelle konnte nicht gefunden werden.**

- The device responds according to the <Action> that was set in the configuration for the <Event> **[Key Stroke]** using a functionkey as <Key>.

7.6 Adjusting backlight

Navigate to the tab sheet **[General]** in the application Settings .

7.6.1 Automatic adjustment

If you want the brightness of the screen to adjust automatically, tap on the gray **[OFF]** button under <Auto Brightness>.

- Brightness is automatically adjusted.
- The blue **[ON]** button is active.
- Brightness scale with brightness slider is inactive.

7.6.2 Manual adjustment

If you want to adjust the brightness of the screen manually, tap on the blue **[ON]** button under <Auto Brightness>.

- The gray **[OFF]** button is active.
- Brightness scale with brightness slider is active.

Swipe the brightness slider to the desired position or tap on the desired position on the brightness scale.

- Brightness is set according to adjustment.
- A brief fade-in indicates the new brightness value set in percent.

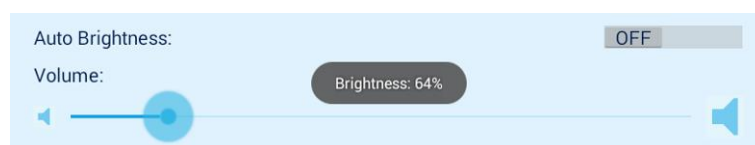

Figure 7.1: Fade-in after adjusting the brightness

7.7 Adjusting volume

Note:

A tone is produced to simulate the newly set volume. If you set the volume to “Volume: 0%”, the Remote Control Touch is mute. Its acoustic signals are switched off.

Navigate to the tab sheet **[General]** in the application Settings .

Swipe the volume slider to the desired position or tap on the desired position on the volume scale.

- A change in volume is indicated by a tone and at the same time it simulates the newly set volume.
- A brief fade-in indicates the new volume value set in percent.

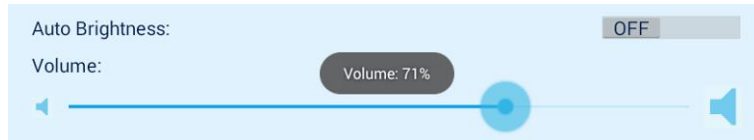

Figure 7.2: Fade-in after adjusting the volume

7.8 Changing tab sheet

To reach other tab sheets within an application, tap in the tab bar on the tab of the desired tab sheet.

- Selected tab sheet appears.

To reach tab sheets in other applications, switch to the application of the desired tab sheet first (see section 7.4) and continue to proceed as just described.

7.9 Opening and closing side menu

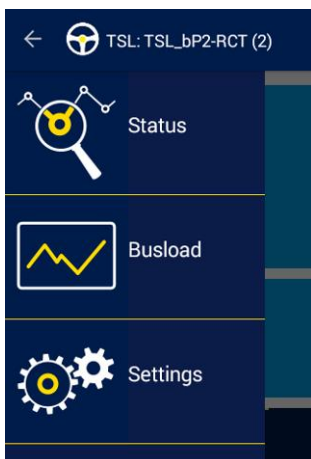

To open the side menu, you have two options:

10. Tap on the  button.
11. Swipe from the left edge of the screen to the right.

To close the side menu, you have three options:

12. Tap in the window of the tab sheet.
13. Tap on the  button.
14. Swipe from the right to the left edge of the screen.

Figure 7.3: Example side menu

7.10 Setting marker / /

There is a global trigger button for setting marker in all views of the Remote Control Touch in the top right corner. In the following example, you can see the Busload view.

| Id | Name | Busload |
|----|------------|---------|
| #1 | BODY-CAN-1 | OFF |
| #2 | FA-CAN | OFF |
| #3 | A-CAN | OFF |
| #4 | SF-CAN | OFF |

Figure 7.4: Busload view with global trigger button

You can set a marker by tapping the yellow trigger button. After you have set a marker, you can see a small grey popup including the marker number, the date and the time of the marker.

| Id | Name | Busload |
|----|------------|---------|
| #1 | BODY-CAN-1 | OFF |
| #2 | FA-CAN | OFF |
| #3 | A-CAN | OFF |
| #4 | SF-CAN | OFF |

Figure 7.5: Marker popup in the Busload view

7.10.1 Marker with voice note



Navigate to one of the tab sheets **[Function keys]** / **[Marker list]** / **[Notifications]** in the application Driver View .

Note:

The quality of the recording and playback is dependent on the settings of <Speaker> and <Microphone> on the tab sheet **[General]** (see section 6.2.4).

Tap on **[Record]** to set a marker with voice note on the connected devices.

- Sound recording starts. Recording length is indicated on the button with “Recording... elapsed time: *hour*:*minute*:*second*”.

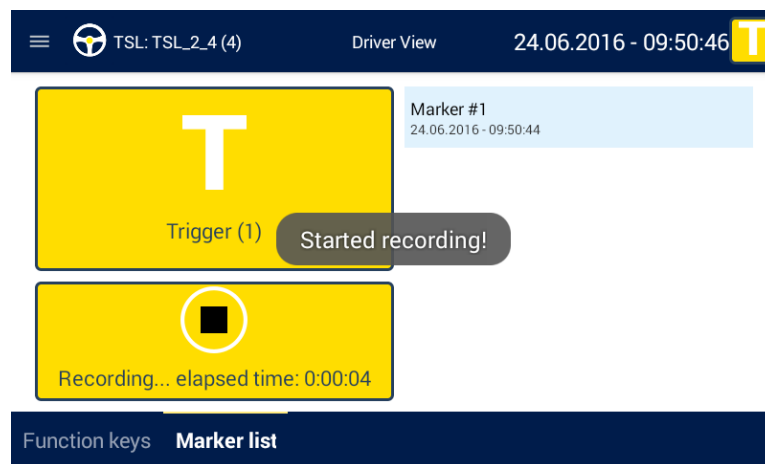

Figure 7.6: Voice note recording starts

- A fade-in tells you under which index and timing (date and time) the marker was set.
- Marker appears on the tab sheet **[Markerlist]**.
- The red status LED flashes during recording

After you have started a record, you can see a small grey popup including the marker number, the date and the time of the marker. The marker appears in the tab **[Marker list]**. While you are recording a message, the red state-LED is pulsating.

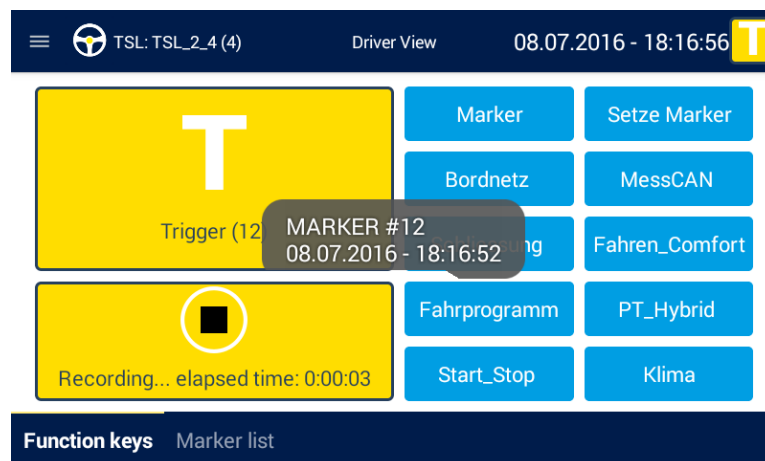



Figure 7.7: Voice note recording starts

To stop the recording, tap on **[Record]** again or wait until the <Max. recording length> configured in the System Client elapses.

- Two brief fade-ins appear one after the other:
 - “Stopped recording!” Sound recording is stopped.
 - “Uploaded record!” Sound recording is uploaded.
-  button appears in the Marker entry.

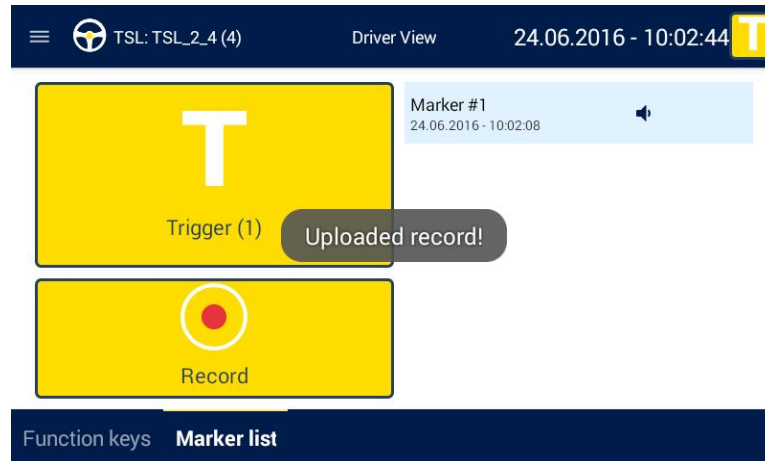

Figure 7.8: Voice note recording stops

7.10.2 Marker without voice note



Note: Setting a marker without voice note is confirmed acoustically. If you do not hear an acoustic signal, increase the volume (see section 7.7).

Tap on **[Trigger]** to set a trigger on the connected devices.

- A tone sequence indicates that a marker was set.
- A brief fade-in tells you under which index and timing (date and time) the marker was set.
- Marker appears on the tab sheet **[Markerlist]**.

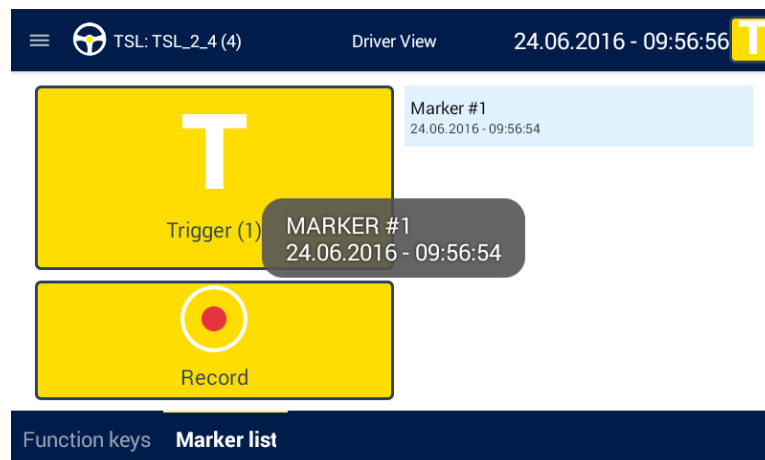

Figure 7.9: Marker set

7.11 Playing voice note

Note:

If you do not hear an acoustic signal, increase the volume (see section 7.7).

The quality of the recording and playback is dependent on the <Speaker> and <Microphone> settings on the tab sheet [General] (see section 6.2.4).

Navigate to the tab sheet [Markerlist] in the application Driver View .

Tap on the  button in the marker entry.

- Voice note of the marker is played.
- The following duration display complements the marker entry.

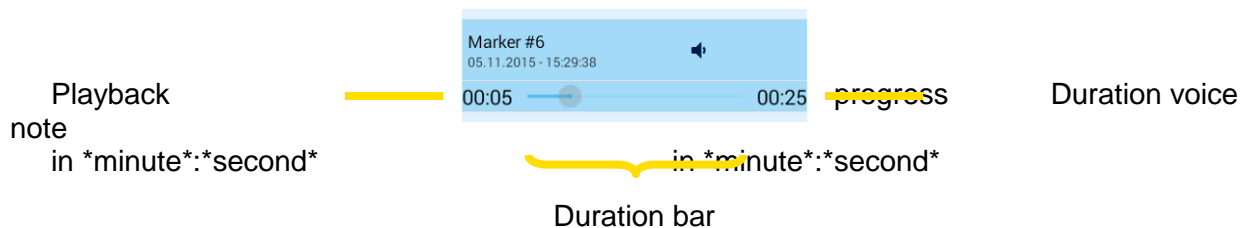



Figure 7.10: Voice note duration display

If you tap on a second  button while the voice note is played, the playback is stopped and the second voice note is played.

If you want to stop playing the voice note prematurely, tap on the  button again.

The duration display disappears when the playback of the voice note has ended.

7.12 Scrolling through tab sheet

If the window exceeds the height of the tab sheet, you have the option to scroll.

Swipe the tab sheet vertically:

- upwards Window is scrolled down.
- downwards Window is scrolled up.

If the window reached the very top or bottom, this is indicated by a gray margin on the top respectively bottom of the screen.

7.13 Scrolling through tab bar

If the tabs exceed the width of the tab bar, you have the option to scroll.

Swipe the tab buttons horizontally:

- to the left Tabs adjacent to the right appear.
- to the right Tabs adjacent to the left appear.

If there is no tab adjacent to the left or right, the tab bar turns gray on the left respectively right edge of the screen.

7.14 Updating firmware

Find more information on firmware update in the **User manual for the System Client**.

Note:

Only update the Remote Control Touch / BLUEPIRAT Remote firmware with the vehicle at standstill.

In the TSL network, the data logger does not record any data during the update.

Launch the System Client by double-clicking the shortcut “System Client” on the desktop or in the start menu.

Select the desired device in the window <Network Logger>.

- Selected line is highlighted blue.

Click on the application **[Update firmware]** .

- The tab <Firmware- / Licenses update> opens.



Figure 7.11: Tab “Firmware- / Licenses update”

Note:

If you operate the device in the TSL network, apply the following steps on all TSL members.

Under <New firmware> click on **[Open]**.

- Dialog opens.

Select the desired firmware, click on **[Open]**.

Note:

For the Remote Control Touch as well as BLUEPIRAT Remote you need the same firmware as for the BLUEPIRAT Mini.

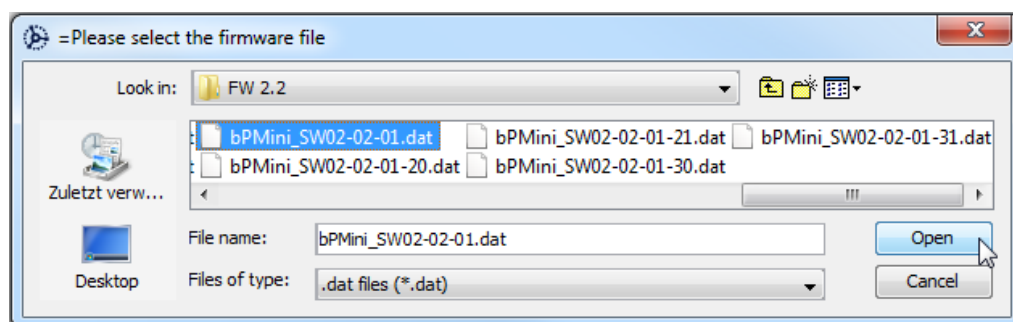

Figure 7.12: Opening firmware-packet

- Selected firmware appears in the display field.



Figure 7.13: Valid firmware-packet

Note:

If you select an invalid firmware-packet, the following notice message appears and the [Update firmware...] button remains inactive.

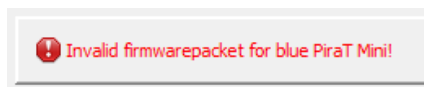

Figure 7.14: Notice message for invalid firmware-packet

Click on [Update firmware...].

- Firmware file is verified.
- Dialog opens.

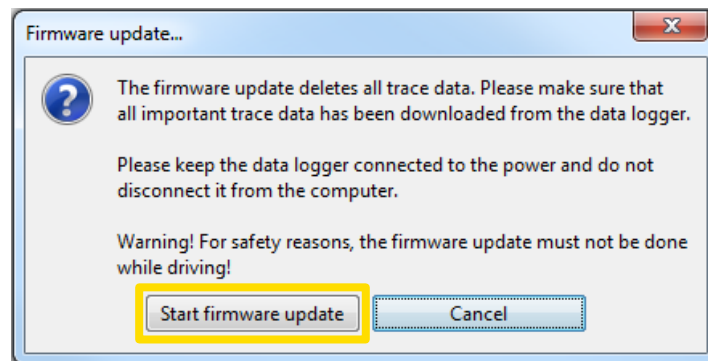

Figure 7.15: Notice message before firmware update

Follow the dialog instructions.

Click on [Start firmware update].

- View "FW-Update" appears.
- State LED lights red.
- Dialog opens.

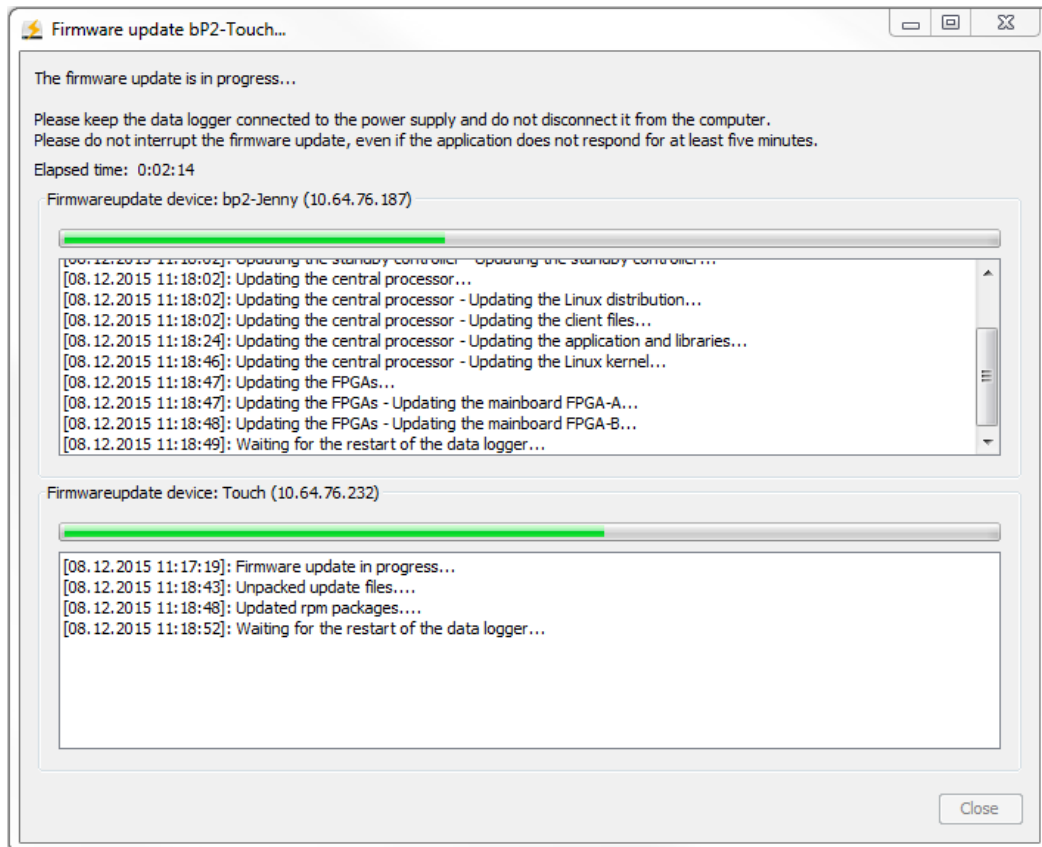

Figure 7.16: Advancing firmware update

The firmware is updated when:

- the view “FW-Update” disappears,
- the State LED goes out and
- the **[Close]** button is active.

8 Maintenance provisions, safety regulations and Regulatory Information

Note according to standard EN55011:2009

The device is used in an industrial environment. Due to occurring, grid-bound as well as radiated disturbances, it might possibly be difficult to ensure compliance with electromagnetic compatibility in other environments. The cable length shall not exceed 3 meters.

Cleaning

The device may only be cleaned with a clean cloth slightly dampened with water. Other cleaning agents such as gasoline, alcohol, etc., may not be used.

Maintenance

The device is maintenance-free. The case must not be opened by the customer. Unauthorized modifications will void the warranty.

Fuse

In case of failure, the customer may change the fuse of the cable set or fuses accessible from outside only. The fuse may only be replaced with a fuse of the same type and nominal current rating.

Disposal

Disposal of the unit, must be in accordance with the statutory laws and regulations.

Instruction on installation

Assembly of the device shall only take place in all three specified axes.

Operational temperature

Operation of the device shall only be performed within the temperature range specified in the data sheet (see chapter 9 and 10).

All tests to determine the valid operational temperature are performed under laboratory conditions. In real operation deviating temperatures can occur. Internal cut-off mechanisms exist, that prevent impermissible heating of the device's components.

A sufficient ventilation is to be taken into consideration. The unit and other components shall not be stacked atop each other provided that there is no adequate cooling ensured and the device shall be used in ambient temperatures exceeding +25°C.

During operation under unfavorable circumstances case temperatures that exceed +70°C can occur, as the metal case contributes directly for the passive cooling of the unit. At elevated ambient temperatures the case shall not be touched due to risk of injury. Operation of the device is only permissible in industrial premises with restricted access.

Storage conditions

The device may only be stored within a temperature range of - 20 °C to + 85 °C.

Condensation

During condensation the unit must not be activated. For this purpose appropriate waiting periods must be taken into consideration.

Environmental conditions

The unit must not be used in outdoor areas or unfavorable environmental conditions such as moisture, high air humidity or dust. Furthermore it is forbidden to operate the device in flammable or explosive atmospheres. The maximum power supply voltage must not exceed +30V. Overvoltage can destroy the device and voids the warranty.

Cable sets

When inserting the cable sets in the usual case, only a slight force is required. At an increased mechanical resistance during insertion of the cable set, the correct alignment of the pins should be checked.

Special cable sets are to be manufactured strictly according to the sheet of the instruction manual containing the pin assignment, whereby an extra fuse provided on the cable set must be considered. The connectors specified in the instruction manual should be used.

The cable sets' temperature range is restricted to -20°C to +70°C due to the banana plugs.

Only valid for the power supply connection of the BLUEPIRAT Remote:

Two pairs of pins of the 26-pin sub-d connector serve as a terminal part of an electrical interconnection between the unit and the power source. Each pair of related pins is assigned to only one type of electrical potential, that means an interconnection to positive electrical potential (Klemme 30/Clamp 30) for one related pair and the negative one (Klemme 31/Clamp 31) for the other matching pair.

However a conductive connection of one related pair of pins with two different electrical polarities results in short circuiting and destruction of the device in case of a missing suitable fuse.

Mounting

In laboratory setups and automobiles the units must be attached in such a way, that it is ensured against dropping, slipping and skidding.

Positioning of the antenna

While operating the device in an automobile, the connected antennas must not be located outside of the vehicle.

Replacing the battery

A lithium button cell is located within the device, which must be only replaced by MAGNA Telemotive GmbH.

Mechanical exposure

+++++ Environment during operation +++++
 Height: -300 to 5500 m

+++++ Environment out of service +++++
 Height -300 to 12000 m

Proper operation

The remote control touch must exclusively be utilized with the application of MAGNA Telemotive GmbH.

- The application is solely compatible with System Client
- Wiring with third-party units is conducted at your own risk
- In use while driving is at your own risk
- If you are using the device while driving, we strongly recommend to focus your attention on the road traffic and the safety regulations according to local road traffic regulations. (see Figure 6.36: Popup in Launcher view)

Any use other than described results in damage to the product. It also involves risks such as short circuit, fire, electric shock, etc. The entire product may not be modified or adapted.

8.1 Regulatory Information only for the Remote Control Touch

MAGNA Telemotive GmbH

Remote Control Touch

This device complies with Part 15 of the FCC Rules. Operation is subject to the following two conditions: (1) this device may not cause harmful interference, and (2) this device must accept any interference received, including interference that may cause undesired operation.

Note:

This equipment has been tested and found to comply with the limits for a Class A digital device, pursuant to part 15 of the FCC Rules. These limits are designed to provide reasonable protection against harmful interference when the equipment is operated in a commercial environment. This equipment generates, uses, and can radiate radio frequency energy and, if not installed and used in accordance with the instruction manual, may cause harmful interference to radio communications. Operation of this equipment in a residential area is likely to cause harmful interference in which case the user will be required to correct the interference at his own expense.

In relation to § 15.21 Information to user:

Caution:

Changes or modifications to the device, which are not expressly permitted in the operating instructions, could void the user's authority to operate the equipment.

In relation to § 15.27 Special accessories:

To comply with the necessary regulations, the device must be used with S/FTP (Screened Foiled Twisted Pair) ethernet cables with category 7 or at least 6A and with the power cableset provided by the MAGNA Telemotive GmbH.

9 Data sheet Remote Control Touch

| | |
|---|--|
| General data | |
| Supply voltage | 13.8 V |
| Power unit voltage | 7 V to 28 V for system startup 5 V to 29 V operating voltage Deviation +/-8% |
| Supply voltage reverse-connect protection | yes |
| Short circuit proof | yes |
| Operating current (typ.) | 350 mA (@ 13.8 V) |
| Operating current (max.) | < 2000 mA (@ 13.8 V) |
| Power consumption in standby | < 1 mA |
| Operating temperature | - 20 °C to + 60 °C |
| Storage temperature | - 20 °C to + 85 °C |
| Weight (approx.) | 415 g |
| Power management | |
| Startup time from standby to full operation | 35 s |
| Wake-up capability | KL 15, trigger button |
| Case | |
| Dimensions (approx.) | 5.91" x 3.62" x 0.98" (150 x 92 x 25 mm) |
| Operating elements | Home button |
| State/Active LEDs | STATE, ACTIVE |
| Connections | |
| Side view, from the right | 8-pol LEMO socket: Power supply, 1x LS-CAN 2x Gbit Ethernet (RJ45) |
| Rear side | 4-pol audio jack plug stereo out/microphone (3.5 mm) OMTP Micro USB 2.0 |
| Screen | |
| Size | 5" |
| Resolution | 800 x 480 |
| Colors | 16.7 million |
| Luminance | 700 cd/m ² |
| Touch function | Resistive, multi-touch |

Table 9.1: Data sheet Remote Control Touch

[Index](#)

10 Data sheet BLUEPIRAT Remote

| | |
|---|---|
| General data | |
| Nominal power supply voltage | 13.8 V |
| Power supply voltage | 7 V to 28 V for system startup 5 V to 29 V operating voltage Deviation +/-8% |
| Reverse polarity protection of the supply voltage | Yes |
| Resistance to short-circuiting | Yes |
| Power consumption / operating (typ.) | 400 mA (@ 13.8 V) |
| Power consumption / operating (peak.) | < 2000 mA (@ 13.8 V) |
| Power consumption / standby | < 1 mA |
| Operating temperature | - 20 °C to + 60 °C |
| Storage temperature | - 20 °C to + 85 °C |
| Weight (ca.) | 415 g |
| Power Management | |
| Startup time from standby to full operation | < 35 s |
| Start of logging - starting from standby | CAN, LIN, Serial, Analog, Digital < 200 ms |
| Standby Mode | Configurable time without bus load |
| Wake | HS-CAN, LS-CAN, LIN, Serial, KL 15, [ON / Trigger] button |
| Data loss by power loss | If the device is switched off due to sudden power loss, up to 60 sec. of data may be lost. |
| Case | |
| Size (ca.) | 5.91" x 3.62" x 0.98" (150 x 92 x 25 mm) |
| Operating controls | Push-button to start and shut down data logger and to set markers |
| LEDs (STATE, ACTIVE) | STATE, ACTIVE |
| Connectors | |
| side connectors | 2x Gbit Ethernet SUB-D 26-pol: Power supply, 2x HS-CAN, 1x LS-CAN, 1x LIN, 2x Serial, 2x Analog In, 2x Digital In |
| Rear connectors | 4-pol audio jack plug stereo out/microphone (3.5 mm) OMTP Micro USB 2.0 SD card |
| Screen | |
| Size | 5" |
| Resolution | 800 x 480 |
| Colors | 16.7 million |
| Luminance | 700 cd/m ² |
| Touch function | Resistive, multi-touch |
| Data recording | |
| Storage type (internal) | 10 GB flash |
| Storage type (external) | USB flash drive SD card |
| Recording modes | Normal, ring buffer |
| Timestamp accuracy | 1 µs |
| CAN recording | |
| Channel | 2 High Speed, 1 Low Speed |
| Baud rate | Up to 1000000 Baud at HS-CAN up to 125000 Baud at LS-CAN |
| Transceiver | TJA1041A, TJA1055T |
| Filter | CAN ID filter |
| Status recording | Error frames |
| Serial recording | |
| Type | RS232 |

| | |
|-----------------------------|---|
| Channel | 2 |
| Baud rate | 1200, 2400, 4800, 9600, 19200, 38400, 57600, 115200 Baud |
| Data bits | 5,6,7,8 |
| Stop bits | 1,1.5,2 |
| Parity | None, odd, even |
| LIN recording | |
| Channel | 1 |
| Baud rate | 1200, 2400, 4800, 9600, 10400, 19200, 20000 Baud |
| Transceiver | TJA1021 |
| Ethernet recording | |
| Port | 2 |
| Speed | 2x 1 Gbit/s Protocol logging / 1 Gbit/s SPY-Mode) |
| Recording | GNLog, Raw, UTF8, UDP, DLT (optional), EsoTrace (optional) |
| Analog recording | |
| Channel | 1x Ubat (internal), 2x external |
| Range of measurement | Channel 1: 0V bis + 30V Channel 2/3: 0V bis + 20V |
| Resolution | 8 mV |
| Accuracy | 3 % 0 -16V 4 % 16 – 20 / 32V |
| Sampling interval | 1 ms to 100 s |
| Digital input | |
| Channel | 1x Ubat (internal), 2x external (physically identical with analog input) |
| Switching threshold | 7 V ± 0.2 V |
| Sampling interval | 1 ms to 100 s |
| | |

Table 10.1: Data sheet BLUEPIRAT Remote

11 Adapter cables & pinning

11.1 Remote Control Touch | Power supply

The power connection of the Remote Control Touch is similar to that of the Remote Control Voice. They are NOT identical. We therefore recommend to use the device-specific cable.

A power cable with LEMO connector to banana plug is required for the connection of the Remote Control Touch to the power supply.

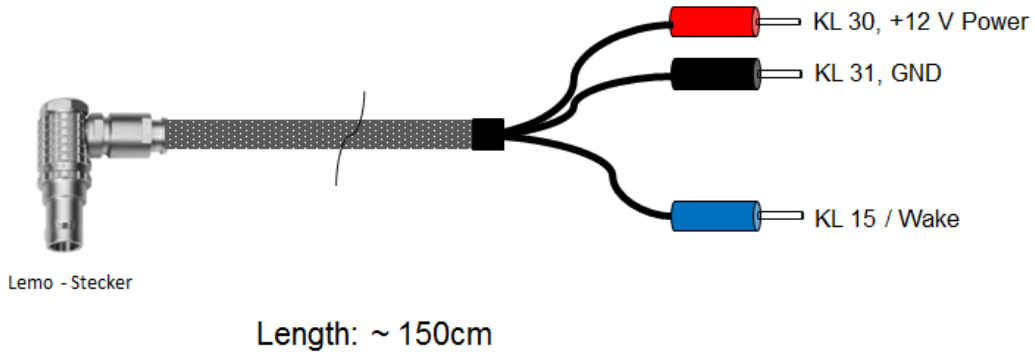

Figure 11.1: Power cable with LEMO connector to banana plug

Plug the LEMO connector into the Remote Control Touch and the banana plug into the power supply (**red/Vbat /+/Clamp 30** and **black/GND/-/Clamp 31**).

11.1.1 Remote Control Touch | Pinout of connector

As against to the Remote Control Voice, where the whole communication was send over this cable, the **Remote Control Touch** only uses this cable for power.

| Lmberg KV81-8 Pin(RCTouch) | Lemo Pin (cabel) | Bananaplug Pin | Signal |
|----------------------------|------------------|----------------|-------------------|
| 8 | 8 | blue | KL 15 (wake) |
| 6 | 7 | black | KL 31 (ground, -) |
| 7 | 2 | red | KL 30 (power, +) |

Table 11.1: Contacts of the angeled Lemo plug

11.1.2 Contacts of the Remote Control Touch connection

This drawing shows the pinout of the **Remote Control Touch** cable.

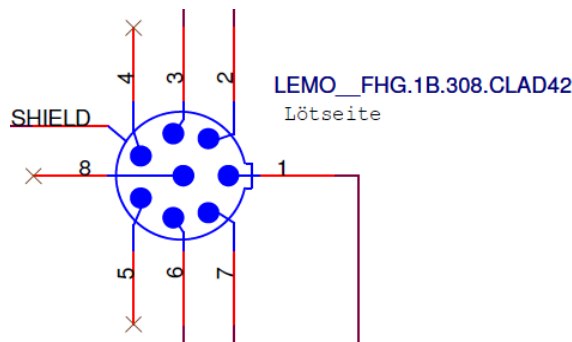

Figure 11.2: Pins of the angeled LEMO plug (FGH.1B.308.CLAD42) at the cable

11.2 BLUEPIRAT Remote | Power supply including cable set

A cable set with 26-pol SUB-D connector to banana plug is required for the connection of the **BLUEPIRAT Remote** to the power supply.

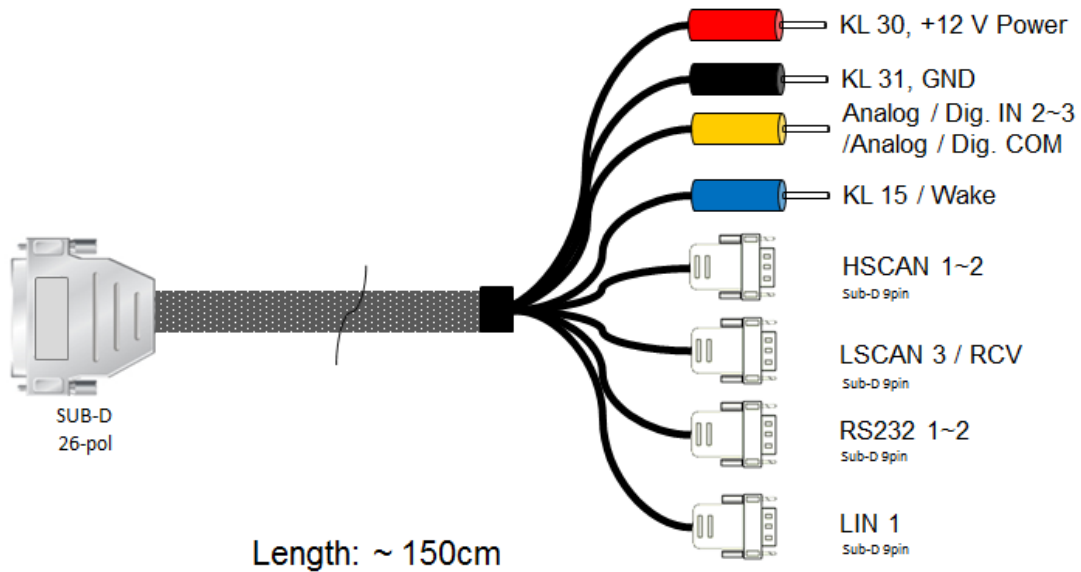

Figure 11.3: Power cable with 26-pol SUB-D connector to banana plug

Plug the 26-pol SUB-D connector into the **BLUEPIRAT Remote** and the banana plug into the power supply (**red/Vbat +/-Clamp 30** and **black/GND/-Clamp 31**).

11.2.1 BLUEPIRAT Remote | Pinout of connector

| @ Logger | | comment / depiction / signal name | @ Vehicle interface | |
|--------------|---------------------|-----------------------------------|---------------------------|-----|
| SUB-D 44-pol | Signal | | Type | Pin |
| 1 | KL15 | wake up from KL 15 | banana plug blue | 1 |
| 2 | HSCAN_L_0 | High Speed CAN #01 LOW | DSUB-9 / male | 2 |
| 3 | HSCAN_H_0 | High Speed CAN #01 HIGH | DSUB-9 / male | 7 |
| 4 | HSCAN_L_1 | High Speed CAN #02 LOW | DSUB-9 / male | 2 |
| 5 | HSCAN_H_1 | High Speed CAN #02 HIGH | DSUB-9 / male | 7 |
| 6 | LSCAN_L_0 | Low Speed CAN #03LOW | DSUB-9 / male | 2 |
| 7 | LSCAN_H_0 | Low Speed CAN #03 HIGH | DSUB-9 / male | 7 |
| 8 | n.c. | | | |
| 9 | KL31 | power supply (-) | banana plug black | 1 |
| 10 | KL31 | power supply (-) | combined with #9 | 1 |
| 11 | n.c. | | | |
| 12 | n.c. | | | |
| 13 | n.c. | | | |
| 14 | n.c. | | | |
| 15 | n.c. | | | |
| 16 | n.c. | | | |
| 17 | KL30 & -[Fuse 5 A]- | power supply (+) | banana plug red | 1 |
| 18 | KL30 | power supply (+) | combined with #17 | 1 |
| 19 | KFZ ANA / DIG COM | Analog / Dig. Interface ground | banana plug yellow | 1 |
| 20 | KFZ ANA IN 0 | Analog / Dig. Interface #2 IN | banana plug yellow | 1 |
| 21 | KFZ ANA IN 1 | Analog / Dig. Interface #3 IN | banana plug yellow | 1 |
| 22 | KFZ V24 RX 1 | Serial I RS232 #2 RX | DSUB-9 / male | 2 |
| 23 | KFZ V24 TX 1 | Serial RS232 #2 TX | DSUB-9 / male | 3 |
| 24 | KFZ V24 RX 0 | Serial RS232 #1 RX | DSUB-9 / male | 2 |
| 25 | KFZ V24 TX 0 | Serial RS232 #1 TX | DSUB-9 / male | 3 |
| 26 | LIN 0 | LIN 1 | DSUB-9 / male | 7 |

Table 11.2: Contacts of the 26-pol SUB-D plug of BLUEPIRAT Remote

11.3 RJ45 Ethernet connector

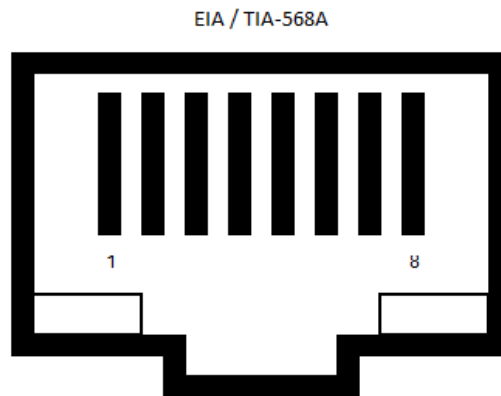

Figure 11.4: Pinout of RJ45 Ethernet connectors

| Pin | Signal |
|-----|--------|
| 1 | TX1+ |
| 2 | TX1- |
| 3 | TX2+ |
| 4 | TX3+ |
| 5 | TX3- |
| 6 | TX2- |
| 7 | TX4+ |
| 8 | TX4- |

Table 15.10: Pinout of the RJ45 connectors

12 Support

If problems occur with a product from Magna Telemotive GmbH, please take following steps:

- Read the User Manual
- Please check if you are using an up-to-date software
- Please check if all cables are correctly attached to the data logger
- If you are able to establish a connection to the data logger, run the program "Bug Reporter" in the System Client. This program creates a zip file, which you should please put into a ticket into our [OTRS Ticket system](#)
- Contact Customer Support at TMO.productsupport@magna.com (+49 89 357186-518)

12.1 Service Center

In our Service Center you will find the newest firmware versions and the latest version of the System Client as well as older versions for download. In addition, we offer detailed documentations and specifications for our current products.

There are two ways to reach the service center:

1. Using the current link:

<https://sc.telemotive.de/4/index.php?id=154&L=1>

2. Go to the Telemotive homepage and use the login link top right.

<http://www.telemotive.de>

Note: If you do not have an account for our service center and OTRS ticket system, please send a mail to TMO.Produktsupport@magna.com and we will generate an account for you.

12.2 OTRS Ticket system

With the login data for the service center you have access to our OTRS-Ticket system too. Every email sent to TMO.productsupport@magna.com generates automatically a ticket and can therefore be forwarded to the responsible person promptly.

At <https://produktsupport.telemotive.de> the status of your tickets can be checked fast and easily.

You can log in using your access data above. Creation of new tickets is also possible as upload an bugreport. The most important steps are described in a manual that can be found in the upper right corner of the website or under this link directly:

https://sc.telemotive.de/4/uploads/media/OTRS_Kurzanleitung.pdf

Note: If you want to upload more than 20 MB please create a ticket first and upload the file in a second step without the limitation.

12.2.1 What is OTRS?

The Open Ticket Request System (OTRS) of MAGNA Telemotive GmbH enables our customers to send inquiries and to report problems in a fast and easy way to our Customer Support, and to monitor these inquiries via a proprietary account. The personal login-area also offers the possibility to upload files to the corresponding inquiry.

12.2.2 Needed information in a ticket

If you notice any behavior with a MAGNA Telemotive GmbH product that does not correspond to the expected process, you are welcome to inform us via our ticket system.

Please report only one problem per ticket and do not create collective tickets to keep a clear overview.

In order to keep the processing time as short as possible for both sides, we would like to ask you to provide the following data when creating the ticket, so that the analysis can take place promptly.

12.2.2.1 Ticket | Checklist

- Observed behavior
- Exact time
- Used hardware
- Which system client / firmware version was used
- Location
- Reproducibility
- Last Steps
- Screenshots
- Error Report
- Offline data set

12.2.2.2 The points in detail

Observed behavior

What exactly have you observed that does not match the behavior you expected or described in the manual?

Exact time

The most accurate possible time when an unexpected behavior was observed.

Please always remember: Since we do not know which tests you are doing at what time, a concrete error time is absolutely necessary for the analysis. Without this information, an effective analysis is unfortunately not possible.

Used hardware

A list of the exact devices you were using when you observed the behavior. Is it a single device or a TSL group? If so, with which TSL participants and in which order are they connected?

Which system client / firmware version

Exact information about the version of the system client and the firmware used is also important, since it could possibly be a known problem in an older version. It is also important to specify whether you process data with the System Client, the Download Terminal or the ClientLib.

Location

Was the behavior observed in a vehicle or in a test system?

Reproducibility

Has the problem occurred once, or can it be reproduced with defined steps? Does the behavior occur with one or more setups?

Does the problem still occur after a restart and can it possibly be solved by a firmware update?

Last Steps

What was done last before this behavior was observed?

Screenshots

Screenshots can often explain something faster than words, so screenshots of the problem are always welcome to show or compare something. Especially for screenshots from your own tools please include an explanation of the values / representation.

Error report

An error report of the device / TSL network contains internal logs of the devices, the configuration, the error report of the system client with which the error report was created and optionally trace data. This combination helps us to understand what happened in the device at the specified time.

The creation of an error report is described in detail in the [User Manual of the System Client](#).

Offline data set

Especially if you have the feeling that something is wrong with the recording or conversion of the data, we also need an offline data set to be able to reproduce / analyze the problem.

The creation of an offline dataset is described in detail in the [User manual of the System Client](#).

12.2.3 Sending Inquiries

You can send inquiries as usual via your own email client to TMO.Productsupport@magna.com. This email arrives automatically the OTRS and generates a ticket. Furthermore you can write inquiries directly in the Open Ticket Request System (OTRS).

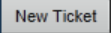
By clicking on the button  you can create a new ticket directly in your personal login-area at <https://produktsupport.telemotive.de>.

12.2.4 Login and Initial Steps

You can find the OTRS ticket system of Telemotive AG at <https://produktsupport.telemotive.de>.

There you can login to the OTRS using your access data, which you already use in the Service Center of MAGNA Telemotive GmbH.

After a successful login you will see a screen (see image 1), in which you can manage further activities.

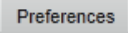

Figure 12.1: OTRS Ticket system

By clicking on the button  you can adjust language and view settings.

This screen also gives you an overview of your current tickets.

Shortly after the submission of an inquiry, you will find the corresponding ticket in your personal account.

If there is more than one ticket in your account, all tickets are listed by date.

You can see the content of the sent message by clicking on the corresponding ticket.

As soon as you receive a new message from the Customer Support, it will be shown in your personal login-area. In addition, you will receive an email.

12.2.5 Adding Files

You have different possibilities to add files to a ticket. You can add files, such as error reports or screenshots immediately when a new ticket is created by clicking on the button

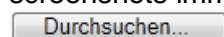

Warning:

There's a limitation up to 20 MB like in an e-mail. If you want to upload bigger files please upload these in the next step.

You can also upload an error report or trace files to your problem description afterwards.

By clicking on the button **Dateiupload / Fileupload** in the main screen of the login-area a new screen opens (see image 2).

With the button **Add files** you can choose your desired files for the upload. The upload can be started by using the button **Start upload**.

The upload of the file will be shown in your personal login-area.

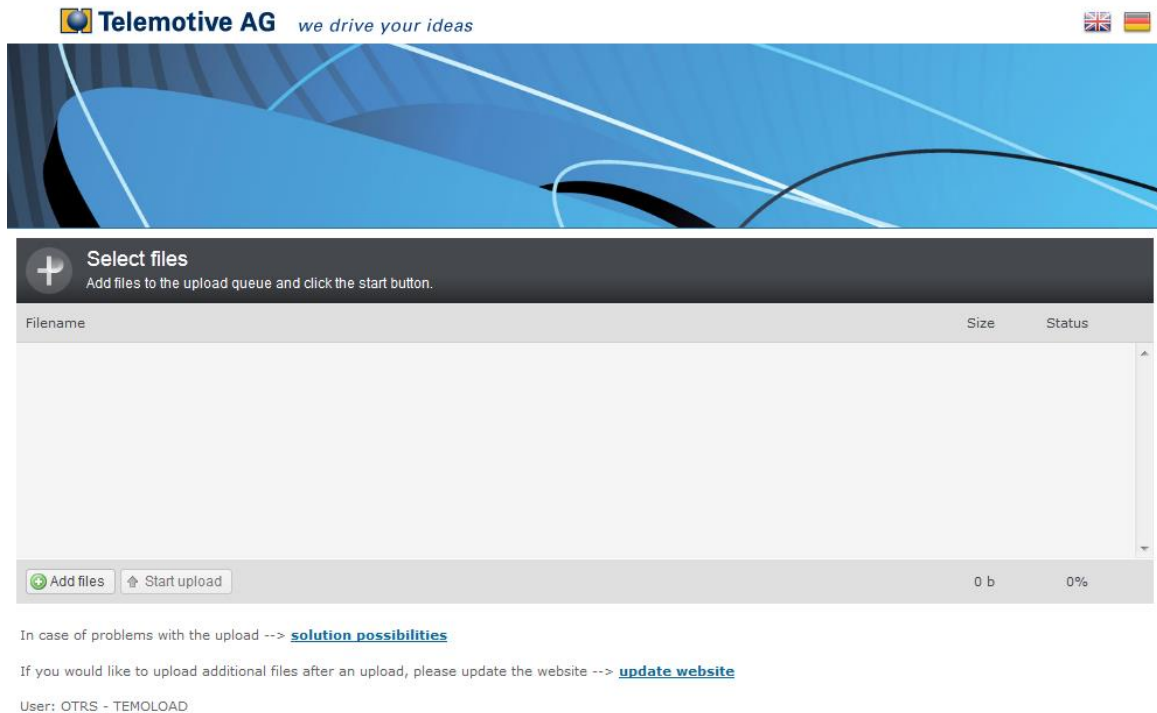

Figure 12.2:

12.2.6 Search Function

To search for a particular ticket, you can define your search criteria over the button **Search**. These criteria can be saved as a template.

12.2.7 Closing a ticket

In case that a problem description shall not be processed any longer, you can close the ticket yourself by clicking on the button **Reply** in the main screen of the login-area. Here you can change your status to “closed” and add a comment.

12.2.8 Contact

If you have any questions regarding the login or the procedure, please contact our Customer Support at TMO.Productsupport@magna.com.

12.3 Sending in defective devices

If your device needs to be return for repair, please complete the Service report for the device, print it out and send it with the defective device directly to Mühlhausen for repair.

12.3.1 Service report

The service report is available as Word and PFD file:

Word: [MagnaTelemotive-Servicereport.doc](#)

PDF: [MagnaTelemotive-Servicereport.pdf](#)

Note: Please note that no repair can be performed if the service report is missing or incomplete. A separate form is required for 'each' device!

12.3.2 Shipping address

Shipping address for repair devices:

MAGNA Telemotive GmbH
to. Repair Department
Industrie und Business Park
73347 Mühlhausen
-Germany-

- Please make sure to ship the package on the basis of DDP (Delivery Duty Paid) and that the total value of the loggers in the pro forma invoice is under 1000 euros.
- The logger will be analysed and, if it is still in warranty, repaired and shipped back to you. If the devices warranty is expired we will send you a quotation for the repair.
- Please note that in the case of rejected quotations, the costs for analysis, function test and shipping will be charged in form of a service charge of 205€ per data logger.
- If you need help with shipping due to the included batteries, please follow the instructions in our [BatteryGuide!](#)

Attention: On devices with internal memory the data will be deleted after the repair!

You can find this information as well on our website at
<https://sc.telemotive.de/4/en/servicecenter/faqs-support/support/>

12.3.3 Batteries:

If you need help with shipping due to the included batteries, please follow the instructions in our [BatteryGuide!](#)

(<https://sc.telemotive.de/4/fileadmin/bluepirat/support/BatteryGuide.pdf>)

12.4 Release info – informed just in time

With Magna Telemotive release info we will inform you about new firmware versions for our data loggers as soon as they are available. This allows you to keep your devices up to date with the latest state of development.

The notes about new features or fixed bugs can be found in the directly linked release notes.

By signing up you accept our [privacy policies](#). Opting out is possible at any time.

13 Abbreviations

| Kürzel / abbreviation | Bedeutung / meaning |
|-----------------------|---|
| blue PiraT | Processing Information Recording Analyzing Tool |
| bP | blue PiraT => BLUEPIRAT |
| bP2 | blue PiraT2 => BLUEPIRAT2 |
| bP2 5E | blue PiraT2 5E => BLUEPIRAT2 5E |
| bPMini | blue PiraT Mini => BLUEPIRAT Mini |
| RC Touch | Remote Control Touch |
| bP Remote | blue PiraT Remote => BLUEPIRAT Remote |
| bP Rapid | BLUEPIRAT Rapid |
| | |
| A2L | ASAM MCD-2 MC Language |
| AE | Automotive Electronics |
| ACK | ACKnowledged |
| CAN | Controller Area Network |
| CCP | CAN Calibration Protocol |
| CF | Compact Flash |
| CRO | Command Receive Object |
| | |
| DAQ | Data Acquisition |
| DTO | Data Transmission Object |
| | |
| ECL | Electrical Control Line |
| ECU | Electronic Control Unit |
| FIBEX | Field Bus Exchange Format |
| FW | Firmware |
| GMT | Greenwich Mean Time |
| INCA | INtegrated Calibration and Application Tool |
| | |
| LAN | Local Area Network = Netzwerk |
| LIN | Local Interconnect Network |
| | |
| MAC | M edia A ccess C ontrol |
| MCD | M easure C alibrate D iagnose |
| MDX | M eta D ata E Xchange Format |
| MEP | M OST Ethernet Packet |
| MOST | Media Oriented Systems Transport (www.mostnet.de) |
| | |
| ODT | O bject D escriptor T able |
| ODX | O pen D ata E Xchange |
| OEM | O riginal E quipment M anufacturer |
| | |
| PHY | PH YSical Bus Connect |
| PW | Passwort |
| RX | Receiver Data |
| | |
| SD | Secure Digital |
| SFTP | Secure File Transfer Protocol |
| SHA | Secure Hash |
| SSL | Secure Sockets Layer |
| | |
| TCP/IP | Transmission Control Protocol/Internet Protocol |
| TLS | Transport Layer Security |

| | |
|-------|---|
| tmt | Telemotive Trace |
| bPP | blue PiraT Packetformat |
| bPSA | blue PiraT System Access |
| bPSL | blue PiraT System Link |
| UDP | User Datagram Protocol |
| USB | Universal Serial Bus |
| UTC | Universal Time, Coordinated |
| | |
| Wi-Fi | W ireless F idelity |
| WLAN | W ireless L ocal A rea N etwork |
| | |
| XCP | Universal Measurement and Calibration Protocol |
| xtmt | eXtended Telemotive Trace |

Table 13.1: Abbreviations

14 List of figures

| | |
|---|----|
| Figure 4.1: links to the manuals in the System Client | 9 |
| Figure 5.1: Top view with operating elements..... | 12 |
| Figure 5.2: Side view, from the right with connectors..... | 13 |
| Figure 5.3: Rear side view with connectors | 13 |
| Figure 5.4: TSL network with one bPMini, one RCT and one bP2 (e.g.) | 18 |
| Figure 5.5: Client Portal..... | 19 |
| Figure 5.6: Desktop icon..... | 20 |
| Figure 5.7: Content of the portable client..... | 20 |
| Figure 5.8: Change IP settings | 21 |
| Figure 5.9: Automatic DHCP configuration for TSL..... | 22 |
| Figure 5.10: Viewing the devices in the client | 22 |
| Figure 5.11: Activating TSL | 23 |
| Figure 5.12: Representation of the TSL cluster in the client..... | 23 |
| Figure 5.13: Setting DigitalOut #2 to 1 | 25 |
| Figure 5.14: Wakeup on clamp 15 | 25 |
| Figure 5.15: Resetting DigitalOut #2 to 0 | 26 |
| Figure 5.16: Sampling interval of Analog input #1 | 26 |
| Figure 6.1: Application sitemap | 27 |
| Figure 6.2: Components of the application views..... | 28 |
| Figure 6.3: Unfolded page menu | 30 |
| Figure 6.4: Home view..... | 31 |
| Figure 6.5: Tab sheet "Overview" | 32 |
| Figure 6.6: Tab sheet "*Device name n*" | 33 |
| Figure 6.7: Device status with error message when memory runs out of space..... | 33 |
| Figure 6.8: Tab sheet "Function keys" | 34 |
| Figure 6.9: Tab sheet "Marker list" | 34 |
| Figure 6.10: Tab sheet "Notifications" | 35 |
| Figure 6.11: Tab sheet "Notifications": Memory fill level from 75 % | 35 |
| Figure 6.12: Tab sheet "Notifications": Memory fill level from 95 % | 35 |
| Figure 6.13: Tab sheet "Notifications": Download | 35 |
| Figure 6.14: Tab sheet "Notifications": Conversion | 35 |
| Figure 6.15: Tab sheet "Test drive" | 36 |
| Figure 6.16: Tab sheet "Test drive settings" | 36 |
| Figure 6.17: Test drive settings "Confirmation" | 36 |
| Figure 6.18: "Stop test drive" | 37 |
| Figure 6.19: Tab sheet "Shutdown" | 37 |
| Figure 6.20: Tab sheet "CAN" | 38 |
| Figure 6.21: Tab sheet "MOST150"..... | 39 |
| Figure 6.22: Tab sheet "MOST150": Light off | 39 |
| Figure 6.23: Tab sheet "GPS"..... | 40 |
| Figure 6.24: Tab sheet "GPS" – continuation..... | 40 |
| Figure 6.25: Tab sheet "GPS": No GPS signal | 41 |
| Figure 6.26: The view [Settings] => [General]..... | 41 |
| Figure 6.27: The view [Settings] => [Orientation] | 43 |
| Figure 6.28: Screen flipped at 180° | 43 |
| Figure 6.29: Overview of installed TSA modules | 44 |
| Figure 6.30: details of an installed TSA module..... | 44 |
| Figure 6.31: Camera Viewer: Camera overview | 45 |
| Figure 6.32: Camera Viewer: Axis F44 and pictures of 4 different cameras..... | 46 |
| Figure 6.33: Memory full note in the Status / overview display..... | 48 |
| Figure 6.34: Memory full-status in the detail view | 49 |
| Figure 6.35: FW-Update view | 50 |
| Figure 6.36: Popup in Launcher view | 51 |
| Figure 6.37: Window "RC Monitor" | 52 |
| Figure 6.38: Window "RC Text" | 53 |

| | |
|---|----|
| Figure 6.39: Standby view | 53 |
| Figure 6.40: Available applications for a data logger | 54 |
| Figure 6.41: Tab “Network Logger” in standalone mode | 55 |
| Figure 6.42: Configuration trees: Standalone mode (left) – TSL (right) | 56 |
| Figure 7.1: Fade-in after adjusting the brightness | 58 |
| Figure 7.2: Fade-in after adjusting the volume | 59 |
| Figure 7.3: Example side menu | 59 |
| Figure 7.4: Busload view with global trigger button | 60 |
| Figure 7.5: Marker popup in the Busload view | 60 |
| Figure 7.6: Voice note recording starts | 61 |
| Figure 7.7: Voice note recording starts | 61 |
| Figure 7.8: Voice note recording stops | 62 |
| Figure 7.9: Marker set | 62 |
| Figure 7.10: Voice note duration display | 63 |
| Figure 7.11: Tab “Firmware- / Licenses update” | 64 |
| Figure 7.12: Opening firmware-packet | 64 |
| Figure 7.13: Valid firmware-packet | 65 |
| Figure 7.14: Notice message for invalid firmware-packet | 65 |
| Figure 7.15: Notice message before firmware update | 65 |
| Figure 7.16: Advancing firmware update | 66 |
| Figure 11.1: Power cable with LEMO connector to banana plug | 73 |
| Figure 11.2: Pins of the angeled LEMO plug (FGH.1B.308.CLAD42) at the cable | 73 |
| Figure 11.3: Power cable with 26-pol SUB-D connector to banana plug | 74 |
| Figure 11.4: Pinout of RJ45 Ethernet connectors | 75 |
| Figure 12.1: OTRS Ticket system | 79 |
| Figure 12.2: | 80 |

[Index](#)

15 List of tables

| | |
|---|----|
| Table 4.1: Additional features by optional licenses | 10 |
| Table 5.1: Available connections | 14 |
| Table 5.2: LED behavior | 15 |
| Table 5.3: Compatible SD cards | 17 |
| Table 6.1: Application overview | 31 |
| Table 6.2: Message categories | 40 |
| Table 6.3: Operating elements of the tab sheet "General" | 42 |
| Table 6.4: Displays overview | 48 |
| Table 6.5: Device status messages | 48 |
| Table 9.1: Data sheet Remote Control Touch | 70 |
| Table 10.1: Data sheet BLUEPIRAT Remote | 72 |
| Table 11.1: Contacts of the angled Lemo plug | 73 |
| Table 11.2: Contacts of the 26-pol SUB-D plug of BLUEPIRAT Remote | 74 |
| Table 13.1: Abbreviations | 84 |

[Index](#)

16 Contact



DRIVING **EXCELLENCE.**
INSPIRING **INNOVATION.**

MAGNA Telemotive GmbH

Office München
Frankfurter Ring 115a
80807 München / Germany

Tel.: +49 89 357186-0
Fax.: +49 89 357186-520
E-Mail: TMO.info@magna.com
Web: www.telemotive.de

Sales
Tel.: +49 89 357186-550
Fax.: +49 89 357186-520
E-Mail: TMO.Sales@magna.com

Support
Tel.: +49 89 357186-518
E-Mail: TMO.productsupport@magna.com
ServiceCenter: <https://sc.telemotive.de/bluepirat>

© by MAGNA Telemotive GmbH

Subject to errors and to technical changes as part of product improvement.