



# blue PiraT Mini BroadR-Reach logging User Guide

Version 2.3.1 / 26.02.2016



## Table of contents

<b>1</b>	<b>LICENSE AGREEMENT .....</b>	<b>3</b>
<b>2</b>	<b>PRODUCT LIABILITY.....</b>	<b>4</b>
<b>3</b>	<b>Overview .....</b>	<b>5</b>
<b>4</b>	<b>System requirements .....</b>	<b>6</b>
	4.1 Manuals.....	6
<b>5</b>	<b>Activating BroadR-Reach logging.....</b>	<b>7</b>
	5.1 Switching the interface in the configuration.....	7
	5.2 Changing the interface .....	8
<b>6</b>	<b>Abbreviations .....</b>	<b>9</b>
<b>7</b>	<b>List of figures.....</b>	<b>10</b>
<b>8</b>	<b>List of tables .....</b>	<b>11</b>
<b>9</b>	<b>Contact.....</b>	<b>12</b>

# 1 LICENSE AGREEMENT

Please read the license agreement of this license contract carefully, before you install the software. By the installation of the software you agree to the conditions of this license contract. This software-license agreement, in the following called "license", contains all rights and restrictions for final users that regulate the use of the accompanying software, operating instructions and other documents, in the following called as "software".

1. This license contract is an agreement between licensor and licensee, who is being licensed to use the named software.
2. Licensee acknowledges that this is only a limited nonexclusive license. This means, that the licensee has no right to allocate sublicenses. Licensor is and remains the owner of all titles, rights and interests in the software.
3. The software is a copyright property of the Telemotive AG. The program or parts of it may not be further licensed to third parts, rented, sold or be further marketed in any form without explicit written approval by Telemotive AG. The user may neither change the software and their components, nor modify, nor redevelop or decompile otherwise in any form.
4. This software is subject to no warranty. This software is sold as is, without any warranty. If at any time, a user changes his system, we hold no responsibility to change our software to make it work again.
5. This license permits licensee to install the software on more than one computer system, as long as the software will not be used on more than one computer system simultaneously. Licensee will not make copies of the software or allow copies of the software to be made by others, unless authorized by this license agreement. Licensee may make copies of the software for backup purposes only. Licensee is not entitled to transmit or to transfer the software or its rights from this license agreement.
6. Licensor is not liable to licensee for any damages, including compensatory, special, incidental, exemplary, punitive or consequential damages, connected with or resulting from this license agreement or licensee's use of this software.
7. Licensee agrees to defend and indemnify licensor and hold licensor harmless from all claims, losses, damages, complaints or expenses connected with or resulting from licensee's business operations.
8. Licensor has the right to terminate this license agreement and licensee's right to use this software upon any material breach by licensee. The duration of the license contract is indefinitely determined.
9. Licensee agrees to return all copies of the software to licensor or to destroy them upon termination of the license contract.
10. This license agreement replaces and supersedes all prior negotiations, dealings and agreements between licensor and licensee regarding this software.
11. This license contract is subject to German law.
12. If a regulation of this license contract is void by law, the validity of the remaining regulations is not affected. If there is such a regulation it will be replaced by a valid, according to the legal regulations and enforceable regulation with similar intention and similar economic consequence.
13. The license contract is effective by delivery of the software of the licensor to the licensee and/or by usage of the software by the licensee. This license contract is also valid without licensor's signature.
14. The license automatically goes out if the licensee does not agree to the license regulations described here or offend against the license regulations of this license contract. With ending the license contract the licensee is obliged to extinguish or to destroy the software and all copies of it no matter if installed or stored on disk or to hand all of it back to Telemotive AG.
15. The licensee is liable for all damages caused to the licensor by the violation of these license regulations.

## 2 PRODUCT LIABILITY

For all offers, sales and supplies the following conditions apply exclusively, even if the buyer, orderer and suchlike prescribes other conditions. Alterations are only valid, if they are agreed in writing.

1. The technical documentation is part of the products. The product liability and the product guarantee will be excluded, if contents and in particular the safety references and instructions of the documentation are not considered.
2. The products do belong to the group of test tools. By application of the equipment a disturbance of the tested system cannot be completely excluded. For this reason, the warranty of a perfectly functioning system cannot be taken over by the manufacturer. Application of the product takes place at one's own risk.
3. The liability of the substitution of damages according to §1 product liability law is expressly excluded in the context of §9 product liability law, as far as compelling legal terms do not provide anything else.
4. In no event will the producer be liable for any indirect, incidental, special or consequential damages, including loss of profits, loss of revenues, loss of data, loss of use, any other economic advantage or damage caused by pretensions of third party towards the customer out of this agreement, under any theory of liability, whether in an action in contract, strict liability, tort (including negligence) or other legal or equitable theory.
5. The burden of proof is with the customer.
6. The Telemotive AG does ensure the legal warranty according to German law. Except for warranties expressly set forth in this agreement, any and all products are delivered "as is" and the producer makes and the customer receives no additional express or implied warranties. The producer hereby expressly disclaims any and all other warranties of any kind or nature concerning the products, whether express or implied, including without limitation, any warranty of title, merchantability, quality, accuracy or fitness for a particular purpose or the customer's purpose. The producer expressly disclaims any warranties that may be implied from usage of trade, course of dealing or course of performance. Except for the express warranties stated in this agreement the products are provided with all faults and the entire risk of unsatisfactory quality, performance, accuracy. The possible effort is with the customer. The producer does not warrant that the products will operate without interruption or be error free.
7. The Telemotive AG is justified to exchange defective goods against homogeneous acceptable ones or to eliminate the fault within an appropriate period. In this case a demand for redhibitory action or reduction of price expires. Warranty claims presuppose a due notice of defects.
8. Resale, transfer, donation, exchanges or the rental of the offered products at third party is permitted without clearance of the Telemotive AG.
9. German Law is deemed to be as legal basis.

### 3 Overview

This user guide describes the feature of the license **Broad-R-Reach** for the newest generation of Telemotive AG data logger, called **blue PiraT Mini**.

This user guide describes the configuration and usage of this feature. The general configuration is described in the user guides of the blue PiraT Mini as well as the Telemotive System Client.

The client software for blue PiraT Mini was only tested with Microsoft® Windows® 7.

This document refers to **blue PiraT Mini** firmware version 02.03.01 and the **Telemotive System Client** version 2.3.1. Some features depend on model and feature license or may not be available in older versions.

Software updates and user guides for other, optional, licensed enhancements are available in the Telemotive ServiceCenter. (*You will find the address under Contact*)

To ensure the most reliable operation of your system as possible, please make sure to use always current firmware and software versions.

[Index](#)

## 4 System requirements

### Control Unit

A Laptop or a PC is used to configure the devices by a software client. It also allows to save the recorded data and to use them offline.

### blue PiraT Mini

The **blue PiraT Mini** is the newest data logger developed by Telemotive AG. It is the smallest data logger with such high capacity and flexibility due to the possibility to combine several devices to one complex network.

The communication of bus systems and control units are monitored and relevant data can be recorded very precisely with the data loggers of the Telemotive AG. The collected data are stored on the data logger and can be downloaded via Ethernet and, e.g., analyzed on a test computer.

### Telemotive System Client

The software client is needed to configure the device and later to download or convert the recorded data.

### License

A license is required to use the **Broad-R-Reach** feature. All steps can be performed only with a valid license.

If you need an appropriate license for your product of the Telemotive AG, please contact our sales department. (*You will find the address under Contact*)

## 4.1 Manuals

Beside this user guide we offer the main manuals for our client as well as for the different data logger generations in our ServiceCenter at <https://sc.telemotive.de/bluepirat>.

### User manual for the Telemotive System Client

[https://sc.telemotive.de/4/uploads/media/TelemotiveSystemClient\\_UserManual.pdf](https://sc.telemotive.de/4/uploads/media/TelemotiveSystemClient_UserManual.pdf)

### User manual for blue PiraT Mini

[https://www.telemotive.de/4/uploads/media/blue\\_PiraT\\_Mini\\_UserManual.pdf](https://www.telemotive.de/4/uploads/media/blue_PiraT_Mini_UserManual.pdf)

Our licensed enhancements have own manuals which are stored in the ServiceCenter too. You will find a list of these enhancements in the user manuals in the chapter **Additional features by optional licenses**.

[Index](#)

## 5 Activating BroadR-Reach logging

**BroadR-Reach** is an Ethernet based standard, which allows multiple components of the electrical system of a vehicle to get access to information by using unshielded twisted pair wires simultaneously.

The **blue PiraT Mini** allows to disable the rear Ethernet ports **ETH #3** and **ETH #4** and activate the connectors **KFZ BRR 1** and **KFZ BRR 2** at the harness to be used for **BroadR-Reach**.

The changing to **BroadR-Reach logging** is done in the following two steps.

### 5.1 Switching the interface in the configuration

In the Telemotive System Client the needed interfaces are switched from RJ-45 to BroadR-Reach.

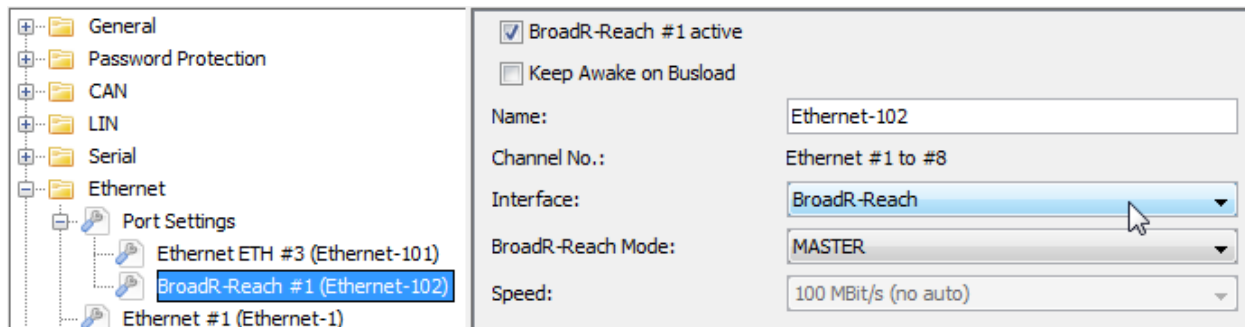

Figure 5.1: Activating BroadR-Reach

For a better clarity the name of the interface changes immediately in the overview. In this case ETH #3 is still configured to **RJ-45** and ETH #4 to **BroadR-Reach #1**.

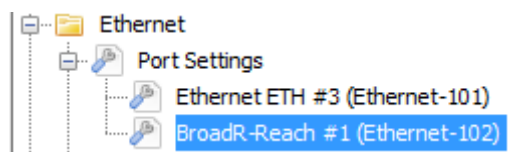

Figure 5.2: Changing of description

The **BroadR-Reach** interface can also operate in MASTER or SLAVE mode.

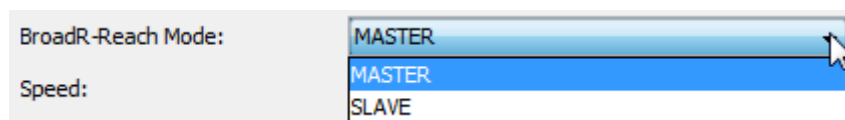

Figure 5.3: Selecting BroadR-Reach Mode

[Index](#)

Except for the transfer rate, which is fixed to 100 Mbit/s for BroadR-Reach, all settings inclusive the available filter options match to the settings for Ethernet logging.

A detailed description of all the settings for the Ethernet ports you will find in the User Guide of the Telemotive System Client.

## 5.2 Changing the interface

If one or both Ethernet interfaces are changed to **BroadR-Reach**, the Ethernet port on the device is disabled. But the **BroadR-Reach** connector on the wiring harness is enabled instead and must be used for the connection.

The BroadR-Reach interfaces are implemented to the wiring harness as black connectors and labeled with **KFZ BRR 1 / KFZ BRR 2**.

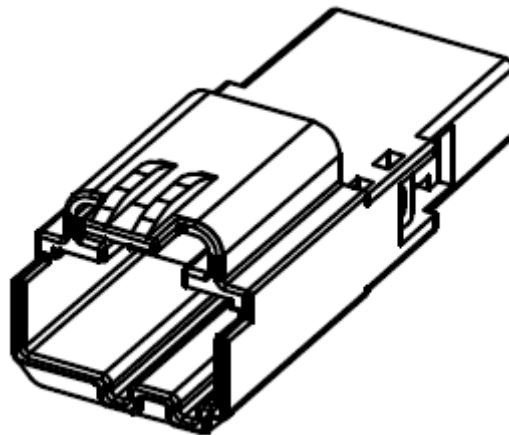

Figure 5.4: BroadR-Reach plug (Molex 310681010-series)

[Index](#)



## 6 Abbreviations

abbreviation	meaning
<b>blue PiraT</b>	<b>P</b> rocessing <b>I</b> nformation <b>R</b> ecording <b>A</b> nalyzing <b>T</b> ool
<b>bP</b>	<b>blue PiraT</b>
<b>bP2</b>	<b>blue PiraT2</b>
<b>bP2 HW2.x</b>	<b>blue PiraT2 Hardware 2.x</b>
<b>bPMini</b>	<b>blue PiraT Mini</b>
<b>TSL</b>	<b>T</b> elemotive <b>S</b> ystem <b>L</b> ink
<b>TSC</b>	<b>T</b> elemotive <b>S</b> ystem <b>C</b> lient
<b>CAN</b>	<b>C</b> ontroller <b>A</b> rea <b>N</b> etwork
<b>LIN</b>	<b>L</b> ocal <b>I</b> nterconnect <b>N</b> etwork
<b>MOST</b>	<b>M</b> edia <b>O</b> riented <b>S</b> ystems <b>T</b> ransport (www.mostnet.de)
<b>ECL</b>	<b>E</b> lectrical <b>C</b> ontrol <b>L</b> ine
<b>MEP</b>	<b>M</b> OST <b>E</b> thernet <b>P</b> acket
<b>USB</b>	<b>U</b> niversal <b>S</b> erial <b>B</b> us
<b>CF</b>	<b>C</b> ompact <b>F</b> lash
<b>SD</b>	<b>S</b> ecure <b>D</b> igital
<b>LAN</b>	<b>L</b> ocal <b>A</b> rea <b>N</b> etwork = Netzwerk
<b>FW</b>	<b>F</b> irmware
<b>PW</b>	<b>P</b> asswort
<b>SFTP</b>	<b>S</b> ecure <b>F</b> ile <b>T</b> ransfer <b>P</b> rotocol
<b>SHA</b>	<b>S</b> ecure <b>H</b> ash
<b>SSL</b>	<b>S</b> ecure <b>S</b> ockets <b>L</b> ayer
<b>TLS</b>	<b>T</b> ransport <b>L</b> ayer <b>S</b> ecurity
<b>TMP</b>	<b>T</b> elemotive <b>P</b> acketformat
<b>UTC</b>	<b>U</b> niversal <b>T</b> ime, <b>C</b> oordinated
<b>GMT</b>	<b>G</b> reenwich <b>M</b> ean <b>T</b> ime

**Table 6.1: Abbreviations**

[Index](#)

## 7 List of figures

Figure 5.1: Activating BroadR-Reach .....	7
Figure 5.2: Changing of description .....	7
Figure 5.3: Selecting BroadR-Reach Mode .....	7
Figure 5.4: BroadR-Reach plug (Molex 310681010-series) .....	8

[Index](#)

## 8 List of tables

Table 6.1: Abbreviations..... 9

[Index](#)

## 9 Contact



### Telemotive AG

Office München  
Frankfurter Ring 115a  
80807 München

Tel.: +49 89 357186-0  
Fax.: +49 89 357186-520  
E-Mail: [info@telemotive.de](mailto:info@telemotive.de)  
Web: [www.telemotive.de](http://www.telemotive.de)

Sales  
Tel.: +49 89 357186-550  
Fax.: +49 89 357186-520  
E-Mail: [sales@telemotive.de](mailto:sales@telemotive.de)

Support  
Tel.: +49 89 357186-518  
E-Mail: [productsupport@telemotive.de](mailto:productsupport@telemotive.de)  
ServiceCenter: <https://sc.telemotive.de/bluepirat>