



blue PiraT Mini BroadR-Reach logging User Guide

Version 3.0.1 / 13.04.2017

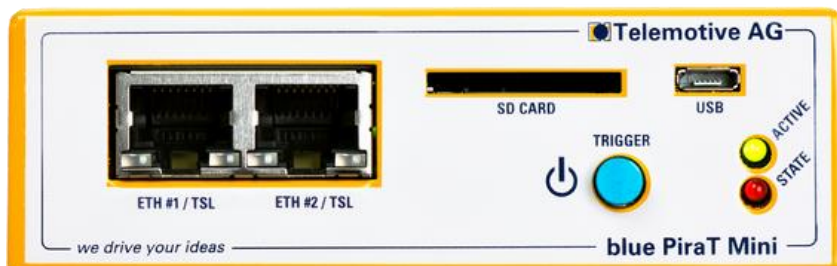

Table of contents

1	LICENSE AGREEMENT	3
2	PRODUCT LIABILITY.....	4
3	Overview	5
4	System requirements	6
	4.1 Further manuals	7
5	Activating BroadR-Reach logging.....	8
	5.1 Switching the interface in the configuration.....	8
	5.2 Changing the interface	9
6	Abbreviations	10
7	List of figures.....	12
8	List of tables	13
9	Contact.....	14

1 LICENSE AGREEMENT

Please read the license agreement of this license contract carefully, before you install the software. By the installation of the software you agree to the conditions of this license contract. This software-license agreement, in the following called "license", contains all rights and restrictions for final users that regulate the use of the accompanying software, operating instructions and other documents, in the following called as "software".

1. This license contract is an agreement between licensor and licensee, who is being licensed to use the named software.
2. Licensee acknowledges that this is only a limited nonexclusive license. This means, that the licensee has no right to allocate sublicenses. Licensor is and remains the owner of all titles, rights and interests in the software.
3. The software is a copyright property of the Telemotive AG. The program or parts of it may not be further licensed to third parts, rented, sold or be further marketed in any form without explicit written approval by Telemotive AG. The user may neither change the software and their components, nor modify, nor redevelop or decompile otherwise in any form.
4. This software is subject to no warranty. This software is sold as is, without any warranty. If at any time, a user changes his system, we hold no responsibility to change our software to make it work again.
5. This license permits licensee to install the software on more than one computer system, as long as the software will not be used on more than one computer system simultaneously. Licensee will not make copies of the software or allow copies of the software to be made by others, unless authorized by this license agreement. Licensee may make copies of the software for backup purposes only. Licensee is not entitled to transmit or to transfer the software or its rights from this license agreement.
6. Licensor is not liable to licensee for any damages, including compensatory, special, incidental, exemplary, punitive or consequential damages, connected with or resulting from this license agreement or licensee's use of this software.
7. Licensee agrees to defend and indemnify licensor and hold licensor harmless from all claims, losses, damages, complaints or expenses connected with or resulting from licensee's business operations.
8. Licensor has the right to terminate this license agreement and licensee's right to use this software upon any material breach by licensee. The duration of the license contract is indefinitely determined.
9. Licensee agrees to return all copies of the software to licensor or to destroy them upon termination of the license contract.
10. This license agreement replaces and supersedes all prior negotiations, dealings and agreements between licensor and licensee regarding this software.
11. This license contract is subject to German law.
12. If a regulation of this license contract is void by law, the validity of the remaining regulations is not affected. If there is such a regulation it will be replaced by a valid, according to the legal regulations and enforceable regulation with similar intention and similar economic consequence.
13. The license contract is effective by delivery of the software of the licensor to the licensee and/or by usage of the software by the licensee. This license contract is also valid without licensor's signature.
14. The license automatically goes out if the licensee does not agree to the license regulations described here or offend against the license regulations of this license contract. With ending the license contract the licensee is obliged to extinguish or to destroy the software and all copies of it no matter if installed or stored on disk or to hand all of it back to Telemotive AG.
15. The licensee is liable for all damages caused to the licensor by the violation of these license regulations.

2 PRODUCT LIABILITY

The General Terms and Conditions of Sale and Delivery of Telemotive AG can be found on our website at: [General Terms and Conditions of Sale and Delivery Telemotive AG.pdf](#)

3 Overview

This user guide describes the feature of the license **Broad-R-Reach** for the newest generation of Telemotive AG data logger, called **blue PiraT Mini**.

Broad-R-Reach is available for the CAN version of blue PiraT Mini only!

This user guide describes the configuration and usage of this feature. The general configuration is described in the user guides of the blue PiraT Mini as well as the Telemotive System Client.

This document refers to **blue PiraT Mini** firmware version 03.00.01 and the **Telemotive System Client** version 3.0.1. Some features depend on model and feature license or may not be available in older versions.

Software updates and user guides for other, optional, licensed enhancements are available in the Telemotive ServiceCenter. (*You will find the address under Contact*)

To ensure the most reliable operation of your system as possible, please make sure to use always current firmware and software versions.

[Index](#)

4 System requirements

Control Unit

A Windows based Laptop or PC is needed to configure the devices of Telemotive AG by **Telemotive System Client**. It also allows to save the recorded data and to use them offline later.

Telemotive System Client

The software client is used for configuring the data logger as well as downloading the recorded data or convert these into your needed file format. An firmware update can be performed by the **Telemotive System Client** too to ensure that your devices are always up to date.

blue PiraT2 / blue PiraT2 5E / blue PiraT Mini

The communication between bus systems and control units is monitored and relevant data can be recorded very precisely with the data logger of Telemotive AG. The collected data are stored to the logger and can be downloaded via Ethernet to a PC.

The **blue PiraT Mini** is smallest data logger in the world with an outstanding functional scope. It offers a wide range of interfaces, stable temperature behavior, very low energy consumption, four GBit Ethernet ports, and much more. Different blue PiraT Mini can be flexibly expanded to one cluster and therefore handled very easily by using [Telemotive System Link](#).

License

For the additional feature **Broad-R-Reach**, an installed license is required. Settings for licensed features can be performed with a valid license only.

If you need a license for your logger, please contact our sales department (please find the address under contact at the last page).

4.1 Further manuals

Beside this user guide we offer the main manuals for our client as well as for the different data logger generations in our ServiceCenter at <https://sc.telemotive.de/bluepirat>.

User manual for the Telemotive System Client

https://sc.telemotive.de/4/uploads/media/TelemotiveSystemClient_UserManual.pdf

User manual for blue PiraT2 / blue PiraT2 5E

https://www.telemotive.de/4/uploads/media/blue_PiraT2_UserManual.pdf

User manual for blue PiraT Mini

https://www.telemotive.de/4/uploads/media/blue_PiraT_Mini_UserManual.pdf

User manual for Remote Control Touch

https://sc.telemotive.de/4/uploads/media/RCTouch_UserGuide.pdf

User manual for blue PiraT Remote

https://sc.telemotive.de/4/uploads/media/blue_PiraT_Remote_UserGuide.pdf

For having an easy access if necessary, the most important manuals are linked in the client under the menu item **[Help]** and are reachable easily from there.

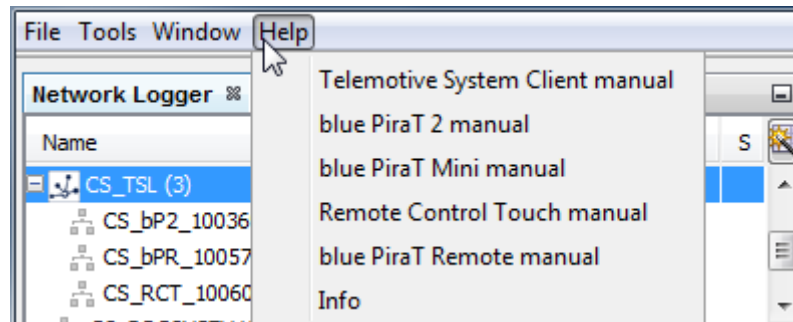

Figure 4.1: links to the manuals

Our licensed enhancements have own manuals which are stored in the ServiceCenter too. You will find a list of these enhancements in the user manuals in the chapter **Additional features by optional licenses**.

[Index](#)

5 Activating BroadR-Reach logging

BroadR-Reach is an Ethernet based standard, which allows multiple components of the electrical system of a vehicle to get access to information by using unshielded twisted pair wires simultaneously.

The **blue PiraT Mini CAN** allows to disable the rear Ethernet ports **ETH #3** and **ETH #4** and activate the connectors **KFZ BRR 1** and **KFZ BRR 2** at the harness to be used for **BroadR-Reach**.

The changing to **BroadR-Reach logging** is done in the following two steps.

5.1 Switching the interface in the configuration

In the Telemotive System Client the needed interfaces are switched from RJ-45 to BroadR-Reach.

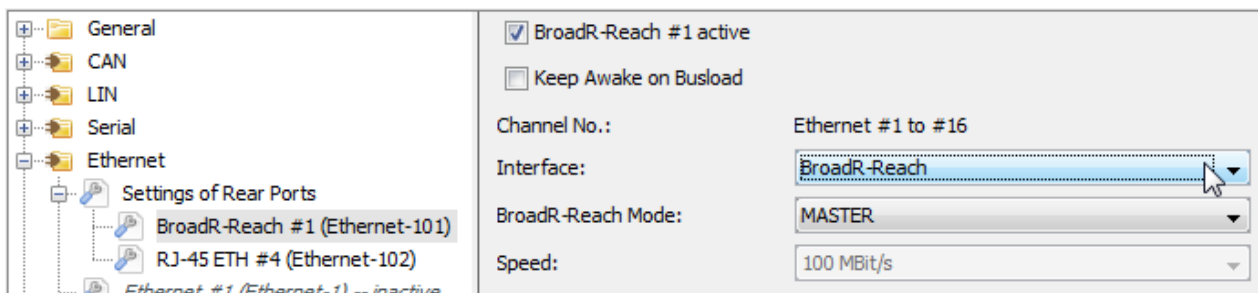

Figure 5.1: Activating BroadR-Reach

For a better clarity the name of the interface changes immediately in the overview. In this case ETH #3 to **BroadR-Reach #1** and ETH #4 is still configured to **RJ-45**.

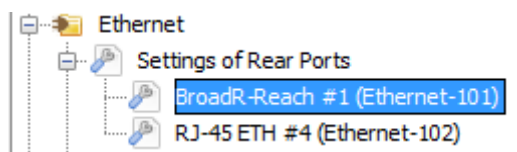

Figure 5.2: Changing of description

The **BroadR-Reach** interface can also operate in MASTER or SLAVE mode.

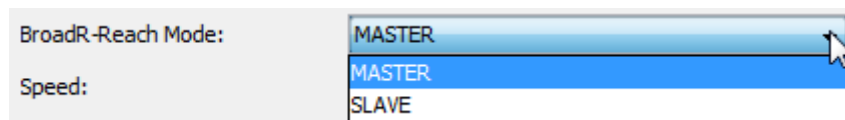

Figure 5.3: Selecting BroadR-Reach Mode

Except for the transfer rate, which is fixed to 100 Mbit/s for BroadR-Reach, all settings inclusive the available filter options match to the settings for Ethernet logging.

A detailed description of all the settings for the Ethernet ports you will find in the User Guide of the Telemotive System Client.

Speed: Autonegotiation is not performed, fixed configuration to 100 Mbit/s

5.2 Changing the interface

If one or both Ethernet interfaces are changed to **BroadR-Reach**, the Ethernet port on the device is disabled. But the **BroadR-Reach** connector on the wiring harness is enabled instead and must be used for the connection.

The BroadR-Reach interfaces are implemented to the wiring harness as black connectors and labeled with **KFZ BRR 1 / KFZ BRR 2**.

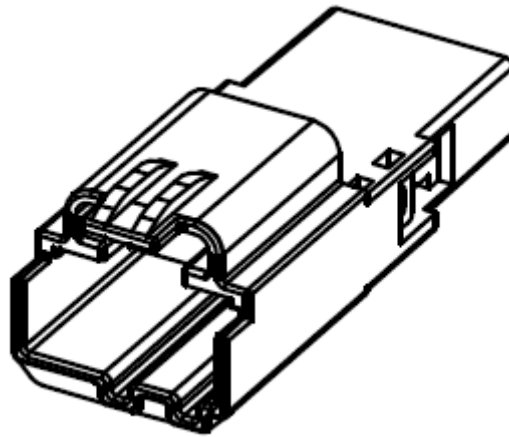

Figure 5.4: BroadR-Reach plug (Molex 310681010-series)

[Index](#)

6 Abbreviations

Kürzel / abbreviation	Bedeutung / meaning
blue PiraT	P rocessing I nformation R ecording A nalyzing T ool
bP	blue PiraT
bP2	blue PiraT2
bP2 5E	blue PiraT2 5E
bPMini	blue PiraT Mini
RC Touch	R emote C ontrol T ouch
bP Remote	blue PiraT Remote
A2L	A SAM M CD-2 M C L anguage
AE	A utomotive E lectronics
ACK	A C K nowledged
CAN	C ontroller A rea N etwork
CCP	C AN C alibration P rotocol
CF	C ompact F lash
CRO	C ommand R eceive O bject
DAQ	D ata A cquisition
DTO	D ata T ransmission O bject
ECL	E lectrical C ontrol L ine
ECU	E lectronic C ontrol U nit
FIBEX	F ield B us E xchange F ormat
FW	F irmware
GMT	G reenwich M ean T ime
INCA	I N T egrated C alibration and A pplication T ool
LAN	L ocal A rea N etwork = Netzwerk
LIN	L ocal I nterconnect N etwork
MAC	M edia A ccess C ontrol
MCD	M easure C alibrate D iagnose
MDX	M eta D ata E Xchange F ormat
MEP	M OST E thernet P acket
MOST	M edia O riented S ystems T ransport (www.mostnet.de)
ODT	O bject D escriptor T able
ODX	O pen D ata E Xchange
OEM	O riginal E quipment M anufacturer

PHY	PHY sical Bus Connect
PW	Pass wort
RX	Recei ver Data
SD	Secure Digital
SFTP	Secure File Transfer Protocol
SHA	Secure Hash
SSL	Secure Sockets Layer
TCP/IP	Trans mission Control Protocol/ Inter net Protocol
TLS	Trans port Layer Security
TMP	Telemotive Packetformat
TSL	Telemotive System Link
UDP	User Datagram Protocol
USB	Un iversal Serial Bus
UTC	Un iversal Time, Co ordinated
Wi-Fi	Wire less Fidelity
WLAN	Wire less Local Area Network
XCP	Un iversal Measurement and Cal ibration Protocol

Table 6.1: Abbreviations
[Index](#)

7 List of figures

Figure 4.1: links to the manuals	7
Figure 5.1: Activating BroadR-Reach	8
Figure 5.2: Changing of description	8
Figure 5.3: Selecting BroadR-Reach Mode	8
Figure 5.4: BroadR-Reach plug (Molex 310681010-series)	9

[Index](#)

8 List of tables

Table 6.1: Abbreviations..... 11

[Index](#)

9 Contact



Telemotive AG

Office München
Frankfurter Ring 115a
80807 München

Tel.: +49 89 357186-0
Fax.: +49 89 357186-520
E-Mail: info@telemotive.de
Web: www.telemotive.de

Sales
Tel.: +49 89 357186-550
Fax.: +49 89 357186-520
E-Mail: sales@telemotive.de

Support
Tel.: +49 89 357186-518
E-Mail: productsupport@telemotive.de
ServiceCenter: <https://sc.telemotive.de/bluepirat>

© by Telemotive AG, 2016
Subject to errors and to technical changes as part of product improvement.