



blue PiraT2 / 5E User Guide

Version 3.0.1 / 21.12.2016



Table of contents

1	LICENSE AGREEMENT	4
2	PRODUCT LIABILITY.....	5
3	Overview	6
4	System requirements	7
4.1	Further manuals	8
4.2	Additional features by optional licenses	9
5	The blue PiraT2 system.....	10
5.1	Accessories.....	10
5.2	Model versions of blue PiraT2 / blue PiraT2 5E.....	11
6	Control elements at the front side.....	12
6.1	ON / Trigger button.....	13
6.1.1	Resetting the network settings.....	13
6.2	OFF / Esc button	13
6.3	Status LEDs	13
6.4	External storage	14
6.4.1	Compact Flash card (CF)	14
6.4.2	USB storage.....	15
6.5	Menu knob	15
6.6	Display	15
6.6.1	Startup	16
6.6.2	Menu mode	16
6.6.3	Info.....	17
6.6.4	Licenses.....	17
6.6.5	Functions.....	17
6.6.6	Error Memory	17
6.6.7	Memory Device	18
6.6.7.1	Copy to memory device	18
6.6.7.2	Erase memory device	18
6.6.7.3	Format memory device	18
6.6.7.4	Install license	18
6.6.7.5	Create bug report.....	19
6.6.7.6	Firmware update	19
6.6.7.7	Install configuration	19
6.6.7.8	Safely remove ext. Mem.....	20
7	Starting the blue PiraT2	21
7.1	Download and installation of the Telemotive System Client.....	23
7.2	Interfaces at the rear side	25
8	Adapter cables.....	27
8.1	Universal adapter cable.....	27
8.2	Power cable for blue PiraT2 5E (Art. 103 614).....	27
8.3	Adapter cable Serial/RS232, Analog/Digital.....	28
8.4	Adapter cables for Analog/Digital.....	29
8.5	Adapter cable FlexRay	29
8.6	Adapter cables for CAN/FlexRay.....	29
8.7	Adapter cable for Remote Control Voice (RCV).....	30
8.8	Ethernet kit for blue PiraT2.....	30
9	Logging data.....	31
9.1	Setting markers	31
9.1.1	Setting marker with an extern push button.....	31
9.2	Time stamp	32
9.3	Standby mode	33
9.4	Memory space and level.....	34

9.4.1	Status Logger: OK.....	34
9.4.2	Status Logger: WARN.....	34
9.4.3	Status Logger: RING.....	34
9.4.4	Status Logger: MEM.....	35
9.4.5	Status Logger: ERROR.....	36
10	Interfaces	37
10.1	CAN.....	37
10.1.1	High Speed and Low Speed operating modes.....	37
10.1.2	CAN data with 29 Bit identifiers.....	37
10.1.3	Recording contents.....	38
10.1.4	Sending CAN messages.....	38
10.2	LIN 39.....	
10.2.1	LIN data blocks and time stamps.....	39
10.2.2	LIN transceiver.....	39
10.2.3	Special frames and states.....	39
10.3	Serial (RS232).....	40
10.3.1	Segmentation of the serial data.....	40
10.3.2	RS232 transceiver.....	40
10.4	FlexRay.....	40
10.5	Ethernet.....	41
10.5.1	GNLogger.....	41
10.5.2	UTF8.....	41
10.5.3	Raw.....	41
10.5.4	UDPServer.....	41
10.5.5	TCPServer.....	42
10.5.6	SpyMode.....	42
10.5.7	EsoTrace.....	42
10.5.8	Camera (license required).....	42
10.5.9	DLT (license required).....	42
10.6	MOST25.....	43
10.7	MOST150.....	43
10.8	ECL.....	44
11	Conversion of recorded traces.....	45
11.1	Conversion format overview.....	45
12	Service and safety instructions.....	46
12.1	Safety advice.....	46
13	Data sheet.....	48
14	Pin assignments and harnesses.....	52
14.1	Data logger: Multi function connector.....	54
14.1.1	Pin assignment of the blue PiraT2 multi-function connector.....	54
14.1.2	Pin assignment of the blue PiraT2 5E multi-function connector.....	56
14.2	blue PiraT2 5E – power harness.....	58
14.3	Serial connector (D-Sub 26).....	59
14.4	Analog/Digital connector (26-pin) (not at 14C6S8L).....	60
14.5	Ethernet connector.....	61
14.6	FlexRay connector.....	62
14.7	CAN/FlexRay (D-Sub 44) (25M24C8LFR only).....	63
14.7.1	Connection to Remote Control Voice.....	65
14.7.2	Contacts of the Remote Control Voice cable.....	66
14.8	Pinning of the FCI connector for the Ethernet-Kit.....	66
15	Abbreviations.....	67
16	List of figures.....	69
17	List of tables.....	70
18	Contact.....	71

1 LICENSE AGREEMENT

Please read the license agreement of this license contract carefully, before you install the software. By the installation of the software you agree to the conditions of this license contract. This software-license agreement, in the following called "license", contains all rights and restrictions for final users that regulate the use of the accompanying software, operating instructions and other documents, in the following called as "software".

1. This license contract is an agreement between licensor and licensee, who is being licensed to use the named software.
2. Licensee acknowledges that this is only a limited nonexclusive license. This means, that the licensee has no right to allocate sublicenses. Licensor is and remains the owner of all titles, rights and interests in the software.
3. The software is a copyright property of the Telemotive AG. The program or parts of it may not be further licensed to third parts, rented, sold or be further marketed in any form without explicit written approval by Telemotive AG. The user may neither change the software and their components, nor modify, nor redevelop or decompile otherwise in any form.
4. This software is subject to no warranty. This software is sold as is, without any warranty. If at any time, a user changes his system, we hold no responsibility to change our software to make it work again.
5. This license permits licensee to install the software on more than one computer system, as long as the software will not be used on more than one computer system simultaneously. Licensee will not make copies of the software or allow copies of the software to be made by others, unless authorized by this license agreement. Licensee may make copies of the software for backup purposes only. Licensee is not entitled to transmit or to transfer the software or its rights from this license agreement.
6. Licensor is not liable to licensee for any damages, including compensatory, special, incidental, exemplary, punitive or consequential damages, connected with or resulting from this license agreement or licensee's use of this software.
7. Licensee agrees to defend and indemnify licensor and hold licensor harmless from all claims, losses, damages, complaints or expenses connected with or resulting from licensee's business operations.
8. Licensor has the right to terminate this license agreement and licensee's right to use this software upon any material breach by licensee. The duration of the license contract is indefinitely determined.
9. Licensee agrees to return all copies of the software to licensor or to destroy them upon termination of the license contract.
10. This license agreement replaces and supersedes all prior negotiations, dealings and agreements between licensor and licensee regarding this software.
11. This license contract is subject to German law.
12. If a regulation of this license contract is void by law, the validity of the remaining regulations is not affected. If there is such a regulation it will be replaced by a valid, according to the legal regulations and enforceable regulation with similar intention and similar economic consequence.
13. The license contract is effective by delivery of the software of the licensor to the licensee and/or by usage of the software by the licensee. This license contract is also valid without licensor's signature.
14. The license automatically goes out if the licensee does not agree to the license regulations described here or offend against the license regulations of this license contract. With ending the license contract the licensee is obliged to extinguish or to destroy the software and all copies of it no matter if installed or stored on disk or to hand all of it back to Telemotive AG.
15. The licensee is liable for all damages caused to the licensor by the violation of these license regulations.

2 PRODUCT LIABILITY

For all offers, sales and supplies the following conditions apply exclusively, even if the buyer, orderer and suchlike prescribes other conditions. Alterations are only valid, if they are agreed in writing.

1. The technical documentation is part of the products. The product liability and the product guarantee will be excluded, if contents and in particular the safety references and instructions of the documentation are not considered.
2. The products do belong to the group of test tools. By application of the equipment a disturbance of the tested system cannot be completely excluded. For this reason, the warranty of a perfectly functioning system cannot be taken over by the manufacturer. Application of the product takes place at one's own risk.
3. The liability of the substitution of damages according to §1 product liability law is expressly excluded in the context of §9 product liability law, as far as compelling legal terms do not provide anything else.
4. In no event will the producer be liable for any indirect, incidental, special or consequential damages, including loss of profits, loss of revenues, loss of data, loss of use, any other economic advantage or damage caused by pretensions of third party towards the customer out of this agreement, under any theory of liability, whether in an action in contract, strict liability, tort (including negligence) or other legal or equitable theory.
5. The burden of proof is with the customer.
6. The Telemotive AG does ensure the legal warranty according to German law. Except for warranties expressly set forth in this agreement, any and all products are delivered "as is" and the producer makes and the customer receives no additional express or implied warranties. The producer hereby expressly disclaims any and all other warranties of any kind or nature concerning the products, whether express or implied, including without limitation, any warranty of title, merchantability, quality, accuracy or fitness for a particular purpose or the customer's purpose. The producer expressly disclaims any warranties that may be implied from usage of trade, course of dealing or course of performance. Except for the express warranties stated in this agreement the products are provided with all faults and the entire risk of unsatisfactory quality, performance, accuracy. The possible effort is with the customer. The producer does not warrant that the products will operate without interruption or be error free.
7. The Telemotive AG is justified to exchange defective goods against homogeneous acceptable ones or to eliminate the fault within an appropriate period. In this case a demand for redhibitory action or reduction of price expires. Warranty claims presuppose a due notice of defects.
8. Resale, transfer, donation, exchanges or the rental of the offered products at third party is permitted without clearance of the Telemotive AG.
9. German Law is deemed to be as legal basis.

3 Overview

This user guide describes the administration of the second generation of blue PiraT data logger of the Telemotive AG, called **blue PiraT2**, as well as for the newest, for Ethernet recording optimized generation, the **blue PiraT2 5E**.

In all functions which are equal to both devices we use the name **blue PiraT2** in this user guide. If there are differences in the handling they are mentioned separately.

This user guide describes hardware and interfaces as well as the general functions of the **blue PiraT2 / blue PiraT2 5E**. The configuration and converting of the logged traces is described in the user guide of the **Telemotive System Client**.

This document refers to **firmware version 03.00.01** and the **Telemotive System Client** from **version 3.0.1**. Some features depending on model and feature license or may not be available in older versions.

Software updates and user guides for other, optional, licensed enhancements are available in the Telemotive ServiceCenter. *(Please find the address under Contact at the last page.)*

To ensure the most reliable operation of your system as possible, please make sure to use always current firmware and software versions.

[Index](#)

4 System requirements

Control Unit

A Windows based Laptop or PC is needed to configure the devices of Telemotive AG by **Telemotive System Client**. It also allows to save the recorded data and to use them offline later.

Telemotive System Client

The software client is used for configuring the data logger as well as downloading the recorded data or convert these into your needed file format. An firmware update can be performed by the **Telemotive System Client** too to ensure that your devices are always up to date.

blue PiraT2 / blue PiraT2 5E

The communication between bus systems and control units is monitored and relevant data can be recorded very precisely with the data logger of Telemotive AG. The collected data are stored to the logger and can be downloaded via Ethernet to a PC.

The **blue PiraT2** is our top-class all-in-one data logger. Seven models cover a wide range of interfaces.

Additionally, the **blue PiraT2 5E** offers improved power management and power backup, five integrated Ethernet ports and super-fast start-up behavior. The blue PiraT2 can be flexibly expanded via [Telemotive System Link](#).

Remote Control Touch (optional)

Operate your blue PiraT Mini or blue PiraT2 data loggers safely and comfortably from the driver's or passenger seat. Via Telemotive System Link our new remote control becomes part of your logger network. One remote control can handle all connected loggers.

blue PiraT Remote (optional)

While Remote Control Touch is just a control unit for handling unique devices or a TSL network, the blue PiraT Remote additional has logger functionality by offering internal storage and some interfaces.

License

For some additional features an installed license is required. Settings for licensed features can be performed with a valid license only.

If you need a license for your logger, please contact our sales department (please find the address under contact at the last page).

4.1 Further manuals

Beside this user guide we offer the main manuals for our client as well as for the different data logger generations in our ServiceCenter at <https://sc.telemotive.de/bluepirat>.

User manual for the Telemotive System Client

https://sc.telemotive.de/4/uploads/media/TelemotiveSystemClient_UserManual.pdf

User manual for blue PiraT2 / blue PiraT2 5E

https://www.telemotive.de/4/uploads/media/blue_PiraT2_UserManual.pdf

User manual for blue PiraT Mini

https://www.telemotive.de/4/uploads/media/blue_PiraT_Mini_UserManual.pdf

User manual for Remote Control Touch

https://sc.telemotive.de/4/uploads/media/RCTouch_UserGuide.pdf

User manual for blue PiraT Remote

https://sc.telemotive.de/4/uploads/media/blue_PiraT_Remote_UserGuide.pdf

For having an easy access if necessary, the most important manuals are linked in the client under the menu item **[Help]** and are reachable easily from there.

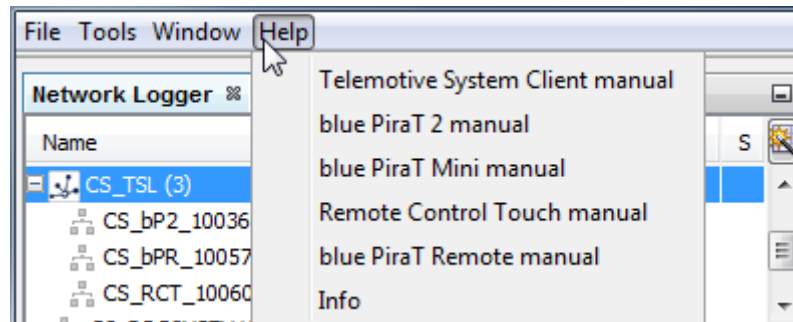

Figure 4.1: links to the manuals

Our licensed enhancements have own manuals which are stored in the ServiceCenter too. You will find a list of these enhancements in the user manuals in the chapter **Additional features by optional licenses**.

[Index](#)

4.2 Additional features by optional licenses

Additional features can be activated by purchasing and installing licenses. Licenses can be ordered at our sales team. You find the user guides for these additional features in the Telemotive ServiceCenter. Currently the following licensed features are available.

Feature	Description
Complex Triggers	Certain events (e.g., conditions on CAN-signals) can be programmed to be a trigger for certain actions (e.g., display of a message on the Remote Control or send a CAN message). The standard configuration of the data logger contains 2 complex triggers. This license allows configuring up to 50 complex triggers.
Remote Control Monitor	display of configurable CAN, LIN, FlexRay, analog and digital signals at the Remote Control
Diagnostic Log and Trace	logging of Diagnostic Log and Trace (DLT) messages over Ethernet or serial (restricted) connections
Camera Link	video recording via video server or network cameras
WLAN	supporting wireless LAN (802.11, 802.11a, 802.11n), (802.11ac from FW 02.04.01)
GPS logging	tracking of GPS data
Measurements with CCP	CAN Calibration Protocol
Measurements with XCP	Universal Measurement and Calibration Protocol Currently the functionality for Ethernet (XCP on Ethernet) and the CAN-bus (XCP on CAN) are available.
MOST150 Streaming	logging MOST150 synchronous/isochronous data
Signal Based Filtering	The feature Signal Based Filtering provides the possibility to extract pre-configured signals directly from the recorded CAN, LIN, FlexRay, analog and digital messages with an adjustable sampling frequency. These filtered signals can be stored directly to the logger and extract automatically in a MDF, CSV or TMT file.
Telemotive Live View	showing CAN signals in a HTML-5 compatible browser on mobile devices like smartphones, tablets or laptops over Wi-Fi (licensed feature) or Ethernet The enhanced version has no limitation to mobile devices or signals which can be shown.
BroadR-Reach logging	recording of data over BroadR-Reach Ethernet. (Note: Just available for blue PiraT Mini)
MLBevo	The license Connected-Gateway MLBevo enables the recording of data of the ATOP control unit MLBevo via USB to the Telemotive data logger and convert these data with the Telemotive System Client. (from FW 02.03.01)
Telemotive Download Terminal	Telemotive Download Terminal allows an automatization of configured tasks for a defined group of devices. (from FW 02.03.01)
TPE	TPE = Telemotive Performance Extension Increasing the logging rate for Ethernet data up to 100Mbit/s (from FW 02.04.01)
Test automatisaton	Interface for connecting to test automation tools. At the moment, the sending of CAN messages is supported. (from FW 02.04.01)

Table 4.1: Additional features by optional licenses

5 The blue PiraT2 system

The **blue PiraT2 / blue PiraT2 5E** is a data logger for the following interfaces:



Figure 5.1: Interface (overview)

The data logger can be mounted in a vehicle and due to his large storage capacity of the hard drive of currently 100 GB or higher, the **blue PiraT2** is able to support extensive test runs. After the data has been gathered it has to be downloaded via Ethernet. For the download and the conversion of the logging data the Telemotive System Client is available.

For the available conversion options to various trace file formats please have a look at chapter Fehler! Verweisquelle konnte nicht gefunden werden. Fehler! Verweisquelle konnte nicht gefunden werden.. The blue PiraT2 is available with different features (see chapter 5.2).

The blue PiraT2 is designed to create minimum interference with the vehicle's bus systems and interfaces. The data logger listens to the data traffic without operating as a bus node.

Additionally to the data recording functionality, the blue PiraT2 provides online data processing functions:

- simple CAN- and MOST-filters
- custom-defined messages can trigger the setting of markers

5.1 Accessories

There are various accessories available for the **blue PiraT2 / blue PiraT2 5E** data logger:

- various adapter cables
- the Remote Control Voice, which additionally allows recording of voice note
- licenses which enhance the functionality of the blue PiraT2
- mounting bracket

Please contact Telemotive sales for more information about these accessories.

Manuals are available from the Telemotive ServiceCenter.

[Index](#)

5.2 Model versions of blue PiraT2 / blue PiraT2 5E

The blue PiraT2 supports a lot of bus systems which can be recorded by the data logger. This table shows which model of the blue PiraT2 supports which number of interfaces and channels.

Schnittstelle / Interface																
	MOST150 cPhy	MOST150 (150M)	MOST25 (25M)	ECL	HS-CAN (C)	LS-CAN (C)	RC I/F	LIN (L)	FlexRay a/b (FR)	RS232	Digital In	Digital Out	Analog In	USB	1 Gbit Ethernet	100 Mbit Ethernet
blue PiraT2																
14C6S8L	-	-	-	-	12	2	1	8	-	6	1	1	2	3	1	4
25M24C8LFR	-	-	1	-	22	2	1	8	2	6	5	3	10	3	1	4
150M14C8LFR	-	1	-	1	12	2	1	8	2	6	5	3	10	3	1	4
blue PiraT2 5E																
14C5E6S	-	-	-	-	12	2	1	8	-	6	1	1	2	2	5	-
25M5E24C	-	-	1	-	22	2	1	8	2	6	5	3	10	2	5	-
150M5E14C	-	1	-	1	12	2	1	8	2	6	5	3	10	2	5	-
150M5E14C cPhy	1	-	-	1	12	2	1	8	2	6	5	3	10	2	5	-

Table 5.1: Model versions of blue PiraT2 / blue PiraT2 5E

The model name gives a hint to the integrated interfaces, e.g., blue PiraT2 150M14C8LFR: 1x MOST150, 12x HS-CAN, 2x LS-CAN, 8x LIN, 2x FlexRay a/b, 1x 1-Gbit-Ethernet and 4x 100-Mbit-Ethernet interfaces. Low Speed and High Speed CAN are counted only as CAN. The various interfaces are explained in later chapters.

Attention:

Based on the specification of the hard drive, the data logger should always be fitted vertically or horizontally (upright or upside down).

Please avoid tight bending of the MOST150 fiber optic cables.

[Index](#)

6 Control elements at the front side

The next section describes the usage of the controls and connectors of the blue PiraT2 / 5E.



Figure 6.1: Front side of the blue PiraT2

Attention:

If you have ordered an external antenna, e.g., for GPS, the connector has to be bolt only by hand NOT with any tools.

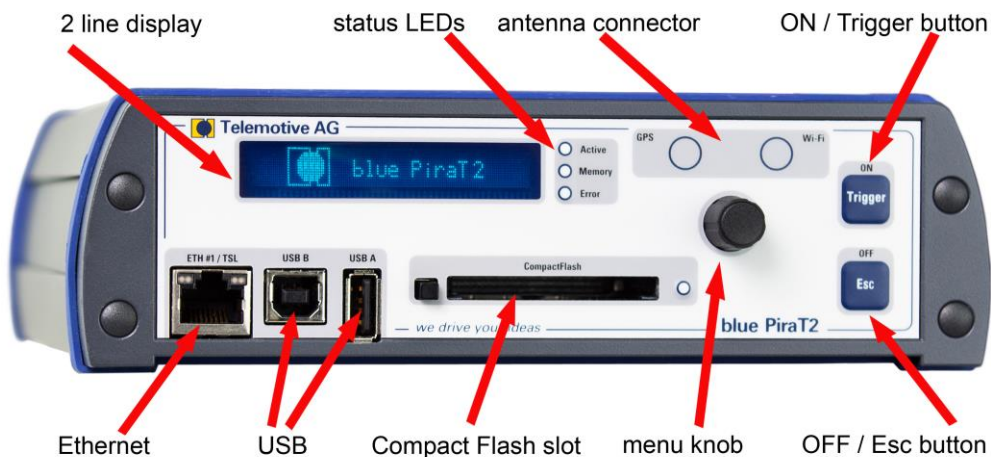

Figure 6.2: Front side of the blue PiraT2 5E

Attention:

At blue PiraT2 ONLY the front Ethernet port is available for controlling the data logger and download data.

On the front side of the blue PiraT2 you will find the display and some control elements.

The blue PiraT2 is available with one 1-Gbit-Ethernet port on the front and also with four additional 100-Mbit-Ethernet ports, where an Ethernet switch is integrated. A mini switch is available with 4 RJ45 connectors.

6.1 ON / Trigger button

The **[ON / Trigger]** button is used to switch on the blue PiraT2 if the data logger is connected to the power and currently in sleep mode.

During operation, interesting points in time can be designated by the **[ON / Trigger]** button. When pressing this button, the data logger saves the current time to hard drive. It is possible to configure the data logger to send a CAN message as an acknowledgement of setting a marker. Additionally, it is possible to define a message that triggers a marker. In all cases, triggers are debounced, allowing only up to ten triggers in between every two seconds.

When downloading the data, the client displays all markers in an event overview. In this event overview, the client can be configured to transfer the data around the selected markers.

6.1.1 Resetting the network settings

Important notice:

Due to a wrong network setting it might be impossible to reach the data logger any more. In this case the network configuration can be resetted by a long press on the [ON / Trigger] button for ca. 5 – 10 sec. to default settings: DHCP server with IP:192.168.0.233.

Afterwards the data logger can be reached again by using a direct connection with a PC/Laptop.

6.2 OFF / Esc button

If the blue PiraT2 is operating and you hold the **[OFF / Esc]** button for longer time, the data logger will go into the standby mode.

If you only push the **[OFF / Esc]** button for short time you leave the current menu state.

6.3 Status LEDs

The blue PiraT2 has four LEDs on his front side: Active, Memory and Error to the right side from the display and CFAActive on the right side from the Compact Flash slot.

LED	Behavior
Active	on as long as the data logger is operating
Memory	active, if the data logger is not in the ring buffer mode blinking, if the storage capability exceeds 75 % continuous on, if the storage capability is used by 100 %
Error	on, if an error which has occurred is still active
CFActive	indicates that the blue PiraT2 has recognized the compact flash card

Table 6.1: LED behavior

6.4 External storage

External memory can be used to download trace data from the data logger, to update firmware and licenses or install a configuration. It can be used to download a bug report too.

The **blue PiraT2** offers additional the possibility to store data parallel to a removable media as SD card or USB device. The configuration of the feature **[Logging to External Storage]** is described in the Telemotive System Client user guide.

6.4.1 Compact Flash card (CF)

The CF card has to be formatted in the FAT32 file format. The card reader supports Compact Flash 4.1 (CF UDMA Modes 0-4, CF PIO Modes 0-6).

We recommend using the “SanDisk Extreme 16 GB CompactFlash” or the “STEC SLCF8GM2PUI CompactFlash”. For these are fully suitable for automotive requirements.

Please note:

- Datalogger with HW 1.x:

Insert the CF card with the label facing down in the CompactFlash Slot.

- Datalogger with HW 2.x:

Insert the CF card with the label facing up in the CompactFlash Slot.

The usage is described in chapter **6.6.7 Memory** .

6.4.2 USB storage

The USB storage has to be formatted in the FAT32 file format. You could connect USB flash drives and external hard drive up to a maximal supply current of 500 mA at blue PiraT2 and 800 mA at blue PiraT2 5E. External power supplies are not needed.

Note:

Telemotive AG recommends the testing of every external storage before using it in a measurement. We suggest that especially USB devices with USB 3.0 are sometimes not recognized by the system.

The usage is described in chapter **6.6.7 Memory** .

6.5 Menu knob

For control the menu of the logger the **[menu]** knob is used. The **[menu]** knob has a rotary/push controller function: rotate the button to the left equates to up and rotate it to the right equates to down. Pushing the button equates the OK function.

6.6 Display

The menu includes the two line display at the front. The **[menu]** knob is used for controlling the menu. Rotate the knob to the left equates to an “up” function. Rotate it to the right equates to a “down” function. Pushing the **[menu]** knob is equates to an “OK” or “Enter” function. By pushing the **[OFF / Esc]** button the current menu item will be left.

But holding the **[OFF / Esc]** button pressed for more than 5 seconds, the logger will switch into the standby mode without any confirmation.

6.6.1 Startup

During the Startup phase the display shows:
blue PiraT2

After the Startup phase is finished, the display shows the status of the most important interfaces. For a MOST25 version the MOST25 and FlexRay will be displayed on the beginning:

M25-
FR NN--

By rotating the **[menu]** knob you can navigate through the entire interfaces. On the following table you can find the abbreviation for the displayed interfaces and the possible status information.

Abbr.	Interface	- = Off	X = Not con-nected	N = No Traffic	T = Traffic	E = Error	S = Switch mode
CAN	CAN	x		x	x	x	
CCP/XCP	CCP/XCP	x	x	x	x	x	
ETH	Ethernet	x	x	x	x		x
FR	FlexRay	x		x	x		
LIN	LIN	x		x	x		
M25	MOST25	x	x	x	x		
M150	MOST150	x	x	x	x		
VID	Video	x	x		x		
SER	Serial	x		x	x		

Table 6.2: Interface abbreviations and status information

6.6.2 Menu mode

By pushing the **[menu]** knob you can enter the menu mode and you can see the following two lines.

--- Menü ---
[1] Info

Currently the menu has five main categories:

1. Info
2. Licenses
3. Functions
4. Error Memory
5. Memory Device

The currently selected category is displayed inverted. By pushing the **[menu]** knob you can go into the selected main category.

[1] Info 1/12
Firmware: 02.02.01

Usually in the first line, the main category number and the name will be displayed on the left side. If one line has not enough space to display the name and the value, the first line will be used for the name and the second for the value.

On the right side the sub category number and the total numbers of sub categories will be displayed (see above).

6.6.3 Info

This main category has currently twelve sub categories:

1. Firmware: current firmware of the logger
2. Hardware: mainboard version of the logger
3. SerialNr: Serial Number of the logger
4. Date/Time: Date and time of the logger
5. Storage: used / protected storage of the hard disc
6. Ext. Mem. Storage: used storage of the external memory / memory size
7. Ext. Mem. Dev: status of the external memory (e.g. CF Recordig)
8. DHCP ...: DHCP status (e.g. DHCP Server)
9. IP: IP address of the logger
10. TERM-IP: Terminal IP address
11. Config: name of the logger configuration
12. WLAN-IP: optional WLAN IP address

By rotating the **[menu]** knob you can navigate through the info list.

6.6.4 Licenses

By entering this main category the logger will list all installed licenses. The message <No Licenses> appears, if no license is installed. By rotating the **[menu]** knob you can navigate through the license list.

6.6.5 Functions

Currently there are two functions available:

Reset IP Config

If the logger has an unknown IP configuration and you have no access to the logger, there is a possibility implemented to reset the IP configuration back to the factory mode (DHCP Server and IP 192.168.0.233).

Rotate the **[menu]** knob till you see "Reset IP Config" and then push the knob to reset the IP configuration. After that, the message <IP Config reset to mode DHCP Server> will be displayed. To assume this setting, a restart is necessary.

Lock Keypad

If this function will be started by pressing the **[menu]** knob, the blue PiraT2 lock its control elements without any confirmation and the message <Keypad locked> appears.

By pressing the **[OFF / Esc]** button for more than 5 seconds the control elements will be unlocked and the message <Keypad unlocked> appears for a short time.

6.6.6 Error Memory

This main category lists all active errors. The message <No errors> appears, if no error is active. By rotating the **[menu]** knob you can navigate through the error messages.

6.6.7 Memory Device

This main category has currently eight sub categories. But these functions can only be executed, if an external memory device is installed. Otherwise the message <Error: No memory device attached > will be displayed.

Currently there is no difference made between memory card (CF) and USB stick.

Note: Never remove the external memory before pressing „Safely remove ext. Mem.“.

6.6.7.1 Copy to memory device

In order to copy the recorded data to an external memory you have to perform the following steps:

1. In the Telemotive System Client under General / External Storage set [Logging on External Storage] to [Off]
2. Click on the button [Write to logger]
3. Restart the logger.

There are five options available in this sub category:

1. Copy all data
2. Copy data of last 60min
3. Copy data of last 12 hours
4. Copy data of last 24 hours
5. Copy data of last 48 hours

By selecting one of the options and pressing the **[menu]** knob the copy function will be executed. The progress of the save operation will be displayed on the display. After the copy process is finished the message < Memory Device success: Data copied > will be displayed for a short time.

The folder name of the offline data has the format "Offline_bp2_ext_FW-*current firmware of the logger*_*serial number of the logger*_*start time of data*_*end time of data*". The times are recorded in the time standard UTC like this: `yyyymmdd_hhmmss`.

6.6.7.2 Erase memory device

After pressing the **[menu]** knob a verification message will be displayed. With the **[OFF / Esc]** button the process can be aborted, with the **[menu]** knob the blue PiraT2 begins to erase the memory of the memory device. After completion the message <Memory card successfully erased> will be displayed.

6.6.7.3 Format memory device

After pressing the **[menu]** knob a verification message will be displayed. With the **[OFF / Esc]** button the process can be aborted, with the **[menu]** knob the blue PiraT2 begins to format the memory device. After completion the message <Memory device successfully formatted> will be displayed.

[Index](#)

6.6.7.4 Install license

On the external memory card has to be a directory **license** where only one license file has to be stored.

If the external memory is inserted, you can navigate to the point "Install license". Press the **[menu]** knob. Now a verification message will be displayed. By pressing the **[OFF / Esc]** button you abort the process or continue by pressing the **[menu]** knob. If you start the function, the message <install license> will be displayed. If the installation was successful, the message <Successful install of license file> will be displayed. Otherwise the message <install failed of license file> is shown.

6.6.7.5 Create bug report

By pressing the **[menu]** knob the logger begins to create the bug report. In the display appears the progress of the creation process. After the creation process is finished the message <Creating Bugreport done> will be displayed for a short time. The bug report will be stored on the external memory device as a zip file in the format „Bugreport_bP2_All_*IP address of the logger*_creation time*“. The time is recorded in the time standard UTC like this: `yyyymmdd_hhmmss`.

6.6.7.6 Firmware update

On the external memory device a folder with the name **update** has to be created, in which the update file has to be stored.

There are two ways to update the firmware of the logger with a removable device.

1) Over the device menu

- a) In the Telemotive System Client under General / External Storage: set **[Firmwareupdate via Removable Media (CF/SD/USB):]** to **[Selection by user via device menu]**
- b) After pressing the **[menu]** knob a verification message will be displayed. With the **[OFF / ESC]** button the process can be aborted. With the **[menu]** knob the blue PiraT2 begins to update his firmware. The message <Updating firmware please wait..> will be displayed for a short time. The update progress appears on the display. If the update is completed <success: Firmware updated> is shown on the display. A restart will be initiated after the update process.

2) Automatically when plugged in or on startup

- a) In the Telemotive System Client under General / External Storage: Set **[Firmwareupdate via Removable Media (CF/SD/USB):]** to **[Automatic detection on startup / plugin]**.
- b) After inserting the removable device or after logger startup with plugged removable device the firmware will be updated automatically and a restart will be initiated.

Attention:

Please note, that after you updated the firmware you should also update the client. Please refer to chapter 7.1 Download and installation of the Telemotive System Client.

6.6.7.7 Install configuration

On the external memory device a folder with the name configuration has to be created, in which only one configuration file has to be stored.

There are two ways to update the firmware of the logger with a removable device.

1) Over the device menu

- a) In the Telemotive System Client under General / External Storage: Set **[Configuration via Removable Media (CF/SD/USB):]** to **[Selection by user via device menu]**

- b) After pressing the **[menu]** knob a verification message will be displayed. With the **[OFF / ESC]** button the process can be aborted. With the **[menu]** knob the blue PiraT2 begins to install the configuration. If the installation was successful, the message <Config updated> will be displayed. Otherwise the message <install failed of Config file> is shown.

2) Automatically when plugged in or on startup

- a) In the Telemotive System Client under General / External Storage: Set **[Configuration via Removable Media (CF/SD/USB):]** to **[Automatic detection on startup / plugin]**.
- b) After inserting the removable device or after logger startup with plugged removable device the configuration will be installed automatically. If the installation was successful, the message <Config updated> will be displayed. Otherwise the message <install failed of Config file> is shown.

6.6.7.8 Safely remove ext. Mem.

If you want to remove the external memory device, you have to select this sub category and press the **[menu]** knob. After that the message <Mem. Device clear to remove now> appears in the display and you can safely remove the external memory device from the data logger.

[Index](#)

7 Starting the blue PiraT2

Connect the blue PiraT2 via the power harness (**red/+/clamp 30** and **black/GND/-/clamp 31**) with the vehicle battery or a power supply.



Figure 7.1: Power connection of the blue PiraT2

Note: blue PiraT2 5E has a separate power cable which is separated from the main cable set!

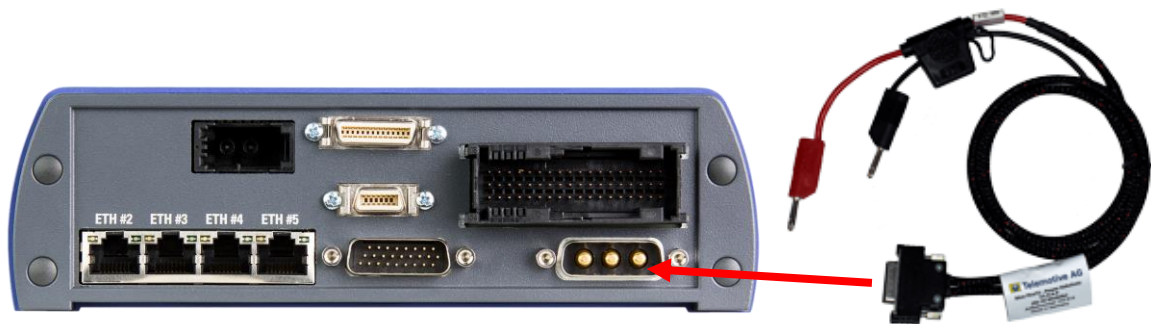

Figure 7.2: Power connection of the blue PiraT2 5E

Attention:

If you have ordered an external antenna, e.g., for GPS, the connector has to be bolt only by hand, NOT with any tools!

Switch the blue PiraT2 on by pressing the **[ON / Trigger]** button and wait until the logger is ready. The logger shows available bus ports.



Figure 7.3: Switching on

For switching off the blue PiraT2 later please press the **[OFF / Esc]** button for a few seconds until the message <----- Shutdown -----> is displayed.

Pressing down the **[menu]** knob will enter the menu mode. Now select the main category “[1] Info”, then choose the sub category “9/12” with the IP in the display. This IP address is required for the next step.



Figure 7.4: Info screen IP address

[Index](#)

7.1 Download and installation of the Telemotive System Client

Open your internet browser, enter the IP address of the logger (Default setting: **192.168.0.233**) and press **[Enter]**.

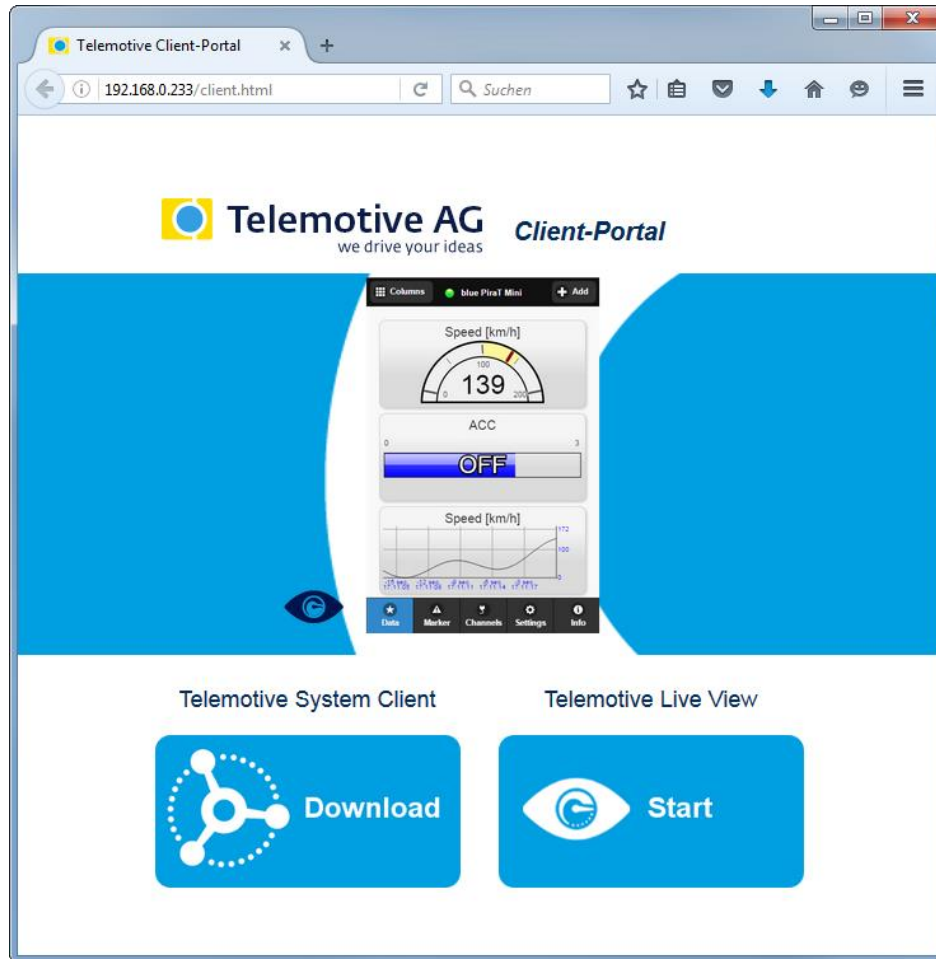

Figure 7.5: Telemotive Client Portal

The connection between the logger and your computer system will be established. Please take care that the network settings of your network adapter are set to **Obtain IP address automatically**.

Click **[Download]**, to download the Telemotive System Client directly from the logger.

Follow these steps, depending on your browser:

Browser	Proceeding
Internet Explorer	Click [Save] , to locally save the file on your system. Click [Accomplish] .
Mozilla Firefox	Click [Save file] , to locally save the file on your system. Click the arrow on the right top of the browser menu and select the downloaded application in the appearing context menu.

In the dialog that opens select the desired software language from the dropdown menu. Click **[OK]**.

Follow the instructions in the next dialog and select an installation directory. Click **[Install]**.

After successful installation you will find the **Telemotive System Client** icon on your desktop. Double-click the icon to start the application.



Figure 7.6: Desktop icon

You can download the entire **manual for the Telemotive System Client** in our ServiceCenter. In the manual, the following operations are described extensively:

- detailed description of the Telemotive System Client
- configuration of the data logger
- download of the recorded data
- conversion of the recorded data
- Firmware-/ License update
- creating a bug report

You can open the manual directly via this link:

https://sc.telemotive.de/4/uploads/media/TelemotiveSystemClient_UserManual.pdf

For having an easy access if necessary, the most important manuals are linked in the client under the menu item **[Help]** and are reachable easily from there.

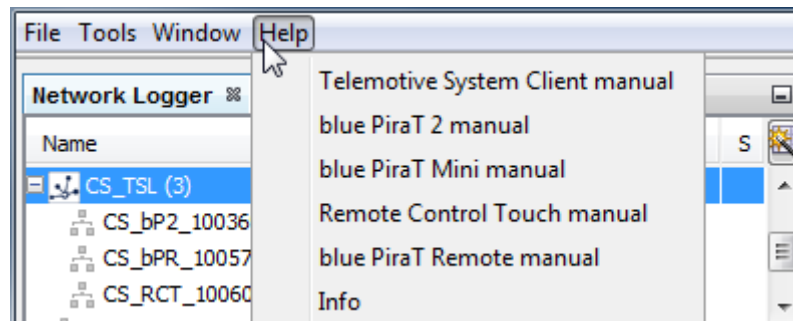

Figure 7.7: links to the manuals

[Index](#)

7.2 Interfaces at the rear side

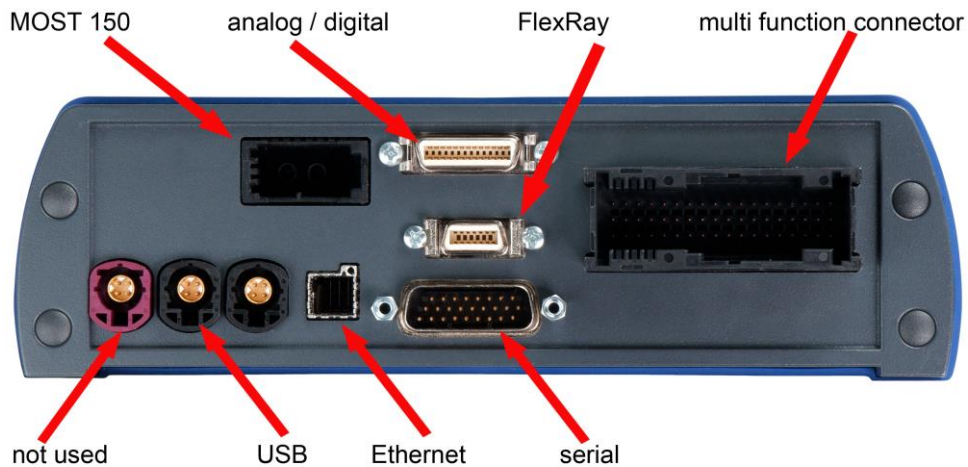

Figure 7.8: Rear side of the blue PiraT2 with MOST150

On the various data logger types are the following connectors possible:

- multi function connector: This connector contains the remaining lines for power, High Speed CAN 1-12, Low Speed CAN 12-13, Remote Control Voice, LIN 1-8. The pin assignment of this connector is described in the chapter 14.1.

Warning:

It is possible that devices connected to the data logger might be damaged in case of an incorrect polarity of the data logger power supply.

- MOST: A standard 2+0 connector for MOST fiber optic.

Important:

If the MOST connector is not used, the jack must be covered with a terminating plug. This prevents the sensitive fiber optic contacts from getting dirty. It also makes sure that the data logger does not start up unintentionally when, e.g., strong sunlight falls onto the optical contacts.

- serial: This connector is described in the chapter 10.3.
- analog/digital: This connector is described in the chapter 14.4.
- FlexRay: One connector for two interfaces with a/b. The pin assignment of this connector is described in the chapter 14.6.
- Ethernet: connector for optional Ethernet-Kit
- USB: not used in the moment

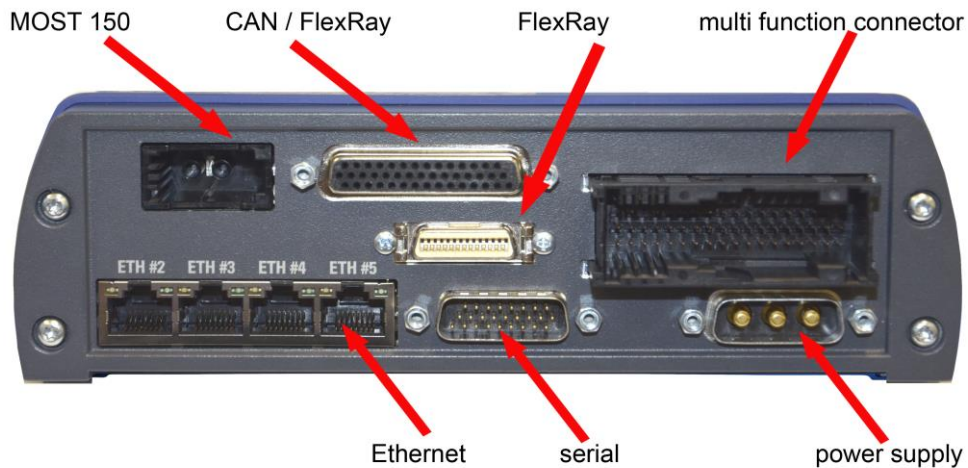

Figure 7.9: Rear side of the data logger blue PiraT2 5E MOST150

Important:

In contrast to the blue PiraT2 the blue PiraT2 5E has a separate power supply (see at the right side below)



Figure 7.10: new power supply connector with reverse polarity protection

The newly delivered loggers are equipped with a reverse polarity protected power supply connector.

The power supply integrated into the MQS plug is used only for supplying an optional connectable RCV / RC.

At blue PiraT2 5E the connection for the external Ethernet switch is replaced by an integrated 4 ports switch at the rear side directly into the device.

The other connectors are the same like at blue PiraT2.

[Index](#)

8 Adapter cables

This section describes which adapter cables are available for the **bluePiraT2** and **blue PiraT2 5E**.

8.1 Universal adapter cable

Telemotive AG offers adapter cables that connect to the multi function connector and split up its lines to separate connectors.

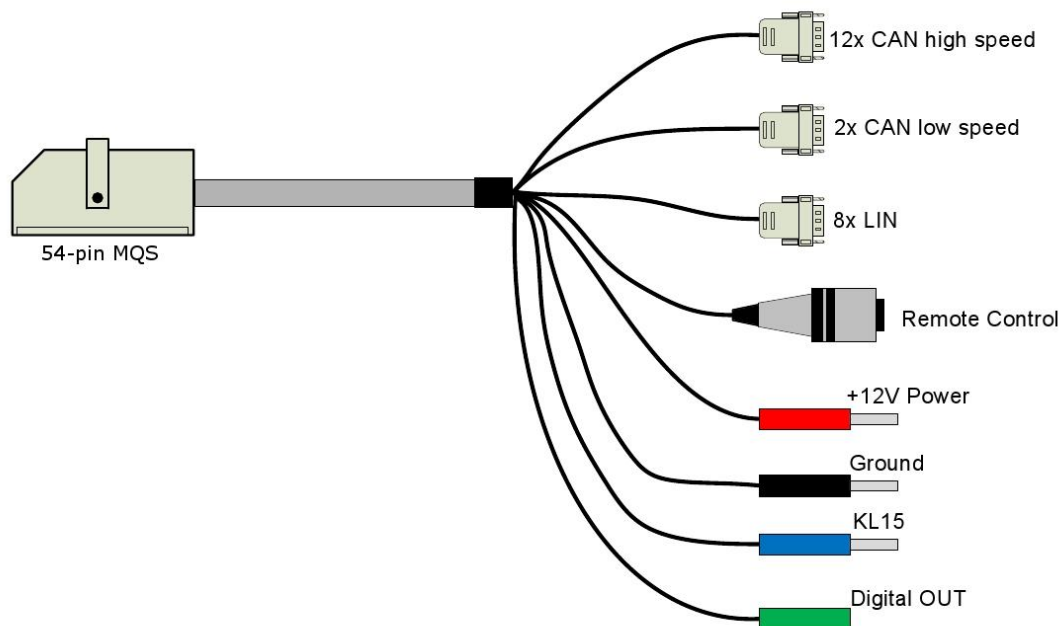
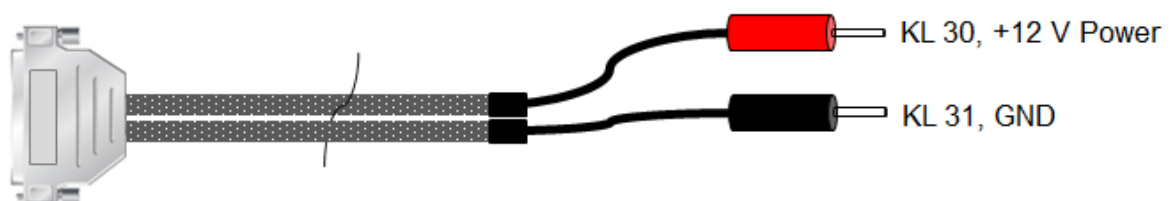

Figure 8.1: Connecting the blue PiraT2 via the universal adapter cable

When the universal cable set is used at a **blue PiraT2 5E** +12V Power and Ground are needed for an optional Remote Control Voice only!

8.2 Power cable for blue PiraT2 5E (Art. 103 614)



SUB-D 3W3C

Length: ~ 105cm

Figure 8.2: Power cable for blue PiraT2 5E

8.3 Adapter cable Serial/RS232, Analog/Digital

The following figure shows the adapter cables for 6x RS232, one digital IN and one analog IN.

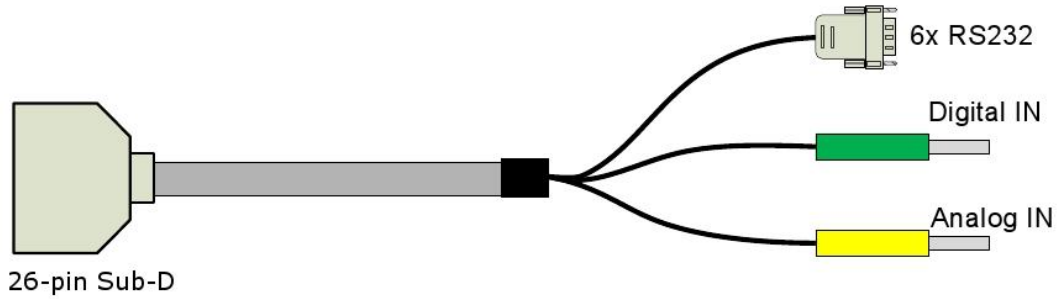

Figure 8.3: RS232/digital/analog adapter cable

Note:

The blue PiraT2 actively sends data on the “Tx” line if a protocol for the serial port is configured. The “Tx” line must only be connected to special devices that support those protocols. If the application is listening to a bidirectional serial communication of two devices, two serial ports of the blue PiraT2 have to be used. The “Tx” lines must not be connected in this case.

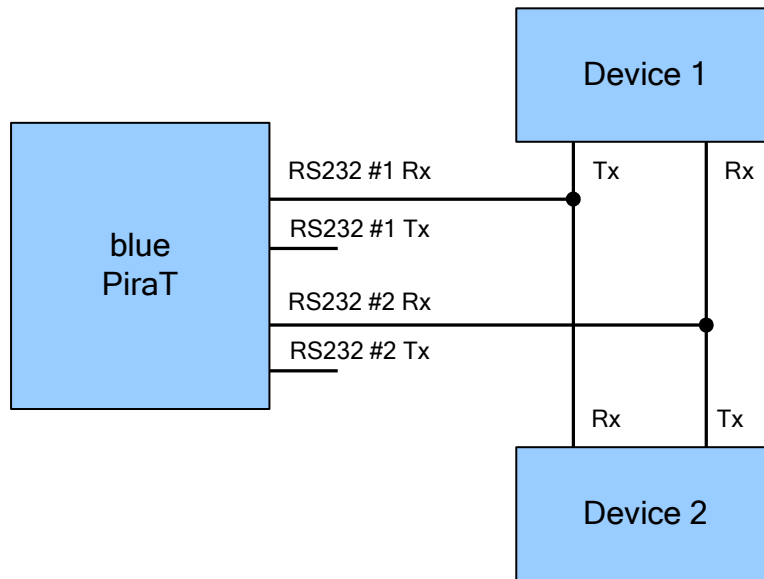

Figure 8.4: Listening to a bidirectional serial communication

8.4 Adapter cables for Analog/Digital

The following figure shows the adapter cables for ECL, 4x digital IN, 8x analog IN and 2x digital OUT.

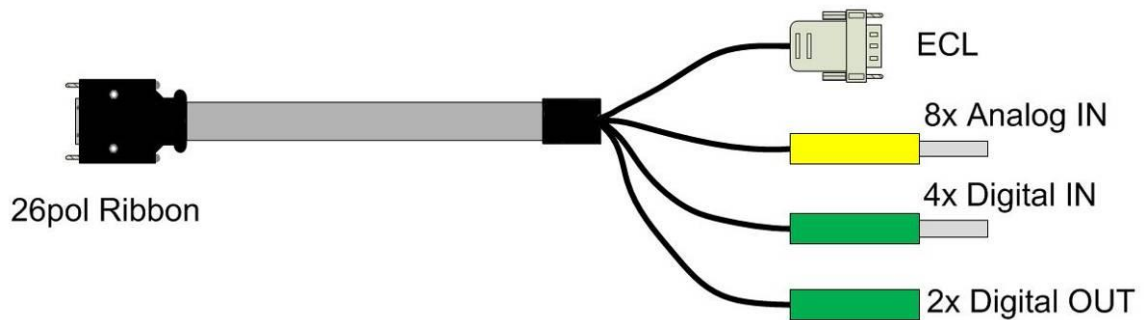

Figure 8.5: Adapter cables for digital/analog

This adapter cable is only available for the logger types 150M14C8LFR and 25M24C8LFR.

8.5 Adapter cable FlexRay

The following figure shows the adapter cables for FlexRay (only for blue PiraT2 150M14C8LFR).

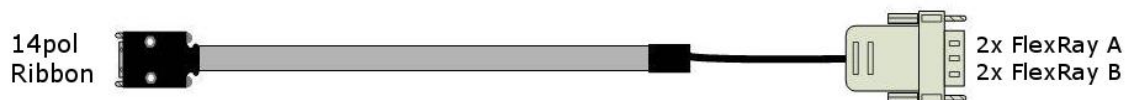

Figure 8.6: Adapter cables for FlexRay

8.6 Adapter cables for CAN/FlexRay

The following figure shows the adapter cables for 10x High Speed CAN and FlexRay (only for blue PiraT2 25M24C8LFR).

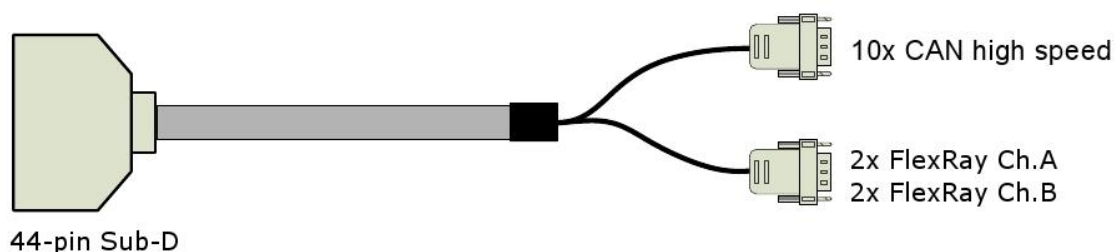
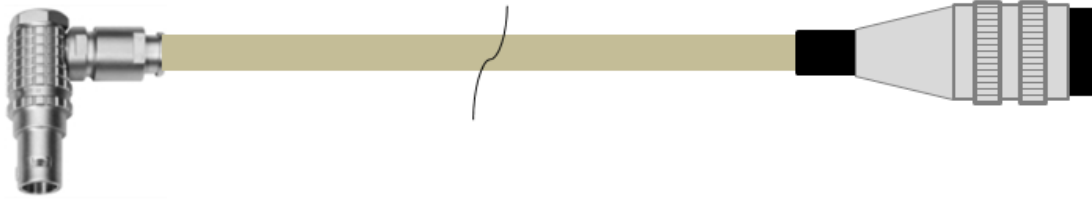

Figure 8.7: Adapter cables for CAN/FlexRay

8.7 Adapter cable for Remote Control Voice (RCV)



Lemo – Stecker / plug
FGH.1B.308.CLAD42

Lumberg – Stecker / plug
SV81-8 DIN8

Length: ~ 500cm

Figure 8.8: Adapter cable for Remote Control Voice (RCV)

Please note:

When using a blue PiraT2 5E the power connector of the universal cable set has to be connected too although this device has an own power cable because this connection is needed for the RCV/RC.

8.8 Ethernet kit for blue PiraT2

The following figure shows the Ethernet box with four interfaces. This would be connected with a FCI-cable to the blue PiraT2.

This kit is available only for blue PiraT2 because blue PiraT2 5E has an integrated 4-port switch.



Figure 8.9: Ethernet kit for blue PiraT2

[Index](#)

9 Logging data

9.1 Setting markers

Interesting points in time can be designated by the **[ON / Trigger]** button at the front panel or at the Remote Control. When pressing this button, the data logger saves the current time to hard drive.

It is possible to configure the data logger to send a CAN message as an acknowledgement of setting a marker.

Besides using the **[ON / Trigger]** button, it is also possible using the digital inputs and **Complex triggers** function to realize an external marker button (have a look at the **Complex Triggers** user guide).

Additionally, it is possible to define a message that triggers a marker. In all cases, marker triggers are debounced.

When downloading the data, the client displays all markers in a data in the data overview. The client can be configured to transfer the data close around selected markers.

9.1.1 Setting marker with an extern push button

Besides using the **[ON / Trigger]** button, it is also possible using the digital inputs and **Complex triggers** function to realize an external Marker button. Important is to set the used interface active and set the „Timing Mode“ under general settings to a <Sampling interval> to at least 100 ms.

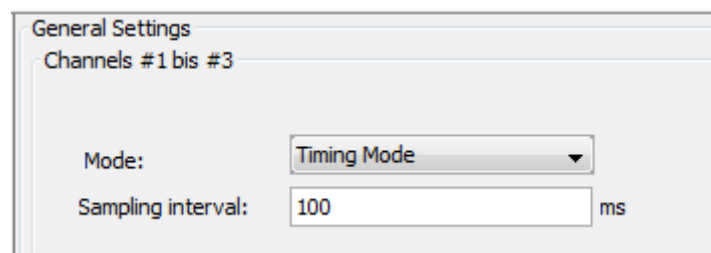

Figure 9.1: Sampling interval

Figure 9.2: Setting triggers using digital Input

The setting for the <Sampling interval> is needed to debounce the external push button and be sure that only one trigger is set. The external push button can be connected to the power supply of the car and the Digital In mentioned above.

9.2 Time stamp

The recorded messages and status messages are provided with a time stamp at the conclusion of the reception, i.e., at the time at which a receiver could receive the message. Usually the recorded messages will get a time stamp at the end of each received message. Only for the serial interface (RS232) the time of the start of the transfer will be used.

Trace Data	Accuracy	Start	End
MOST25	1 µs		x
MOST150	1 µs		x
ECL	1 µs		x
CAN	1 µs		x
LIN	1 µs		x
FlexRay	1 µs		x
Ethernet	100 ms		x
RS232	1 ms	x	

Table 9.1: Accuracy of marker

9.3 Standby mode

The table below shows, which busses or signals are monitored for keeping the logger alive and which busses or signals are able to wake up the logger.

Schnittstelle / Interface	Wachhalten / Keep alive	Aufwecken / Wake up	Konfigurierbar / configurable	Konfigurierbar / configurable	Kommentar / comment
			W = wake up A = keep alive bP2	W = wake up A = keep alive bP2 5E	
MOST25	✓	✓	W / A: Ein / Aus W / A: On / Off	W / A: Ein / Aus W / A: On / Off	Licht an / light on
MOST150	✓	✓	W / A: Ein / Aus W / A: On / Off	W / A: Ein / Aus W / A: On / Off	Licht an / light on
ECL	✓	✓	W / A: Ein / Aus W / A: On / Off	W / A: Ein / Aus W / A: On / Off	
High Speed CAN	✓	✓	W / A: Ein / Aus W / A: On / Off CAN 1-10,11,12,15-24	W / A: Ein / Aus W / A: On / Off CAN 1,2,... - 12,	bP2: gruppiert / combined bP2 5E: einzeln / single
Low Speed CAN	✓	✓	W / A: Ein / Aus W / A: On / Off CAN 13-14	W / A: Ein / Aus W / A: On / Off CAN 13, CAN 14	bP2: gruppiert / combined bP2 5E: einzeln / single
LIN	✓	✓	W / A: Ein / Aus W / A: On / Off LIN 1-2, 3-4, 5-6, 7-8	W / A: Ein / Aus W / A: On / Off LIN 1, 2, 3, 4, 5, 6, 7, 8	bP2: gruppiert / combined bP2 5E: einzeln / single
FlexRay	✓	✓	W / A: Ein / Aus W / A: On / Off W: FlexRay 1a-2b	W / A: Ein / Aus W / A: On / Off W: FlexRay 1a-2b	
Seriell RS232	✓	-	A: Ein / Aus A: On/ Off	W / A: Ein / Aus W / A: On / Off	
Ethernet 1 Gbit	✓	-	A: Ein / Aus, Alive time A: On/ Off, Alive time	A: Ein / Aus, Alive time A: On/ Off, Alive time	Zeit: General/Standby
Ethernet 100 Mbit	✓	-	A: Ein / Aus A: On/ Off	A: Ein / Aus A: On/ Off	
Analog In	-	-	-	-	
Digital In 1	-	✓	W: Ein / Aus W: On/ Off	W: Ein / Aus W: On/ Off	schaltet bei 9,5 V ± 0,3 V ein
Digital In 2	-	✓	W: Ein / Aus W: On/ Off	W: Ein / Aus W: On/ Off	Schwellwert einstellbar Threshold adjustable
Digital In 3-5	-	-	W: On/ Off	-	
USB	-	-	-	-	
Remote Control	-	✓	-	-	via [ON / Trigger] -Taste/ via [ON / Trigger] -button
[ON / Trigger] -Taste/ [ON / Trigger] -button	-	✓	-	-	
WLAN / WiFi	-	-	-	-	

Table 9.2: Standby mode – [W= wake up A= keep alive]

9.4 Memory space and level

About the ring buffer and other options, such as the protection of areas around markers, the characteristics of the logger can be configured what to do, when the internal memory is full.

The following status messages can occur during operation of the data logger. It will also be displayed on the optional Remote Control (RC) / Remote Control Voice (RCV).

9.4.1 Status Logger: OK

Everything is OK

On the internal memory is enough free space to record all incoming data.

blue PiraT2	Memory-LED is off.
blue PiraT2 display	On the info page the display of blue PiraT2 shows the storage level and the amount of protected data. 
RCV	

Table 9.3: Status Logger: OK

9.4.2 Status Logger: WARN

Warning, which does not affect the data recording

9.4.3 Status Logger: RING

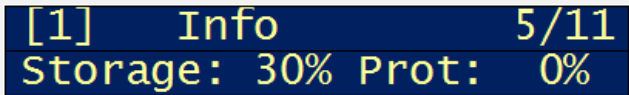
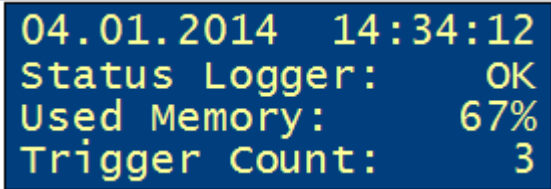
Memory is full, buffer mode is active

The buffer is active and the storage filled more than 95 %. Older data will be deleted to save space for newer data.

blue PiraT2	Memory-LED is off.
blue PiraT2 display	<pre>[1] Info 5/11 Memory: 96% Prot: 30%</pre>
RCV	<p>Line three shows the level of the ring buffer on the internal memory.</p> <pre>04.01.2014 14:35:12 Status Logger: RING Used Memory: 100% Trigger Count: 3</pre>

Table 9.4: Status Logger: RING

9.4.4 Status Logger: MEM

Internal memory is nearly full, no more data will be stored soon

Case 1: The ring buffer is enabled and more than 95 % full (as Status RING), in addition over 90 % of the trace files are protected.

Case 2: The ring buffer is disabled and filled to more than 95 %. When ring buffer mode is disabled all trace files are implicitly protected.

blue PiraT2	Memory-LED is off.
blue PiraT2 display	<pre>[1] Info 5/11 Memory: 100% Prot: 91%</pre>
RCV	<p>Line three now shows the level of the ring buffer with protected files. In the display below we see that the ring buffer is filled to 91 % with protected and to 9 % with non-protected files. Till now the oldest unprotected files will be cleared to make way for new space.</p> <pre>04.01.2014 14:36:12 Status Logger: MEM Prot Memory: 91% Trigger Count: 3</pre>

Table 9.5: Status Logger: MEM

Case 3: The ring buffer is disabled and the memory to 100 % full.

Case 4: The ring buffer is enabled and the memory to 100 % full with protected files.

In both cases, the data recording is stopped because no files can be deleted to make way for new space.

blue PiraT2	Memory-LED switches on.
blue PiraT2 display	The following message is displayed, when recording medium is full (Memory: 100% Prot: 100%). 
RCV	The third line shows flashing that the storage medium is full. For this, the third line is faded in and out every second.  

Table 9.6: Status Logger: Memory Full

9.4.5 Status Logger: ERROR

Error in the logger, the data record is not guaranteed

blue PiraT2	Memory-LED is on.
blue PiraT2 display	
RCV	In the second line of the status "ERROR" flashes every second.  

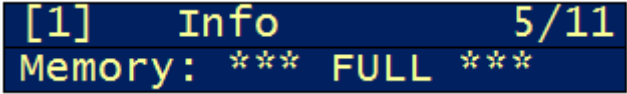
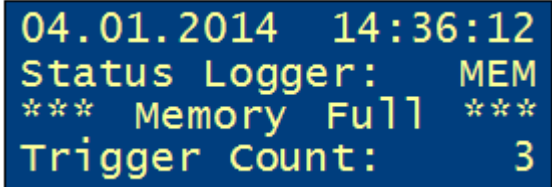
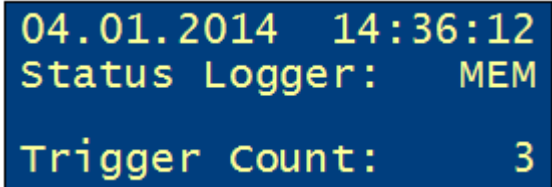
Table 9.7: Status Logger: ERROR

10 Interfaces

The different interfaces of the blue PiraT2 supported bus systems are described in this chapter in more detail.

10.1 CAN

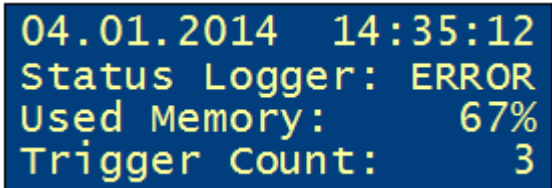
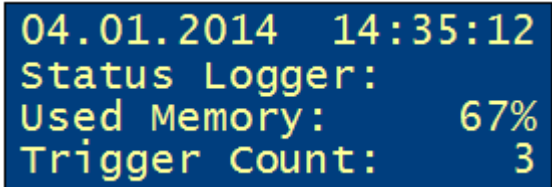
The blue PiraT2 is able to record data in compliance with the CAN specification 2.0a (11 Bit identifier) and 2.0b (29 Bit identifier).

10.1.1 High Speed and Low Speed operating modes

Depending on the model, the blue PiraT2 has different numbers of High Speed (HS) and Low Speed (LS) CAN interfaces. It is not possible to change a CAN interface from Low to High Speed or vice versa. Each type is using different transceivers.

The electrical behavior of the Low Speed and the High Speed CAN is different, hence, the Low Speed CAN port of the blue PiraT2 must not be connected to a High Speed CAN bus and vice versa.

Both operating modes use differential signals (CANH, CANL). For the correct data recording, all nodes of the bus must have a common reference potential. The blue PiraT2 uses the connection “**clamp 31**” as a reference potential. The lines of the High Speed CANs are terminated with a high resistance.

	Low Speed CAN	High Speed CAN
Transceiver chip	Philips TJA1054	Philips TJA1041
Terminating resistor	12k	2k6
Baud rate	50 kbit/s - 125 kbit/s	50 kbit/s - 1 Mbit/s
Supported identifiers (SW)	11 and 29 Bit	11 and 29 Bit
Disabling acknowledge	possible	possible
Time stamps	at the end of the telegram	at the end of the telegram

Table 10.1: CAN

10.1.2 CAN data with 29 Bit identifiers

The blue PiraT2 can also log CAN data with 29 Bit identifiers. You don't have to configure anything. All the CAN data will be logged as they are available on the CAN bus. It is also possible to log CAN messages mixed with 11 Bit and 29 Bit identifiers.

[Index](#)

10.1.3 Recording contents

The blue PiraT2 is able to record the following error states of the CAN bus:

- Stuff error
- Format error
- Acknowledge error
- Bit 0/1 error
- CRC error
- Overrun

These error states are only included in the Telemotive file formats. After reaching a certain number of errors (50 errors), the recording of error states is interrupted until reception of the next successful CAN message to avoid an overload of the recorded data.

10.1.4 Sending CAN messages

If the blue PiraT2 sends a CAN message, it is shown twice in the trace: The first message indicates the transmit request of the data logger and the second message indicates the actual transmission of the message.

In the CANoe file format these messages are indicated as “TxRq” and “Tx”, respectively. The transmit request messages are not included in file format that don't support them.

[Index](#)

10.2 LIN

The blue PiraT2 is able to record data compliant to the LIN specification V1.3, V2.0 and V2.1. The data logger does not actively appear as a bus member. Sending LIN messages is currently not supported.

Channels	Up to 4
Transmission rate	1200, 2400, 4800, 9600, 19200, 20000 Baud
Transmitter	TJA1020
State	Parity BITS, format Check for Header, Checksum for Header and Payload
Terminating resistor	30 kOhm

Table 10.2: LIN

10.2.1 LIN data blocks and time stamps

Each LIN message receives a time stamp, which marks the end of the message. If the data logger receives LIN data without a valid header, it creates blocks containing the erroneous data. The maximum block size is 10 bytes. A block is also concluded after a timeout, which is three times the transmission time of a LIN character.

10.2.2 LIN transceiver

The blue PiraT2 uses the LIN transceiver TJA1020 by NXP (former Philips Semiconductor). Supported baud rates are in the range from 1200 to 20000 Baud. Automatic baud rate detection is currently not supported. The LIN interface is configured as a slave device with a terminating resistor of 30 kΩ.

10.2.3 Special frames and states

Additionally to the normal frame data, the following information is recorded:

- Wake-Up Frames
- Checksum Errors

[Index](#)

10.3 Serial (RS232)

Channels	6x RS232
Data bits	5, 6, 7, 8
Stop bits	1, 2, 1.5
Parity	None, odd, even

Table 10.3: Serial interface

The blue PiraT2 supports only the RS232 specification.

10.3.1 Segmentation of the serial data

The received serial data are clustered into data blocks separately for each channel. Each block is finalized after a certain time or when it reaches a certain maximum size. The time is 30 to 60 ms depending on the channel. The maximum size is 49 to 80 bytes. A time stamp is assigned to each block when it is finalized.

10.3.2 RS232 transceiver

The threshold voltages for data reception are the usual RS232-defined values. A logical "1" is recognized for input voltages smaller 0 Volts, a logical "0" for input voltages higher than 3 Volts.

10.4 FlexRay

The blue PiraT2 is able to record FlexRay bus data according to the FlexRay specification 2.1A. The data logger records all valid and invalid, static and dynamic frames of the two FlexRay channels, including "a" and "b", independently if the FlexRay bus is in a synchronous or asynchronous state.

Channels	2x (a + b)
Max. bit rate	10 Mbit/s
Frames	Static, Dynamic, Null Sync, Startup
Transceiver	AS8221

Table 10.4: FlexRay

[Index](#)

10.5 Ethernet

All versions of the blue PiraT2 data logger are able to log Ethernet data. All data loggers have a 1-Gbit-Ethernet port with RJ45 connector on the front. On the rear side there is a FCI connector which provides four 100 Mbit Ethernet interfaces. An Ethernet kit is available for breaking off this four Ethernet ports to RJ45 plugs.

The **blue PiraT2 5E** has 4 integrated 1-Gbit-Ethernet ports at the rear side.

For connecting the the data logger with a PC only the 1-Gbit port at the front can be used.

From here you'll find a list of the supported protocols. When a protocol requires a license, this will be marked.

10.5.1 GNLogger

For connecting a standard TCP (open socket connection) is used. Therefore the blue PiraT2 is a TCP slave device.

GNLogger is a proprietary serial protocol used for some ECU diagnosis.

10.5.2 UTF8

The blue PiraT2 will initiate a TCP connection to a TCP server by using an open socket connection (you can configure IP/Port of server via client software).

By using UTF8 data transmission the logger will write a timestamp after every detected Linefeed (LF) from the incoming data.

If the connection is getting lost, it will take about 5 seconds to build up a new connection for logging data again.

10.5.3 Raw

When using the raw data transmission over TCP the blue PiraT2 will be a TCP slave device. Therefore the blue PiraT2 will initiate a TCP connection to a TCP server by using an open socket connection (you can configure IP/Port of server via client software).

When using raw data transmission, every data package up to 40 Kbytes is getting a time stamp and will be written on the logger.

If the connection is getting lost, it will take about 5 seconds to build up a new connection for logging data again.

10.5.4 UDPServer

The blue PiraT2 can be configured as a UDP server by setting up an IP address and port number.

There is an adjustable timeout. The connection will be terminated if no data arrives. This appears as a message in the trace file. There is no configurable debug level. The blue PiraT2 as a UDP server accepts UDP data packets, UDP multicast and UDP broadcast packets.

If the connection is getting lost, it will take about 5 seconds to build up a new connection for logging data again.

10.5.5 TCPServer

The blue PiraT2 can be configured as a TCP server by setting up an IP address and port number.

There is an adjustable timeout. The connection will be terminated if no data arrives. This appears as a message in the trace file. There is no configurable debug level. The blue PiraT2 as a TCP server accepts TCP data packets, TCP multicast and TCP broadcast packets.

If the connection is getting lost, it will take about 5 seconds to build up a new connection for logging data again.

10.5.6 SpyMode

By using the Ethernet Spy mode it is possible to log all Ethernet data (promiscuous mode).

More information can be found in the **Telemotive System Client User Guide**.

10.5.7 EsoTrace

By using the EsoTrace mode it is possible to log data in the EsoTrace protocol.

More information can be found in the **Telemotive System Client User Guide**.

10.5.8 Camera (license required)

If you use a camera license on the data logger, it is possible to connect up to four Ethernet webcams to the blue PiraT2. After connecting the blue PiraT2 is able to log MPEG4 video streams.

More information can be found in the **Camera User Guide**.

10.5.9 DLT (license required)

If you use a DLT license on the data logger, it is possible to connect up to 16 ECU for logging their DLT messages.

More information can be found in the **DLT-logging User Guide**.

[Index](#)

10.6 MOST25

The **blue PiraT2 MOST25** data logger is able to log messages from the MOST25 bus of the following types.

Status	MPR (Maximum Position Register), SBC, Light on, MOST Lock Flag
Control	Control Messages
Packet	MDP (MOST Data Packet)
Filter	Control Messages on/off, Packet on/off, MDP on/off, Status on/off, MDP Transmit and Receive Address, Packet Length

Table 10.5: MOST25 data logging

The SMSC SpyNIC MOST25 is used to provide the MOST25 traffic data. The data logger is not an active part of the bus system because it is working in a spy mode. The device is able to log messages immediately after wake up.

Before the logging data are saved on the hard disk, they are buffered in a ring buffer. In the case of a data rate peak, which exceeds the storage rate of the hard disk, storage of data is still possible.

If the MOST25 data rate is permanent higher than the maximum storage rate, the data logger will stepwise deactivate channels: first the MDP channel, then the control channel and at last the status messages.

To ensure logging of maximum continuous data blocks a hysteresis is implemented. Before logging MDP messages again, the ring buffer data has to be fully stored on the hard disk. Before starting the logging of the MDP messages again the system sends a "Lost Message". This message contains information about how many messages of which type were rejected.

10.7 MOST150

The **blue PiraT2 MOST150** data logger is able to log messages from the MOST150 bus of the following types.

Status	MPR (Maximum Position Register), MDC (MOST Data Channel), Light On, System Lock Flag, Shut Down Flag, Ring Lock Flag, Open Ring/Multi Master Flag, Node Position Changes of the states are only logged when the state is changing.
Control	Control Messages
Packet	MDP (MOST Data Packet), MEP (MOST Ethernet Packet)
Filter	Control Messages on/off, Packet on/off, MDP on/off, MEP on/off, Status on/off, MDP Transmit and Receive Address, Packet Length, MEP Receive Address, Message Length

Table 10.6: MOST150 data logging

The SMSC SpyNIC MOST150 is used to provide the MOST150 traffic data.

The data logger is not an active part of the bus system because it is working in a spy mode. The device is able to log messages immediately after wake up.

Before the logging data are saved on the internal memory, they are buffered in a ring buffer. In the case of a data rate peak, which exceeds the storage rate of the internal memory, storage of data is still possible.

If the MOST150 data rate is permanent higher than the maximum storage rate, the data logger will stepwise deactivate channels: first the MEP and MDP channel, then the control channel and at last the status messages.

To ensure logging of maximum continuous data blocks a hysteresis is implemented. Before logging MEP and MDP messages again, the ring buffer data has to be fully stored on the hard disk. Before starting the logging of the MEP and MDP messages again the system sends a "Lost Message". This message contains information about how many messages of which type were rejected.

10.8 ECL

Currently the ECL (Electrical Control Line) is only supported in conjunction with MOST150. In general, the ECL is a slow LIN bus. The following ECL messages will be recorded:

- EWU (Electrical Wake-Up)
- STWU (System Test Wake-Up)
- STP (System Test Parameters)
- STR (System Test Results)
- Undefined Pulse

[Index](#)

11 Conversion of recorded traces

All trace data will be recorded internally in the proprietary Telemotive TMT format (*.tmt). If the recorded trace data will be downloaded and sorted, the data will be converted to an Extended TMT format (*.xtmt).

The client provides the possibility to convert the internal format in other formats, to make the data readable or to prepare them for available analyzing tools.

More information about the file formats and a detailed manual for conversion can be found at the **Telemotive System Client User Guide**.

11.1 Conversion format overview

The table below shows which data of the interfaces can be converted to other formats.

Tracedaten / Trace data	Format / format																										
	*.txt APN ASCII	*.txt ASCII Hexadecimal	*.dit Autosar DLT	*.bif Binary Logging	*.CANORDER.asc CANORDER	*.asc CANoe ASCII	*.esotrace Eso Trace file	*.raw Ethernet Raw	*.xtmt Extended Telemotive	*.xjao GN-Log	*.gpx GPS Exchange	*.kml KML Google Maps	*.kntz KMZ comp. Google Maps	*.log MDF Logging	*.mdf MDF Signal v3.3	*.mf4 MDF Signal v4.1	*.img MOST Data Analyser	*.mpeg4 MPEG-4	*.ts MPEG Isochron raw file	*.nmea NMEA - ASCII GPS	*.op2 Oplotyzer	*.RAW.txt RAW Serial	*.txt Serial Debug	*.txt Serial Trace Analyser	*.pcap TCPdump	*.txt Telemotive ASCII	*.trc Trace Client
Analog IN					X	X		X																			X
CAN				X	X	X		X						X	X	X											X
CCP_XCP								X							X	X											X
Digital IN								X																			X
ECL								X										X									X
Ethernet		X	X				X	X	X	X															X	X	
- Ethernet - DLT			X					X	X																		X
- Ethernet - EsoTrace							X	X	X																		X
- Ethernet - GN Log								X	X	X																	X
- Ethernet - RAW								X	X																		X
- Ethernet - Spy Mode/MII				X				X	X																X	X	
- Ethernet - TCP Server								X	X																		X
- Ethernet - UDP Server								X	X																		X
- Ethernet - UTF8								X	X																		X
FlexRay				X	X			X																			X
GPS								X		X	X	X								X							X
Kamera/Video																			X								
LIN				X	X			X																			X
MOST150 CTRL				X				X										X									X
MOST150 MDP				X				X										X									X
MOST150 MEP				X				X										X							X	X	
MOST150 Streaming				X				X										X		X							
MOST25 CTRL				X	X			X										X				X					X
MOST25 MDP				X	X			X										X									X
Serial RS232	X	X	X				X	X	X														X	X	X		X
Signal based filter (Format wird beibehalten / keeps the used format)								X																			X
USB / Conn.-Gateway MLBevo																							X	X			X
Marker																											
Konvertierung / converting	1	1	m	m	m	m	1	1	m	1	1	1	1	m	m	1	m	1	m	1	m	1	m	1	m	1	
Marker	M	Marker kann in Trace geschrieben werden																									
	P	Marker kann nur als CAN / MOST Pseudonachrichten in die Datei geschrieben werden																									
Konvertierung / converting	m	eine Datei für mehrere Kanäle																									
	1	einzelne Datei pro Kanal																									

Table 11.1: Conversion options (overview)

12 Service and safety instructions

Note according to standard EN55011:2009

The data logger is used in an industrial environment. Due to the behavior of conducted as well as radiated disturbances it possibly can be difficult to ensure electromagnetic compatibility in other environments.

Cleaning

The data logger should only be cleaned with a clean, slightly dampened cleaning cloth with water. Other cleaning supplies such as petrol, alcohol etc. may not be used.

Maintenance

The data logger is maintenance-free. The customer is not allowed to open the housing. Unauthorized modifications will void the warranty.

Fuse

In case of an error the customer may change only the fuse on the harness or externally accessible fuses. The fuse may be replaced only with a fuse of the same type and current rating.

Disposal

The disposal of the device must be in accordance to statutory provisions.

12.1 Safety advice

Installation instructions

The data logger should only be installed in the six axes.

Operating temperature

The device must not be operated outside of the specified temperature range. It is important to ensure adequate ventilation. The data logger must not be placed too close to walls or other equipment. The data logger must not be stacked together with other components on each other, unless proper ventilation is ensured and the device should be used in ambient temperatures of more than 77 °F.

Storage conditions

The data logger must be stored only in the range of - 22 °F to + 158 °F.

Condensation

The device must not be switched on directly, if it is brought from a cold environment into a room with normal ambient conditions.

Environmental conditions

The device must not be used outdoors or in adverse environmental conditions such as moisture, high humidity or dust. Furthermore, an operation of the device is not allowed in fire hazardous or explosive gases.

Cable sets

When inserting the cable sets only a small effort may be applied. When you feel an increased resistance while inserting the cable set, the correct alignment of the pins should be checked.

It may only be used the original Telemotive components. Other components such as special cable sets have to be prepared strictly according to the pin assignment in the user guide. You should always spare an extra fuse in the wiring harness.

Three pins with the names clamp 30 and clamp 31 are interconnected for the voltage supply of the data logger. **Caution: A short circuit between the clamp 30 and clamp 31 on the plug may lead to the destruction of the data logger.**

The maximum value of the power supply must not exceed 32 V. In case of overvoltage the device can be destroyed and will void the warranty.

Mounting

The data logger has to be fixed in laboratory setups and especially in automobiles, so that it is secured against falling, slipping and skidding around.

Positioning of the antenna

During operation of the data logger in an automobile the antennas which are connected to the data logger must not be located outside the vehicle.

Mechanical action

+++++ Operation environment +++++

Height: - 300 to 5500 m

Shock at 2 ms half sinusoidal wave 300 G

Vibration sinusoidal wave 3 G (10 – 50 Hz)

2.5 G (50 – 2000 Hz)

2 G (200 – 5000 Hz)

+++++ Out of operation environment +++++

Height: - 300 to 12000 m

Shock at 1 ms half sinusoidal wave 800 G

Vibration sinusoidal wave up to 5 G (10 - 500 Hz)

[Index](#)

13 Data sheet

General data	blue PiraT2	blue PiraT2 5E
Nominal power supply voltage	13.8 V	13.8 V
Power supply voltage	6.5 to 32 V (at system start up logger needs > 8.5 V)	5 to 32 V (at system start up logger needs > 8.5 V)
Reverse polarity protection of the supply voltage	Yes	Yes
Resistance to short-circuiting	Yes	Yes
Power consumption / operating (typ.)	1.8 A (@ 13.8 V)	1.8 A (@ 13.8 V)
Power consumption / operating (peak.)	10 A (start up current, max. 5 ms)	10 A (start up current, max. 5 ms)
Power consumption / standby	< 10 mA up to HW 1.4 < 3 mA from HW 1.5	< 4 mA
Operating temperature	- 22 °F to + 140 °F	with HD: - 22 °F to 140 °F with SSD: - 40 °F to 140 °F
Storage temperature	- 22 °F to + 158 °F	- 22 °F to 158 °F
Weight (ca.)	2.4 Kg	2,8 Kg
Power backup	No	Yes, > 30 ms (starter curve)

Power Management	blue PiraT2	blue PiraT2 5E
Startup time from standby to full operation	< 30 s	with HD: typ. 29s with SSD: typ. 19s
Start of logging	CAN, LIN, Serial, Analog (#1, #2), Digital (#1) < 25 ms	CAN, LIN, Serial, Analog (#1, #2), Digital (#1) < 25 ms
	FlexRay, MOST, Digital (#2 to #5) < 45 ms	like blue PiraT2
	Analog (#3 to #10) < 53 ms Ethernet < 18 s	like blue PiraT2
Standby Mode	Configurable time without bus load	like blue PiraT2
Wake	MOST, HS-CAN, LS-CAN, LIN, FlexRay, Digital (#1, #2), KL 15, [ON / Trigger] button	like blue PiraT2 + Serial, where every port is configurable
Data loss by power loss	If the device is switched off due to sudden power loss, up to 60 sec. of data may be lost.	If the device is switched off due to sudden power loss, up to 60 sec. of data may be lost.

Case	blue PiraT2	blue PiraT2 5E
Size (ca.)	10,83" x 7,48" x 2,36" (275 mm x 190 mm x 60 mm)	like blue PiraT2
Operating controls	Push-button to start data logger and set markers Push-button to shut down Menu button	like blue PiraT2
Display	two line display Active-LED (green): Displays data logger activity Memory-LED (yellow): Displays memory warnings Error-LED (red): Displays internal errors CFActive (green): Displays the detecting of memory card	like blue PiraT2

Connectors	blue PiraT2	blue PiraT2 5E
Connectors (front)	Gbit Ethernet, Wi-Fi 802.11 b/g/n (optional), GPS (optional), CF-Flash, USB 2.0 type A	like blue PiraT2 + USB 2.0 type B
BP2 150M14C8LFR (back)	Power supply, 12x HS-CAN, 2x LS-CAN, 8x LIN, 4x ETH, 6x Serial, 10x Analog In, 5x Digital In, 3x Digital Out, 2x (a/b) FlexRay, MOST150, Rosenberger (2x USB 2.0 type A, 1x USB 2.0 type B)	like blue PiraT2 without Rosenberger (USB) + 4x RJ45 (Ethernet), power supply in separate cable
BP2 25M24C8LFR (back)	Power supply, 22x HS-CAN, 2x LS-CAN, 8x LIN, 4x ETH, 6x Serial, 10x Analog In, 5x Digital In, 3x Digital Out, 2x (a/b) FlexRay, MOST25, Rosenberger (2x USB 2.0 type A, 1x USB 2.0 type B)	like blue PiraT2 without Rosenberger (USB) + 4x RJ45 (Ethernet), power supply in separate cable
BP2 14C6S8L (back)	Power supply, 12x HS-CAN, 2x LS-CAN, 8x LIN, 4x ETH, 6x Serial, 2x Analog In, 1x Digital In, 1x Digital Out, Rosenberger (2x USB 2.0 type A, 1x USB 2.0 type B)	like blue PiraT2 without Rosenberger (USB) + 4x RJ45 (Ethernet), power supply in separate cable

Data recording	blue PiraT2	blue PiraT2 5E
Storage type (external)	CF card USB flash drive	like blue PiraT2 like blue PiraT2
Storage type (internal)	Hard drive 2.5" 100 GB (new: 320 GB) SSD 128/265/480 GB	like blue PiraT2 like blue PiraT2
Recording modes	Normal, ring buffer	like blue PiraT2
Timestamp accuracy	1 µs (MOST, CAN, LIN, FlexRay) 1 ms (Serial) 100 ms (Ethernet)	like blue PiraT2

MOST150 recording BP2 150M14C8LFR	blue PiraT2	blue PiraT2 5E
Channel	MDP MOST data packets, MEP MOST Ethernet packets, control channel, network status, MOST streaming (synchronous/isochronous) (optional)	like blue PiraT2
Status recording	Light on/off, Lock on/off	like blue PiraT2
Filter	MDP filter (source address, target address), MEP filter (target MAC address)	like blue PiraT2

MOST25 recording BP2 25M24C8LFR	blue PiraT2	blue PiraT2 5E
Channel	MDP MOST data packets, control channel, Network Status,	like blue PiraT2
Status recording	Light on/off, Lock on/off	like blue PiraT2
Filter	MDP filter (source address, target address)	like blue PiraT2

CAN recording All types	blue PiraT2	blue PiraT2 5E
Channel	BP2 150M14C8LFR: 12 High Speed, 2 Low Speed BP2 25M24C8LFR: 22 High Speed, 2 Low Speed	like blue PiraT2
Baud rate	Up to 1000000 Baud at HS-CAN up to 125000 Baud at LS-CAN	like blue PiraT2
Transceiver	TJA1041A, TJA1054A	TJA1041A, TJA1055T
Filter	CAN ID filter	like blue PiraT2
Status recording	Error frames	like blue PiraT2
First frame mode	No	Yes

Serial recording All types	blue PiraT2	blue PiraT2 5E
Type	RS232	like blue PiraT2
Channel	6	like blue PiraT2
Baud rate	1200, 2400, 4800, 9600, 19200, 38400, 57600, 115200, 230400, 460800, 921600 Baud	like blue PiraT2
Data bits	5,6,7,8	like blue PiraT2
Stop bits	1,1.5,2	like blue PiraT2
Parity	None, odd, even	like blue PiraT2

LIN recording All types	blue PiraT2	blue PiraT2 5E
Channel	8	like blue PiraT2
Baud rate	1200, 2400, 4800, 9600, 10400, 19200, 20000 Baud	like blue PiraT2
Transceiver	TJA1021	like blue PiraT2

FlexRay recording not in BP2 14C6S8L	blue PiraT2	blue PiraT2 5E
Channel	2x (a/b)	like blue PiraT2
Bit rate	Up to 10 Mbit/s	like blue PiraT2
Transceiver	AS8221B	like blue PiraT2
Recording	Null frames, Startup Phase, Trailer CRC, Symbol	like blue PiraT2

Ethernet recording	blue PiraT2	blue PiraT2 5E
Port	5	like blue PiraT2
Speed	1x 1 Gbit/s (front side) 4x 100 Mbit/s (rear side)	like blue PiraT2, Ethernet port at the rear side has 1000 Mbit/s too
Recording	GNLog, Raw, UTF8, UDP, DLT (optional), EsoTrace (optional)	like blue PiraT2

Analog recording (#1 and #2) All types	blue PiraT2	blue PiraT2 5E
Channel	1x Ubat (internal), 1x external	like blue PiraT2
Range of measurement	0 V to + 20 V	like blue PiraT2
Resolution	7 mV	like blue PiraT2
Accuracy	3 %	like blue PiraT2
Sampling interval	1 ms to 100 s	like blue PiraT2

Digital input (#1) All types	blue PiraT2	blue PiraT2 5E
Channel	1	like blue PiraT2
Switching threshold	9.5 V ± 0.2 V	like blue PiraT2
Hysteresis	0.3 V ± 0.2 V	like blue PiraT2
Sampling interval	1 ms to 100 s	like blue PiraT2

Digital output (#1) All types	blue PiraT2	blue PiraT2 5E
Channel	1	like blue PiraT2
Output voltage	~ Ubat	like blue PiraT2
Output current	Up to 1 A (continuous load)	like blue PiraT2

Analog recording (#3 to #10) not in BP2 14C6S8L	blue PiraT2	blue PiraT2 5E
Channel	8	like blue PiraT2
Range of measurement	- 10 V to + 20 V	like blue PiraT2
Resolution	8 mV	like blue PiraT2
Accuracy	3 %	like blue PiraT2
Sampling interval	1 ms to 100 s	like blue PiraT2

Digital input (#2 to #5) not in BP2 14C6S8L	blue PiraT2	blue PiraT2 5E
Channel	4	like blue PiraT2
Switching threshold	Configurable from 0 V to 12 V	like blue PiraT2
Hysteresis	3 V ± 1 V	like blue PiraT2
Sampling interval	1 ms to 100 s	like blue PiraT2

Digital output (#2 to #3) not in BP2 14C6S8L	blue PiraT2	blue PiraT2 5E
Channel	2	like blue PiraT2
Output voltage	~ Ubat	like blue PiraT2
Output current	Up to 0.5 A (continuous load) BP2 150M14C8LFR	like blue PiraT2
	Up to 1.0 A (continuous load) BP2 25M24C8LFR	like blue PiraT2

Table 13.1: Datasheet

14 Pin assignments and harnesses

Cable	Interfaces	blue PiraT2			blue Pirat2 5E		
		150M14C8LFR	25M24C8LFR	14C6S8L	150M5E14C	25M5E24C	14C5E6S
blue PiraT2 / blue PiraT2 5E universal harness see chapter: 14.1 Data logger: Multi function connector	Power, GND, Wake						
	12x High Speed CAN						
	2x Low Speed CAN	✓	✓	✓	✓	✓	✓
	8x LIN						
	1x Digital Out						
	Remote Control I/F						
blue PiraT2 5E power supply see chapter: 14.2 blue PiraT2 5E – power harness	Power, GND	-	-	-	✓	✓	✓
blue PiraT2 / blue PiraT2 5E Serial/UART extension harness see section: 14.3 Serial connector (D-Sub 26)	6x RS232						
	1x Analog In	✓	✓	✓	✓	✓	✓
	1x Digital In						
blue PiraT2 / blue PiraT2 5E Analog/Digital extension harness see chapter: 14.4 Analog/Digital connector (26-pin) (not at 14C6S8L)	8x Analog In						
	4x Digital In	✓	✓	-	✓	✓	-
	2x Digital Out						
	1x ECL						
blue PiraT2 / blue PiraT2 5E FlexRay extension harness see chapter: 14.6 FlexRay connector	2x FlexRay a	✓	-	-	✓	-	-
	2x FlexRay b						
blue PiraT2 / blue PiraT2 5E CAN/FlexRay extension harness see chapter: 14.7 CAN/FlexRay (D-Sub 44) (25M24C8LFR only)	10x High Speed CAN						
	2x FlexRay a	-	✓	-	-	✓	-
	2x FlexRay b						
blue PiraT2 Ethernet extension kit see chapter: 14.8 Pinning of the FCI connector for the Ethernet-Kit	4x Ethernet RJ45	✓	✓	✓	-	-	-

Table 14.1: Extension harness (overview)

[Index](#)

Warning:

Clamp 31 should be the only ground connection between the data logger and connected devices. Connecting signal ground lines is limited to special cases in which one can guarantee that ground loops cannot occur.

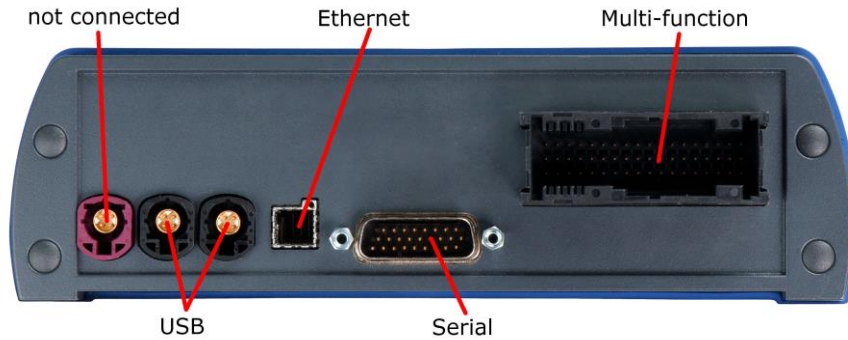

Figure 14.1: Rear side blue PiraT2_14C6S8L

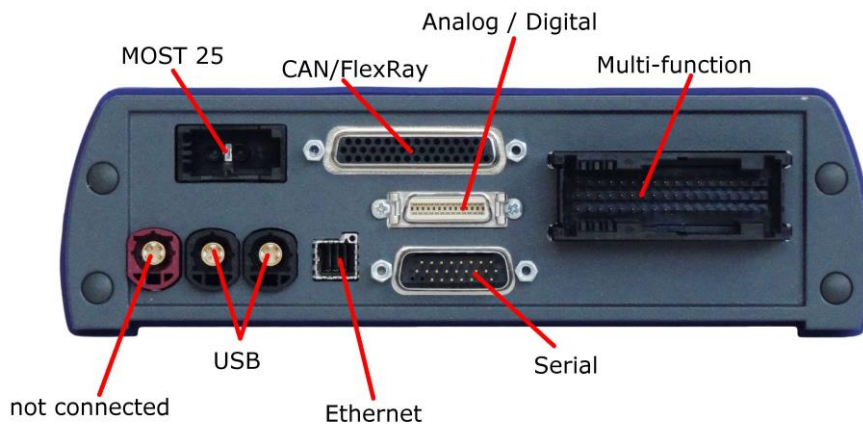

Figure 14.2: Rear side blue PiraT2_25M24C8LFR

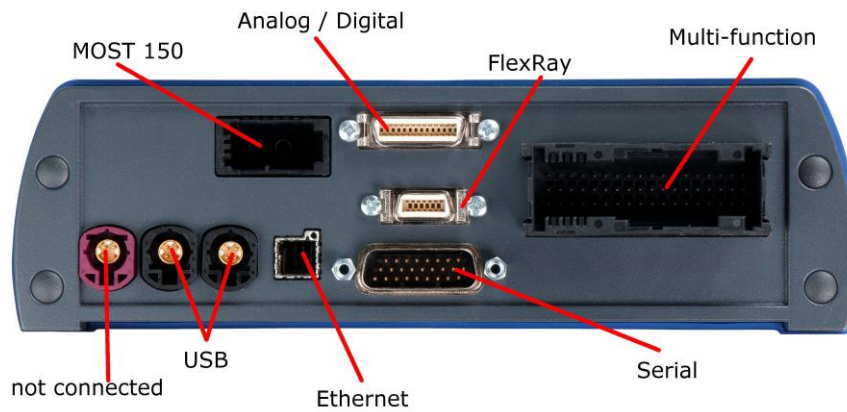

Figure 14.3: Rear side blue PiraT2_150M14C8LFR

14.1 Data logger: Multi function connector

Name	Type	Manufacturer-Nr.	Manufacturer
ELO 54pin	Shield	1-1355928-2	Tyco
	Housing	1355929-2	Tyco
	Housing	1355930-2	Tyco
	Contact	2-1411550-1	Tyco

Table 14.2: MQS 54pin

14.1.1 Pin assignment of the blue PiraT2 multi-function connector

@ Logger		comment / depiction / signal name	@ Vehicle Interface	
MQS 54pin	Signal		Type	Pin
1	KL15_Wake	Wakeup from KL 15	banana plug blue	----
2	HSCAN_L_11	High Speed CAN #11 LOW	DSUB-9 / male	2
3	HSCAN_L_10	High Speed CAN #10 LOW	DSUB-9 / male	2
4	HSCAN_L_9	High Speed CAN #09 LOW	DSUB-9 / male	2
5	HSCAN_L_8	High Speed CAN #08 LOW	DSUB-9 / male	2
6	HSCAN_L_7	High Speed CAN #07 LOW	DSUB-9 / male	2
7	HSCAN_L_6	High Speed CAN #06 LOW	DSUB-9 / male	2
8	HSCAN_L_5	High Speed CAN #05 LOW	DSUB-9 / male	2
9	HSCAN_L_4	High Speed CAN #04 LOW	DSUB-9 / male	2
10	HSCAN_L_3	High Speed CAN #03 LOW	DSUB-9 / male	2
11	HSCAN_L_2	High Speed CAN #02 LOW	DSUB-9 / male	2
12	HSCAN_L_1	High Speed CAN #01 LOW	DSUB-9 / male	2
13	LSCAN_L_1	Low Speed CAN #13 LOW	DSUB-9 / male	2
14	LIN_CON_7	LIN #7	DSUB-9 / male	7
15	TOUT_BAT	NA (rfu)	open	----
16	NA	Not connected	-----	----
17	NA	Not connected	-----	----
18	DIG_OUT_1	Digital OUT #01	banana jack green	----
19	HSCAN_H_12	High Speed CAN #12 HIGH	DSUB-9 / male	7
20	HSCAN_H_11	High Speed CAN #11 HIGH	DSUB-9 / male	7
21	HSCAN_H_10	High Speed CAN #10 HIGH	DSUB-9 / male	7
22	HSCAN_H_9	High Speed CAN #09 HIGH	DSUB-9 / male	7
23	HSCAN_H_8	High Speed CAN #08 HIGH	DSUB-9 / male	7
24	HSCAN_H_7	High Speed CAN #07 HIGH	DSUB-9 / male	7
25	HSCAN_H_6	High Speed CAN #06 HIGH	DSUB-9 / male	7
26	HSCAN_H_5	High Speed CAN #05 HIGH	DSUB-9 / male	7
27	HSCAN_H_4	High Speed CAN #04 HIGH	DSUB-9 / male	7
28	HSCAN_H_3	High Speed CAN #03 HIGH	DSUB-9 / male	7
29	HSCAN_H_2	High Speed CAN #02 HIGH	DSUB-9 / male	7
30	HSCAN_H_1	High Speed CAN #01 HIGH	DSUB-9 / male	7
31	LSCAN_H_1	Low Speed CAN #13 HIGH	DSUB-9 / male	7
32	LIN_CON_8	LIN #08	DSUB-9 / male	7
33	RIN_BAT	NA (rfu)	open	----
34	NA	Not connected (rfu)	-----	----
35	KL 30	Please combine pins 35, 37, 39 for the KL 30	banana plug red	----
36	NA	Not connected (rfu)	-----	----

37	KL 30	Please combine pins 35, 37, 39 for the KL 30	banana plug red	----
38	HSCAN_L_12	High Speed CAN #12 LOW	DSUB-9 / male	2
39	KL 30	Please combine pins 35, 37, 39 for the KL 30	banana plug red	----
40	TT_OUT_CON	Clock_Out for cascading device	Lumberg KV81-8	4
41	TT_IN_CON	Clock_In for cascading device	Lumberg KV81-8	5
42	LIN_CON_1	LIN #01	DSUB-9 / male	7
43	LIN_CON_2	LIN #02	DSUB-9 / male	7
44	LIN_CON_3	LIN #03	DSUB-9 / male	7
45	LSCAN_L_2	Low Speed CAN #14 LOW	DSUB-9 / male	2
46	LSCAN_H_2	Low Speed CAN #14 HIGH	DSUB-9 / male	7
47	LIN_CON_4	LIN #04	DSUB-9 / male	7
48	LIN_CON_5	LIN #05	DSUB-9 / male	7
49	LIN_CON_6	LIN #06	DSUB-9 / male	7
50	LSCAN_L_RC	CAN RemoteControl	LUMBERG KV81-8	1
51	LSCAN_H_RC	CAN RemoteControl	LUMBERG KV81-8	3
52	KL 31	Please combine pins 52, 53, 54 for the KL 31	banana plug black	----
53	KL 31	Please combine pins 52, 53, 54 for the KL 31	banana plug black	----
54	KL 31	Please combine pins 52, 53, 54 for the KL 31	banana plug black	----

Table 14.3: Pin assignment of the blue PiraT2 multi-function connector

14.1.2 Pin assignment of the blue PiraT2 5E multi-function connector

@ Logger		comment / depiction / signal name	@ Vehicle Interface	
MQS 54pin	Signal		Type	Pin
1	KL15_Wake	Wakeup from KL 15	banana plug blue	----
2	HSCAN_L_11	High Speed CAN #11 LOW	DSUB-9 / male	2
3	HSCAN_L_10	High Speed CAN #10 LOW	DSUB-9 / male	2
4	HSCAN_L_9	High Speed CAN #09 LOW	DSUB-9 / male	2
5	HSCAN_L_8	High Speed CAN #08 LOW	DSUB-9 / male	2
6	HSCAN_L_7	High Speed CAN #07 LOW	DSUB-9 / male	2
7	HSCAN_L_6	High Speed CAN #06 LOW	DSUB-9 / male	2
8	HSCAN_L_5	High Speed CAN #05 LOW	DSUB-9 / male	2
9	HSCAN_L_4	High Speed CAN #04 LOW	DSUB-9 / male	2
10	HSCAN_L_3	High Speed CAN #03 LOW	DSUB-9 / male	2
11	HSCAN_L_2	High Speed CAN #02 LOW	DSUB-9 / male	2
12	HSCAN_L_1	High Speed CAN #01 LOW	DSUB-9 / male	2
13	LSCAN_L_1	Low Speed CAN #13 LOW	DSUB-9 / male	2
14	LIN_CON_7	LIN #7	DSUB-9 / male	7
15	TOUT_BAT	NA (rfu)	open	----
16	NA	Not connected	-----	----
17	NA	Not connected	-----	----
18	DIG_OUT_1	Digital OUT #01	banana jack green	----
19	HSCAN_H_12	High Speed CAN #12 HIGH	DSUB-9 / male	7
20	HSCAN_H_11	High Speed CAN #11 HIGH	DSUB-9 / male	7
21	HSCAN_H_10	High Speed CAN #10 HIGH	DSUB-9 / male	7
22	HSCAN_H_9	High Speed CAN #09 HIGH	DSUB-9 / male	7
23	HSCAN_H_8	High Speed CAN #08 HIGH	DSUB-9 / male	7
24	HSCAN_H_7	High Speed CAN #07 HIGH	DSUB-9 / male	7
25	HSCAN_H_6	High Speed CAN #06 HIGH	DSUB-9 / male	7
26	HSCAN_H_5	High Speed CAN #05 HIGH	DSUB-9 / male	7
27	HSCAN_H_4	High Speed CAN #04 HIGH	DSUB-9 / male	7
28	HSCAN_H_3	High Speed CAN #03 HIGH	DSUB-9 / male	7
29	HSCAN_H_2	High Speed CAN #02 HIGH	DSUB-9 / male	7
30	HSCAN_H_1	High Speed CAN #01 HIGH	DSUB-9 / male	7
31	LSCAN_H_1	Low Speed CAN #13 HIGH	DSUB-9 / male	7
32	LIN_CON_8	LIN #08	DSUB-9 / male	7
33	RIN_BAT	NA (rfu)	open	----
34	NA	Not connected (rfu)	-----	----
35	NA	Not connected (rfu)	-----	----
36	NA	Not connected (rfu)	-----	----
37	NA	Not connected (rfu)	-----	----
38	HSCAN_L_12	High Speed CAN #12 LOW	DSUB-9 / male	2
39	NA	Not connected (rfu)	-----	----
40	TT_OUT_CON	Clock_Out for cascading device	Lumberg KV81-8	4
41	TT_IN_CON	Clock_In for cascading device	Lumberg KV81-8	5
42	LIN_CON_1	LIN #01	DSUB-9 / male	7
43	LIN_CON_2	LIN #02	DSUB-9 / male	7
44	LIN_CON_3	LIN #03	DSUB-9 / male	7
45	LSCAN_L_2	Low Speed CAN #14 LOW	DSUB-9 / male	2

46	LSCAN_H_2	Low Speed CAN #14 HIGH	DSUB-9 / male	7
47	LIN_CON_4	LIN #04	DSUB-9 / male	7
48	LIN_CON_5	LIN #05	DSUB-9 / male	7
49	LIN_CON_6	LIN #06	DSUB-9 / male	7
50	LSCAN_L_RC	CAN RemoteControl	LUMBERG KV81-8	1
51	LSCAN_H_RC	CAN RemoteControl	LUMBERG KV81-8	3
52	NA	Not connected (rfu)	-----	----
53	NA	Not connected (rfu)	-----	----
54	NA	Not connected (rfu)	-----	----

Table 14.4: Pin assignment of the blue PiraT2 5E multi-function connector
[Index](#)

14.2 blue PiraT2 5E – power harness

Name	Type	Manufacturer-Nr.	Manufacturer
SUB-D 3pol male	Connector	303W3CSXX43A10X	CONEC
	Housing	10070163-01LF	FCI

Table 14.5: blue PiraT2 5E – power harness

@ Logger		comment / depiction / signal name	@ Vehicle Interface	
SUB-D 3-pol	Signal		Type	Pin
A1	KL 31	KL 31 power supply (-)	banana plug black	1
A2	NA	Not connected		
A3	KL 30	KL 30 power supply (+) 15A fused	banana plug red	1

Table 14.6: Pin assignment of the blue PiraT2 5E – power harness

[Index](#)

14.3 Serial connector (D-Sub 26)

The 26-pin-D-Sub-connector combines RS232 digital and analog interfaces.

Name	Type	Manufacturer-Nr.	Manufacturer
DSUB 26pin	Connector	HD 26F	(Reichelt)
	Shell	1-1478762-5	Tyco

Table 14.7: D-Sub 26pin

@ Logger		comment / depiction / signal name	@ Vehicle Interface	
D-SUB 26pin	Signal		Type	Pin
1	RS232_TOUT_1	RS232 #1 Tx	DSUB-9 / male	3
2	RS232_ROUT_1	RS232 #1 Rx	DSUB-9 / male	2
3	RS232_TOUT_2	RS232 #2 Tx	DSUB-9 / male	3
4	RS232_ROUT_2	RS232 #2 Rx	DSUB-9 / male	2
5	NA	Not connected	-----	----
6	NA	Not connected	-----	----
7	NA	Not connected	-----	----
8	NA	Not connected	-----	----
9	NA	Not connected	-----	----
10	RS232_TOUT_3	RS232 #3 Tx	DSUB-9 / male	3
11	RS232_ROUT_3	RS232 #3 Rx	DSUB-9 / male	2
12	RS232_TOUT_4	RS232 #4 Tx	DSUB-9 / male	3
13	RS232_ROUT_4	RS232 #4 Rx	DSUB-9 / male	2
14	NA	Not connected	-----	----
15	NA	Not connected	-----	----
16	TT_CASCADE_CON	NA (rfu)	-----	----
17	NA	Not connected	-----	----
18	ANA_IN_GND_2	Please connect ANA_IN_GND_2 to KL 31	banana plug yellow	----
19	RS232_TOUT_5	RS232 #5 Tx	DSUB-9 / male	3
20	RS232_ROUT_5	RS232 #5 Rx	DSUB-9 / male	2
21	RS232_TOUT_6	RS232 #6 Tx	DSUB-9 / male	3
22	RS232_ROUT_6	RS232 #6 Rx	DSUB-9 / male	2
23	SYNC_CASCADE_CON	NA (rfu)	-----	----
24	DIG_IN_1	Digital IN #01 is referenced to KL 31 with internal Pull down, Threshold $9,2 \pm 0,1$ Volts, Hysteresis $0,4 \pm 0,1$ Volt DIG_IN_1 might be used as a Marker (with a push-button to positive Supply Voltage KL 30)	banana jack green	----
25	NA	Not connected	-----	----
26	ANA_INSGNL_2	Analog Interface #02 SIGNAL IN	banana plug yellow	----

Table 14.8: Pin assignment of the Digital/Analog connector

[Index](#)

14.4 Analog/Digital connector (26-pin) (not at 14C6S8L)

Name	Type	Manufacturer-Nr.	Manufacturer
Ribbon 26pin	Plug Connector	10126-3000PE	3M
	Shell	10326-52F0-008	3M

Table 14.9: Mini D Ribbon 3M 26pin

@ Logger		comment / depiction / signal name	@ Vehicle Interface	
3M 26pin	Signal		Type	Pin
1	DIG_IN_2	Digital IN #02 (Referenced to KL 31)	banana plug green	----
2	DIG_IN_3	Digital IN #03 (Referenced to KL 31)	banana plug green	----
3	DIG_IN_4	Digital IN #04 (Referenced to KL 31)	banana plug green	----
4	DIG_IN_5	Digital IN #05 (Referenced to KL 31)	banana plug green	----
5	DIG_OUT_2	Digital OUT #02	banana jack green	----
6	DIG_OUT_3	Digital OUT #03	banana jack green	----
7	SHIELD	NA	-----	----
8	SHIELD	NA	-----	----
9	ANA_IN_SGNL_3	Analog Interface #03 SIGNAL IN	banana plug yellow	----
10	ANA_IN_SGNL_4	Analog Interface #04 SIGNAL IN	banana plug yellow	----
11	ANA_IN_SGNL_5	Analog Interface #05 SIGNAL IN	banana plug yellow	----
12	ANA_IN_SGNL_6	Analog Interface #06 SIGNAL IN	banana plug yellow	----
13	ANA_IN_SGNL_7	Analog Interface #07 SIGNAL IN	banana plug yellow	----
14	ANA_IN_SGNL_8	Analog Interface #08 SIGNAL IN	banana plug yellow	----
15	ANA_IN_SGNL_9	Analog Interface #09 SIGNAL IN	banana plug yellow	----
16	ANA_IN_SGNL_10	Analog Interface #10 SIGNAL IN	banana plug yellow	----
17	ANA_IN_GND_3	Analog Interface #03 GROUND	banana plug yellow	----
18	ANA_IN_GND_4	Analog Interface #04 GROUND	banana plug yellow	----
19	ANA_IN_GND_5	Analog Interface #05 GROUND	banana plug yellow	----
20	ANA_IN_GND_6	Analog Interface #06 GROUND	banana plug yellow	----
21	ANA_IN_GND_7	Analog Interface #07 GROUND	banana plug yellow	----
22	ANA_IN_GND_8	Analog Interface #08 GROUND	banana plug yellow	----
23	ANA_IN_GND_9	Analog Interface #09 GROUND	banana plug yellow	----
24	ANA_IN_GND_10	Analog Interface #10 GROUND	banana plug yellow	----
25	SHIELD	NA	-----	----
26	ECL_IN	Electrical Control Line (SMSC)	DSUB-9 / male	7

Table 14.10: Pin assignment of the Analog/Digital connector

[Index](#)

14.5 Ethernet connector

Name	Type	Manufacturer-Nr.	Manufacturer
FCI	Cable Assembly	10054999-R0050Aulf	FCI

Table 14.11: FCI-Connector (Cable assembly 50 cm)

@ Logger		comment / depiction / signal name	@ Vehicle Interface	
3M 26pin	Signal		Type	Pin
A1	TX-	ETH1 Tx-	RJ45	2
B1	Tx+	ETH1 Tx+	RJ45	1
C1	GND			----
D1	RX+	ETH1 Rx+	RJ45	3
E1	RX-	ETH1 RX-	RJ45	6
A2	TX-	ETH2 Tx-	RJ45	2
B2	Tx+	ETH2 Tx+	RJ45	1
C2	GND			----
D2	RX+	ETH2 Rx+	RJ45	3
E2	RX-	ETH2 RX-	RJ45	6
A3	TX-	ETH3 Tx-	RJ45	2
B3	Tx+	ETH3 Tx+	RJ45	1
C3	GND			----
D3	RX+	ETH3 Rx+	RJ45	3
E3	RX-	ETH3 RX-	RJ45	6
A4	TX-	ETH4 Tx-	RJ45	2
B4	Tx+	ETH4 Tx+	RJ45	1
C4	GND			----
D4	RX+	ETH4 Rx+	RJ45	3

Table 14.12: Pin assignment of the Ethernet connector

[Index](#)

14.6 FlexRay connector

Name	Type	Manufacturer-Nr.	Manufacturer
Ribbon 14pin	Plug Connector	10114-3000PE	3M
	Shell	10314-52F0-008	3M

Table 14.13: Mini D Ribbon 3M 14pin

@ Logger		comment / depiction / signal name	@ Vehicle Interface	
3M 14pin	Signal		Type	Pin
1	FR_BP_1	FlexRay+ Channel 1a	DSUB-9 / male	7
2	NA	Not connected	-----	----
3	FR_BP_2	FlexRay+ Channel 1b	DSUB-9 / male	7
4	NA	Not connected	-----	----
5	FR_BM_2_2	FlexRay- Channel 2b	DSUB-9 / male	2
6	NA	Not connected	-----	----
7	FR_BM_2_1	FlexRay- Channel 2a	DSUB-9 / male	2
8	FR_BM_1	FlexRay- Channel 1a	DSUB-9 / male	2
9	NA	Not connected	-----	----
10	FR_BM_2	FlexRay- Channel 1b	DSUB-9 / male	2
11	NA	Not connected	-----	----
12	FR_BP_2_2	FlexRay+ Channel 2b	DSUB-9 / male	7
13	NA	Not connected	-----	----
14	FR_BP_2_1	FlexRay+ Channel 2a	DSUB-9 / male	7

Table 14.14: Pin assignment of the FlexRay connector

[Index](#)

14.7 CAN/FlexRay (D-Sub 44) (25M24C8LFR only)

Name	Type	Manufacturer-Nr.	Manufacturer
DSUB 44pin	Connector	17EHD-044-P-AA-0-00	Amphenol
	Shell	17E-1726-2	Amphenol

Table 14.15: D-SUB 44pin

@ Logger		comment / depiction / signal name	@ Vehicle Interface	
D-SUB 44pin	Signal		Type	Pin
1	HSCAN_L_15	High Speed CAN #15 LOW	DSUB-9 / male	2
2	HSCAN_L_16	High Speed CAN #16 LOW	DSUB-9 / male	2
3	HSCAN_L_17	High Speed CAN #17 LOW	DSUB-9 / male	2
4	HSCAN_L_18	High Speed CAN #18 LOW	DSUB-9 / male	2
5	HSCAN_L_19	High Speed CAN #19 LOW	DSUB-9 / male	2
6	HSCAN_L_20	High Speed CAN #20 LOW	DSUB-9 / male	2
7	HSCAN_L_21	High Speed CAN #21 LOW	DSUB-9 / male	2
8	HSCAN_L_22	High Speed CAN #22 LOW	DSUB-9 / male	2
9	HSCAN_L_23	High Speed CAN #23 LOW	DSUB-9 / male	2
10	HSCAN_L_24	High Speed CAN #24 LOW	DSUB-9 / male	2
11	NA	Not connected	-----	----
12	FR_BM_1	FlexRay- Channel 1a	DSUB-9 / male	2
13	FR_BM_2	FlexRay- Channel 1b	DSUB-9 / male	2
14	FR_BM_2_1	FlexRay- Channel 2a	DSUB-9 / male	2
15	FR_BM_2_2	FlexRay- Channel 2b	DSUB-9 / male	2
16	HSCAN_H_15	High Speed CAN #15 HIGH	DSUB-9 / male	7
17	HSCAN_H_16	High Speed CAN #16 HIGH	DSUB-9 / male	7
18	HSCAN_H_17	High Speed CAN #17 HIGH	DSUB-9 / male	7
19	HSCAN_H_18	High Speed CAN #18 HIGH	DSUB-9 / male	7
20	HSCAN_H_19	High Speed CAN #19 HIGH	DSUB-9 / male	7
21	HSCAN_H_20	High Speed CAN #20 HIGH	DSUB-9 / male	7
22	HSCAN_H_21	High Speed CAN #21 HIGH	DSUB-9 / male	7
23	HSCAN_H_22	High Speed CAN #22 HIGH	DSUB-9 / male	7
24	HSCAN_H_23	High Speed CAN #23 HIGH	DSUB-9 / male	7
25	HSCAN_H_24	High Speed CAN #24 HIGH	DSUB-9 / male	7
26	NA	Not connected	-----	----
27	FR_BP_1	FlexRay+ Channel 1a	DSUB-9 / male	7
28	FR_BP_2	FlexRay+ Channel 1b	DSUB-9 / male	7
29	FR_BP_2_1	FlexRay+ Channel 2a	DSUB-9 / male	7
30	FR_BP_2_2	FlexRay+ Channel 2b	DSUB-9 / male	7
31	NA	Not connected	-----	----
32	NA	Not connected	-----	----
33	NA	Not connected	-----	----
34	NA	Not connected	-----	----
35	NA	Not connected	-----	----
36	NA	Not connected	-----	----
37	NA	Not connected	-----	----
38	NA	Not connected	-----	----
39	NA	Not connected	-----	----

40	NA	Not connected	-----	----
41	NA	Not connected	-----	----
42	NA	Not connected	-----	----
43	NA	Not connected	-----	----
44	NA	Not connected	-----	----

Table 14.16: Pin assignment of the CAN/FlexRay connector

[Index](#)

14.7.1 Connection to Remote Control Voice

Connector KV81-8 for Remote Control / Remote Control Voice is connected to Pins 40, 41, 50, 51 of MQS54. Clamp 30 and clamp 31 are directly connected to the cable harness.

@ Logger		comment / depiction / signalname	@ Vehicle Interface	
MQS 54pin	Signal		Type	Pin
50	LSCAN_L_RC	CAN RemoteControl	Lumberg KV81-8	1
-----	NA	Not connected	Lumberg KV81-8	2
51	LSCAN_H_RC	CAN RemoteControl	Lumberg KV81-8	3
40	TT_OUT_CON	Clock_Out for cascading device	Lumberg KV81-8	4
41	TT_IN_CON	Clock_IN for cascading device	Lumberg KV81-8	5
-----	KL 31	KL 31	Lumberg KV81-8	6
-----	KL 30	KL 30	Lumberg KV81-8	7
-----	NA	Not connected	Lumberg KV81-8	8
-----	NA	Not connected	Lumberg KV81-8	9

Table 14.17: Contacts of the DIN plug

MQS 54pin	Lumberg KV81-8 Pin	Lemo Pin	Bananaplug Pin	Signal
40	4	-	-	TT_OUT_CON
41	5	-	-	TT_IN_CON
50	1	6	-	LSCAN_L_RC
51	3	3	-	LSCAN_H_RC
54 / 52 / 53	6	7	black	KL 31 (ground, -)
54 / 52 / 53	7	2	red	KL 31 (power,+)

Table 14.18: Contacts of the angeled Lemo plug

[Index](#)

14.7.2 Contacts of the Remote Control Voice cable

These two drawings show the pinout of the Remote Control Voice cable.

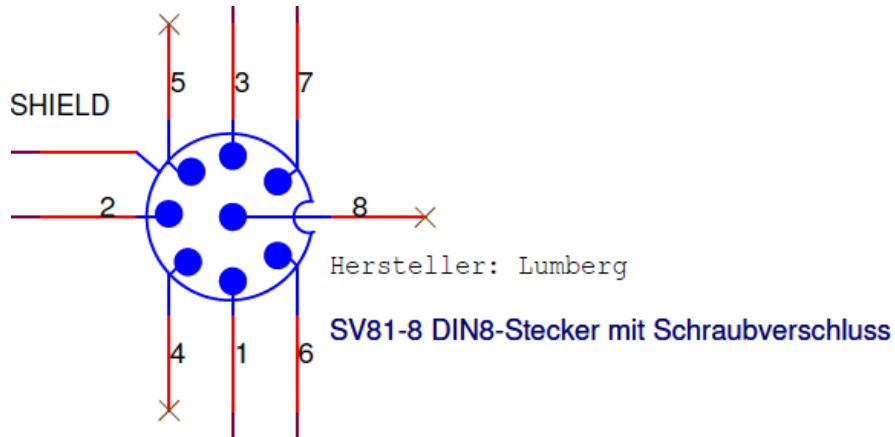

Figure 14.4: Pins des DIN-Steckers DIN-Steckers (Lumberg SV81-8 DIN8)

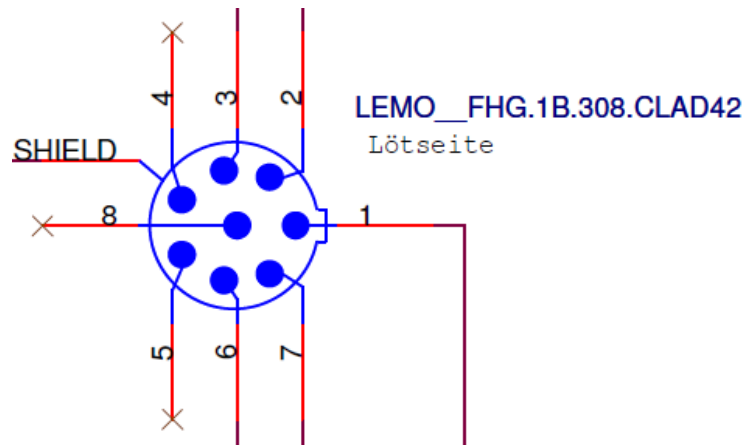

Figure 14.5: Pins des gewinkelten LEMO-Steckers (FGH.1B.308.CLAD42)

14.8 Pinning of the FCI connector for the Ethernet-Kit

RJ45-Jack Pin(Signal)	1 (Tx+)	2 (Tx-)	3 (Rx+)	4	5	6 (Rx-)	7	8
FCI-Jack Pin	B1	A1	D1			E1		
	B2	A2	D2			E2		
	B3	A3	D3			E3		
	B4	A4	D4			E4		

Table 14.19: Pinning of the FCI connector for the Ethernet-Kit

[Index](#)

15 Abbreviations

Kürzel / abbreviation	Bedeutung / meaning
blue PiraT	P rocessing I nformation R ecording A nalyzing T ool
bP	blue PiraT
bP2	blue PiraT2
bP2 5E	blue PiraT2 5E
bPMini	blue PiraT Mini
RC Touch	R emote C ontrol T ouch
bP Remote	blue PiraT Remote
A2L	A SAM M CD-2 M C L anguage
AE	A utomotive E lectronics
ACK	A C K nowledged
CAN	C ontroller A rea N etwork
CCP	C AN C alibration P rotocol
CF	C ompact F lash
CRO	C ommand R eceive O bject
DAQ	D ata A cquisition
DTO	D ata T ransmission O bject
ECL	E lectrical C ontrol L ine
ECU	E lectronic C ontrol U nit
FIBEX	F ield B us E xchange F ormat
FW	F irmware
GMT	G reenwich M ean T ime
INCA	I N T egrated C alibration and A pplication T ool
LAN	L ocal A rea N etwork = Netzwerk
LIN	L ocal I nterconnect N etwork
MAC	M edia A ccess C ontrol
MCD	M easure C alibrate D iagnose
MDX	M eta D ata E Xchange F ormat
MEP	M OST E thernet P acket
MOST	M edia O riented S ystems T ransport (www.mostnet.de)
ODT	O bject D escriptor T able
ODX	O pen D ata E Xchange
OEM	O riginal E quipment M anufacturer

PHY	PHY sical Bus Connect
PW	Pass wort
RX	Re ceiver Data
SD	Secure Digital
SFTP	Secure File Transfer Protocol
SHA	Secure Hash
SSL	Secure Sockets Layer
TCP/IP	Transmission Control Protocol/ Internet Protocol
TLS	Transport Layer Security
TMP	Telemotive Packetformat
TSL	Telemotive System Link
UDP	User Datagram Protocol
USB	Universal Serial Bus
UTC	Universal Time, Coordinated
Wi-Fi	Wireless Fidelity
WLAN	Wireless Local Area Network
XCP	Universal Measurement and Calibration Protocol

Table 15.1: Abbreviations
[Index](#)

16 List of figures

Figure 4.1: links to the manuals	8
Figure 5.1: Interface (overview)	10
Figure 6.1: Front side of the blue PiraT2	12
Figure 6.2: Front side of the blue PiraT2 5E	12
Figure 7.1: Power connection of the blue PiraT2	21
Figure 7.2: Power connection of the blue PiraT2 5E	21
Figure 7.3: Switching on	21
Figure 7.4: Info screen IP address.....	22
Figure 7.5: Telemotive Client Portal.....	23
Figure 7.6: Desktop icon.....	24
Figure 7.7: links to the manuals	24
Figure 7.8: Rear side of the blue PiraT2 with MOST150.....	25
Figure 7.9: Rear side of the data logger blue PiraT2 5E MOST150	26
Figure 7.10: new power supply connector with reverse polarity protection.....	26
Figure 8.1: Connecting the blue PiraT2 via the universal adapter cable	27
Figure 8.2: Power cable for blue PiraT2 5E	27
Figure 8.3: RS232/digital/analog adapter cable	28
Figure 8.4: Listening to a bidirectional serial communication	28
Figure 8.5: Adapter cables for digital/analog.....	29
Figure 8.6: Adapter cables for FlexRay	29
Figure 8.7: Adapter cables for CAN/FlexRay	29
Figure 8.8: Adapter cable for Remote Control Voice (RCV).....	30
Figure 8.9: Ethernet kit for blue PiraT2	30
Figure 9.1: Sampling interval.....	31
Figure 9.2: Setting triggers using digital Input.....	32
Figure 14.1: Rear side blue PiraT2_14C6S8L	53
Figure 14.2: Rear side blue PiraT2_25M24C8LFR	53
Figure 14.3: Rear side blue PiraT2_150M14C8LFR	53
Figure 14.4: Pins des DIN-Steckers DIN-Steckers (Lumberg SV81-8 DIN8).....	66
Figure 14.5: Pins des gewinkelten LEMO-Steckers (FGH.1B.308.CLAD42).....	66

[Index](#)

17 List of tables

Table 4.1: Additional features by optional licenses	9
Table 5.1: Model versions of blue PiraT2 / blue PiraT2 5E	11
Table 6.1: LED behavior	14
Table 6.2: Interface abbreviations and status information	16
Table 9.1: Accuracy of marker	32
Table 9.2: Standby mode – [W= wake up A= keep alive]	33
Table 9.3: Status Logger: OK	34
Table 9.4: Status Logger: RING	35
Table 9.5: Status Logger: MEM	35
Table 9.6: Status Logger: Memory Full	36
Table 9.7: Status Logger: ERROR	36
Table 10.1: CAN	37
Table 10.2: LIN	39
Table 10.3: Serial interface	40
Table 10.4: FlexRay	40
Table 10.5: MOST25 data logging	43
Table 10.6: MOST150 data logging	43
Table 11.1: Conversion options (overview)	45
Table 13.1: Datasheet	51
Table 14.1: Extension harness (overview)	52
Table 14.2: MQS 54pin	54
Table 14.3: Pin assignment of the blue PiraT2 multi-function connector	55
Table 14.4: Pin assignment of the blue PiraT2 5E multi-function connector	57
Table 14.5: blue PiraT2 5E – power harness	58
Table 14.6: Pin assignment of the blue PiraT2 5E – power harness	58
Table 14.7: D-Sub 26pin	59
Table 14.8: Pin assignment of the Digital/Analog connector	59
Table 14.9: Mini D Ribbon 3M 26pin	60
Table 14.10: Pin assignment of the Analog/Digital connector	60
Table 14.11: FCI-Connector (Cable assembly 50 cm)	61
Table 14.12: Pin assignment of the Ethernet connector	61
Table 14.13: Mini D Ribbon 3M 14pin	62
Table 14.14: Pin assignment of the FlexRay connector	62
Table 14.15: D-SUB 44pin	63
Table 14.16: Pin assignment of the CAN/FlexRay connector	64
Table 14.17: Contacts of the DIN plug	65
Table 14.18: Contacts of the angeled Lemo plug	65
Table 14.19: Pinning of the FCI connector for the Ethernet-Kit	66
Table 15.1: Abbreviations	68

[Index](#)

18 Contact



Telemotive AG

Office München
Frankfurter Ring 115a
80807 München

Tel.: +49 89 357186-0
Fax.: +49 89 357186-520
E-Mail: info@telemotive.de
Web: www.telemotive.de

Sales
Tel.: +49 89 357186-550
Fax.: +49 89 357186-520
E-Mail: sales@telemotive.de

Support
Tel.: +49 89 357186-518
E-Mail: productsupport@telemotive.de
ServiceCenter: <https://sc.telemotive.de/bluepirat>